

CORNET: IN2EUROBUILD –

CONSISTENT EUROPEAN GUIDELINES FOR INTERNAL INSULATION OF BUILDING STOCK AND HERITAGE

Guideline part 2:

Façade Renovation and Interior Insulation

Project number:

247 EBG

Project duration:

01.05.2019 until 31.12.2021



Dresden University of Technology
Institute for Building Climatology (IBK)



Fraunhofer Institute for Building Physics
(IBP) Holzkirchen



Buildwise Belgium



Institute for Wood Technology Dresden (IHD)

30. November 2022

CORNET: IN2EUROBUILD

Consistent European Guidelines for Internal Insulation of Building Stock and Heritage

Guideline part 2: Façade Renovation and Interior Insulation

The CORNET/IGF project 247 EBG IN2EuroBuild of the research association Trägerverein Institut für Holztechnologie Dresden e.V. (TIHD) was funded by the Federal Ministry of Economics and Climate Protection via the AiF within the framework of the programme for the promotion of joint industrial research (IGF) on the basis of a resolution of the German Bundestag and by the Department of 'Research and Technological Development' ('Recherche et Développement Technologique') of the Walloon Public Service 'Economy, Employment and Research' (Service Public de Wallonie 'Économie, Emploi, Recherche').

Authors: Heike Sonntag
Ulrich Ruisinger
Christian Conrad
Eri Tanaka
Tobias Schöner
Daniel Zirkelbach
Timo De Mets
Yves Vanhellemont

Technische Universität Dresden

Institut für Bauklimatik
D - 01069 Dresden
Telefon: +49 (0)351 463-35259
Telefax: +49 (0)351 463-32627
www.tu-dresden.de/bu/architektur/ibk

Fraunhofer Institut für Bauphysik

Fraunhoferstraße 10
D - 83626 Valley
Telefon: +49 (0)8024 643-0
Telefax: +49 (0)8024 643-366
www.ibp.fraunhofer.de

Buildwise (previously Belgian Building Research Institute)

Avenue Pierre Holoffe 21
B - 1342 Limelette
Telefon: +32 (0)2 655-0
Telefax: +32 (0)2 653-0729
www.buildwise.be (previously www.bbri.be)

Dresden, Holzkirchen, Limelette, 30.11.2022

Content

1	Introduction.....	1
2	Planning phases.....	2
3	Façade renovation concept.....	5
3.1	Monument status	5
3.2	Documentation of the condition of the façade	5
3.3	General measures on the existing structure	6
3.4	Notes on driving rain / splash water protection	10
3.5	Measures for plaster facades	15
3.6	Measures for exposed masonry.....	16
4	Development of an insulation concept	19
4.1	Determination of desired insulation standard.....	19
4.2	Selection of possible insulation systems.....	20
4.3	Overview of the most important evaluation criteria	28
4.4	Hygrothermal behaviour of typical insulation systems.....	28
5	Dimensioning and verification.....	29
5.1	Verification free / deemed to satisfy interior insulations according to DIN 4108-3	30
5.2	Simplified verification for internal insulation	30
5.3	Extension of the simplified verification – classification of vapour permeable,..... capillary-active insulation systems.....	31
5.4	Verification by hygrothermal simulation.....	34
5.5	Simulation tables for typical applications / approvals by manufactures.....	36
6	Dimensioning / execution of connection details.....	37
6.1	General dimensioning recommendations	37
6.2	Typical connection details	39
6.3	Selection criteria for the detailed design	40
6.4	Constructive tips for interior insulation measures	43
6.5	Hygrothermal simulation of connection details.....	46
7	Literature	47
A	Appendix.....	49
A I	Description of waterproofing systems	49
A II	Insulation systems investigated for hygrothermal behaviour (from EnEffID).....	53
A III	Preparation of a simplified verification according to WTA guideline 6-4.....	57
A IV	Boundary conditions for the simplified verification for the classification	
	of vapour permeable, capillary-active insulation materials	58

Table of contents

A V	Evaluation of the classification of vapour permeable, capillary-active insulation materials.....	59
A VI	Characteristic values, boundary conditions and evaluation criteria for hygrothermal simulations	60
A VII	Application example for a one-dimensional hygrothermal design	63
A VIII	Application examples for the hygrothermal design of connection details.....	67
A IX	Typical connection details	74
A X	Flowchart Facade renovation concept.....	101
A XI	Flowchart Insulation concept.....	102

1 Introduction

The consumption of heating energy in existing buildings represents a large share of total national energy consumption and therefore contributes significantly to the production of climate-damaging CO₂. In order to stop climate change and make a substantial contribution to climate protection, heating energy consumption must therefore be reduced urgently. The most effective way to do this is to maintain and renovate uninsulated buildings.

Thermal insulation is and remains one of the most important measures for reducing energy demand in buildings. Interior insulation has become increasingly important in recent years. This is due to the fact that a considerable part of the building stock, which can easily be insulated from the outside, has already been renovated. On the other hand, the proportion of remaining buildings where, for various reasons, only interior insulation is possible or even more advantageous, is becoming larger and larger.

The surface area of the exterior walls accounts for a large proportion of the total building and thus of the potential for energy optimisation. In order to achieve optimal renovation success, the presented concept is developed on the basis of the existing condition of the building.

The first part of the two guidelines therefore deals with the assessment and condition analysis of buildings. This second part describes the preparation of a renovation concept and also provides information on what must be taken into account in the planning, dimensioning and implementation of an internal insulation measure.

In some old buildings, interior insulation is the only option for insulating the exterior walls. This is particularly the case when facades that are characteristic of the cityscape, valuable in terms of architectural culture or otherwise worthy of preservation are the subject of energy retrofitting, as well as in the case of unrendered masonry or border buildings. This possibility of energy upgrading is also used for properties with inconsistent ownership and in cases where insulation on the outside is economically less favourable. However, in buildings that are only used temporarily, interior insulation can also have significant energy advantages, as it enables significantly faster and cheaper heating up. In general, it should be noted that interior insulation can sometimes significantly change the temperature and humidity conditions within the wall construction, as the existing wall becomes significantly colder, especially during the heating period. In addition to the energy-related aspects, the moisture-related aspects are therefore of particular importance.

In the meantime, there are many system solutions for interior insulation with proven implementation details and decades of positive experience. For example, there are systems that have been known for a long time that limit the transport of water vapour through the exterior wall by means of vapour-barrier layers. Furthermore, systems have been developed that are open to diffusion, but counteract the increase in moisture on the cold side of the insulation through other properties, such as capillary transport and moisture storage. These systems can no longer be proven with the *Glaser* method, a hand calculation method, which is well known among planners. One of the reasons for this is that this method only takes into account water vapour transport as a mechanism of moisture transfer. Liquid water transport through the building component, for example as a result of condensation formation or rainwater absorption and moisture storage, is not taken into account.

For some planners, there is a certain uncertainty in the application due to the multitude of available systems and modes of action. This current guide is intended to provide support in the planning process and contribute to the decision-making process.

The two guidelines were developed on the basis of earlier research projects by the Fraunhofer Institute for Building Physics (IBP), the Institute for Building Climatology at the Technical University of Dresden (IBK) and Buildwise (Belgium). From the supplementary investigations in the joint project In2EuroBuild, the present guidebook provides the following information in relation to the planning of new projects with internal insulation

- advice is given on the necessary preliminary investigations,
- procedures for damage-free execution explained,
- areas of application and limits of interior insulation are shown and
- criteria for selecting the appropriate insulation systems.

This guide is intended as a consolidation and summary of the already existing specialist compendia, e. g. [1], [2] and [3] as well as individual guidelines, e. g. WTA-guideline 6-4-16 [4] and assists from the analysis of the existing situation to the planning and selection of suitable systems right up to the concrete implementation.

NOTE: At the end of this guide there are two flowcharts that illustrate the preparation of a façade renovation concept and of an internal insulation concept. Use the buttons in the text to open the appropriate section of the flowchart. Corresponding buttons in the flowchart lead back again.

2 Planning phases

The planning of interior insulation takes place in three phases. It begins with a stocktaking to record the relevant information and the structural condition of the building, including characteristic values of building physics. This topic is covered in Part 1 of the guide (Building Analysis).

Once the condition of the building has been adequately recorded and the causes of any existing damage have been identified, the renovation concept can be drawn up on this basis, starting with the façade renovation concept.

Subsequently, a concrete insulation system can be defined and verified against the background of damage prevention, reduction of heating energy losses, cost specifications, monument preservation requirements as well as design and construction requirements.

The last step is the selection of the relevant, i.e. representative connection details and their dimensioning.

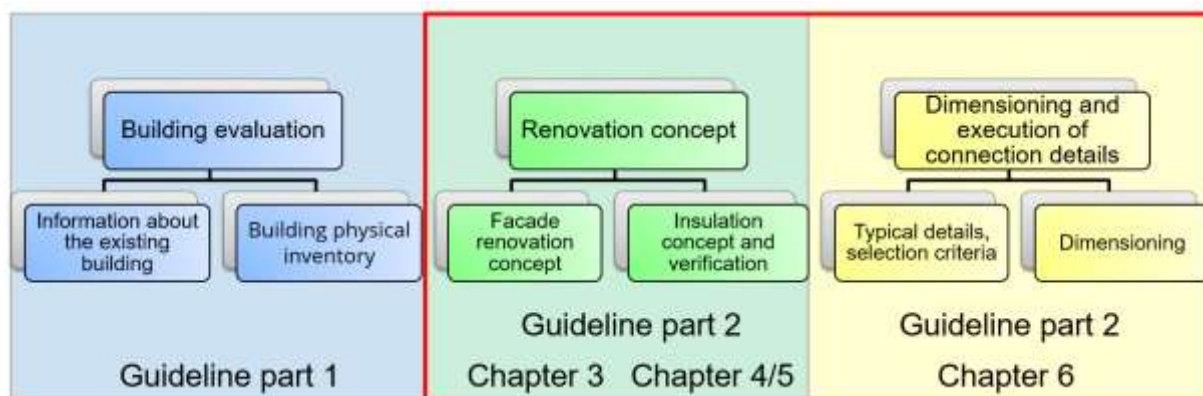

Fig. 1 Phases in the planning of interior insulation systems

Working through the individual phases and work steps in the order shown in the diagram (from left to right) has proven useful in practice, as important interdependencies must be taken into account.

For a better overview, the scope of the as-built analysis was summarised as a separate part 1 of the guide. The renovation concept and the dimensioning of structural connection details have been summarised as a planning guide in this Part 2.

To ensure that all trades run as smoothly as possible and to avoid needless delays, necessary preliminary work and required technological times must be included in the planning. In addition, a sensible sequence of the trades must be taken into account.

Safeguarding measures, removal of moisture sources

The first step is to carry out the necessary securing measures on the building, if required, and to introduce measures to protect against further moisture impact. Please refer to chapter 3.3.1 for more information.

Removal of moisture damage, drying of building components

Prior to the implementation of an energy retrofit measure, the effort for the elimination of moisture damage and necessary component drying must be planned into the time schedule as early as possible after the securing and provisional protective measures. Depending on the condition of the existing structure, the drying services can be very time-consuming. However, they are essential for sustainable restoration success. In this context, it is important to observe the chapters 3.3.2 and 3.3.3.

Sealing measures

After drying the existing structure (or the areas to be sealed), the waterproofing work is carried out. Here, the planned waterproofing levels are to be installed for the respective specified design case or according to the developed waterproofing concept (e.g. horizontal waterproofing in wall constructions and on the floor, vertical waterproofing in the area in contact with the ground). It should be noted that after a waterproofing measure, the remaining drying potential is small.

Preparing the driving rain protection

If the as-built investigations have shown that the façade is not (sufficiently) protected against driving rain and action is required, the (re-)installation of driving rain protection is initiated (after drying and if necessary). Suitable measures are described in the chapter 3.4.

Base preparation for interior insulation system

Only after the measures to prevent further moisture penetration have been carried out (depending on the necessity) and sufficient drying of moist wall areas has taken place, the interior insulation system can be applied. Further preliminary work might be necessary for this.

As a rule, the substrate of the existing wall must be clean, load-bearing and dry. Non-load-bearing undercoat plaster, gypsum components, barrier layers, paints and wallpapers must be removed. The necessary preparatory work also depends on the insulation system used (manufacturer's instructions).

If board-type interior insulation materials are to be applied, a level surface is required. Depending on the condition of the existing surface, it is therefore necessary to apply a base coat, especially when using a capillary-active, diffusion-open interior insulation.

The following properties are recommended for a newly applied base render when planning a diffusion-open, capillary-active insulation system:

- compressive strength: 3-5 N/mm²
- high porosity
- vapour diffusion resistance $\mu \leq 15$
- sufficient capillary activity ($A_w > 1 \text{ kg}/(\text{m}^2 \cdot \text{h}^{0,5})$)

Here, the necessary drying times of the base plaster must be observed until the interior insulation can be applied. NHL plasters, lime plasters with low cement content or special base plasters are often used.

With malleable insulation materials such as insulating plasters and spray-on cellulose or backfill mortar in cavity walls, no base coat is required.

Applying the interior insulation system

The individual components of interior insulation systems are matched to each other, which is why only components that belong to the system may be used. If product systems are mixed, there is a risk that the wall will become moist. The insulation boards must be installed and processed according to the manufacturer's instructions.

When using thermal insulation plasters or cob insulation, the additional moisture input and the associated necessary drying time must be taken into account in the further process.

The installation of new windows or other building elements in the exterior wall should be done before the interior insulation is installed. The reveal and lintel insulation of the selected interior insulation system is then connected to the window element in an airtight manner and optimised for thermal bridges.

Floor construction, ceiling panelling

Further interior work, such as the construction of the floor structure and the installation of ceiling panelling or suspended ceilings, takes place after the installation of the interior insulation. This ensures that potential heat-conducting installations (such as screed) do not directly touch the cold existing wall, but the warmer surface of the interior insulation.

3 Façade renovation concept

Before a planned interior insulation measure, the condition of the building's façade must be examined more closely. The planned insulation tends to make the existing wall colder, which means that less drying potential is available than before the measure.

The protective function of a façade decreases over the years due to weathering and other influences, which becomes apparent through changes in strength, colour or material properties. Depending on the façade material and quality, appropriate maintenance cycles must therefore be planned.

The preparation of a façade renovation concept makes sense if the renovation effort cannot be readily estimated due to the complexity of the process. This applies, for example, to natural stone façades or unrendered façades where compliance with driving rain protection cannot be ensured. In addition, the preparation of a concept for façades with extensive, obvious damage, the comprehensive recording and assessment of which would go beyond the scope of an initial building/moisture condition survey, is recommended.

The measures recommended in the following aim, on the one hand, to obtain a driving rain-proof, stable façade and, on the other hand, to maintain or increase the drying potential of a façade.

3.1 Monument status

There are special challenges in renovation when the building to be renovated is a listed building. In this case, it is advisable to consult the monument protection authority of the respective state or federal province at an early stage. Structural changes must be coordinated with the authority. This may result in conflicting requirements and wishes, e.g. that the width of window elevations cannot be changed or that historically valuable façades may not be painted (and thus receive the necessary protection against driving rain) or that no changes are permitted to visible brick façades (e.g. metal sheet covering in the area of projections). Compromises must be found here in cooperation with the authorities. Requirements for the protection of historical monuments depend on the decisions of the respective authorities in individual cases and are not generally applicable.

The procedures and recommendations in this guide refer in each case to measures that make sense in terms of building physics - whether these are feasible in the context of monument protection must be clarified in each individual case.

3.2 Documentation of the condition of the façade

The basis for the construction schedule and for an exact calculation of the costs with the immanent dependencies is the documentation of the condition of the façade and the existing relevant defects.

For this purpose, the individual damages to the façade are mapped and classified in detail. Special construction features of the façade and their effects are presented.

The following damage can occur and should be recorded in the mapping:

- frost splitting
- salt loads
- damage to the façade material (stones, joints and plaster)
- cracks (e.g. constructional, underground-related, material-related)
- visible moisture penetrations and moisture horizons
- algae or mould formation
- fouling
- sources of moisture (defective building drainage outside/inside, splash water, damp rooms)

The following figure shows a building view as part of the documentation of the façade condition.



Fig. 2 Drawing with damage pattern found on a façade

3.3 General measures on the existing structure

3.3.1 Removal of moisture sources

The existing moisture loads and their causes were determined and quantified as part of the building condition analysis (Part 1 of the Guide).

In many projects (especially in buildings that have been vacant for a long time or have a renovation backlog), structural safety measures must first be carried out on the building or on endangered parts of the building for (temporary) preservation and to prevent further damage. This is usually necessary due to structural damage for static reasons or due to a lack of weather protection.

In the case of large defects in the roof structure or in the roof drainage, this means, for example, that provisional protective measures (covering with tarpaulins or emergency roof to prevent further water ingress, rain drainage away from the building) are provided. In most cases, this is already recognisable during the first building inspection, so that these indications are already communicated to the building owner as immediate measures in the building or moisture condition report.

Before carrying out an insulation measure, appropriate precautions must be taken to ensure that there is no problem with rising and laterally penetrating moisture from the ground/plinth area and that the façade construction is designed to be driving rain-proof.

For many types of damage, more extensive measures as well as combinations of measures are necessary to eliminate the moisture damage. In the appendix of Part 1 of the guide (inventory analysis), examples of typical damage patterns are presented, with causes and proposed solutions for remediation described.

3.3.2 Consideration of vapour tight coatings

When drawing up the concept, care should be taken to ensure that the greatest possible drying potential remains or can be produced towards the outside.

In the past, coatings and plasters were often used that are unsuitable for driving rain protection according to the current state of the art and in combination with interior insulation. Therefore, if there are surface layers that clearly inhibit the transport of water vapour, which reduce the drying of the masonry to the outside and thus have a particularly unfavourable effect when interior insulation is installed, consideration should be given to remove such layers. This is especially true if damage is already visible on the surface, such as cracks, frost damage and spalling.



Fig. 3 Example of dense coatings to be removed

Such layers can remain if:

- with these layers the façade is free of damage in the long term,
- they are on sides facing away from the weather,
- no permanent/long-term high moisture content is present,
- interior insulation of low thickness is used (proof-free constructions according to DIN 4108-3 [5])

Hygrothermal simulations or expert assessment can support the decision-making process as to whether removal of the layers is necessary or not. In individual cases, damage to the façade can occur if such layers are left in place, as the drying potential is further reduced by interior insulation.

- Stronger vapour retardant coatings should ideally be removed, either by chemical or mechanical means. Practice shows that removal is never completely possible and that the pores are still filled with paint residues on the surface. This should not be a problem with only partially vapour-barrier paints (such as acrylic paints), but can prove negative with more vapour-tight paints, such as oil paints, epoxy resin paints or similar coatings. In such cases, paint removal must be more invasive, inevitably damaging the surface of the masonry, so that it is often necessary to apply a new coating for better protection of the (now damaged) façade. These principles also apply to façades that have been coated with bituminous products.
- Cement-based plasters that are too vapour-tight or plasters with dense additives, which often show cracks, should be removed. Experience shows that the moisture that has penetrated through cracks and skips dries out again only very slowly, so that the masonry becomes more moist again over time. Removing such plasters often damages the adjacent masonry. Therefore, suitable coatings or (more vapour-permeable) plasters must often be applied to the damaged masonry afterwards.

3.3.3 Drying measures

With the planned installation of interior insulation, the drying capacity of the construction is reduced to a greater or lesser extent as a result of the colder existing exterior wall.

When planning the renovation, it is important to bear in mind that it can take a long time for the soaked walls to dry out. Particularly in the case of heavily soaked walls, the damaged interior plaster and dense layers (such as tiles), which will be replaced anyway as part of the construction work, should therefore be removed as early as possible in order to create sufficient time and drying potential towards the interior. When removing damaged exterior plaster, a temporary driving rain protection (e.g. by scaffolding) protects against renewed rain penetration into the façade.

It is most favourable if the building or the affected construction areas can dry with natural ventilation after the immediate measures have been carried out. Seasons in which the absolute moisture content (in g/m³ or g/kg) of the outdoor air is lower than in the indoor air are suitable for this. This is the case in the cold months. Through a controlled air exchange, cold, dry air is thus brought into the building and the warmer, moisture-loaded air is removed from the building. The summer months are only suitable to a very limited extent, especially for drying basement areas: in unfavourable conditions humidification can occur due to ventilation ("summer condensation").

Ventilation can also be controlled with simple fan units in combination with humidity sensors on the outside and inside, so that ventilation only takes place when the absolute humidity content outside is lower than inside.

By measuring the moisture again in selected areas (if necessary), it is then possible to check how successful the immediate weather protection measures and drying measures were. If this is not sufficient or takes too long, classical technical drying can be resorted to.

In the area of exterior walls in contact with the ground, where the horizontal barrier or vertical sealing is not intact, it is advisable to start the drying measure only during or after the exterior sealing measure, so that no moisture is drawn in from the ground.

Depending on the local and structural conditions as well as the drying behaviour of the affected building components, various established methods are available for drying exterior walls. Their application possibilities, limits and success monitoring describe the WTA-guideline 6-15-13 [6] and the WTA-guideline 6-16-19 [7]. In the case of technical drying measures, accompanying monitoring of the moisture development is recommended to ensure sustainable success. If drying (or heating) is carried out permanently or with too much energy, the wall surface will initially dry out considerably. However, in the deeper areas of the wall the moisture will remain. If the wall surface is very dry, the moisture from the deeper wall layers needs more time than in a more or less humid wall layers to reach the surface and dry out there. An experienced specialist company should therefore be commissioned for the drying process.

Depending on the type of drying, ensure that there is sufficient ventilation to remove the moisture from the room.

Especially in areas of formerly damp wall sections, it is also recommended to use a lime or lime-cement plaster that is as vapour-permeable as possible on the room side.

3.3.4 Sealing measures

If the evaluation of the as-built analysis has determined that moisture loads are present as a result of rising damp and splash water loads, the installation of subsequent waterproofing for building components in contact with the ground and building components in the plinth area is an effective measure for restoring the protective function and significantly reducing moisture loads. In many older existing buildings or buildings that were originally unheated, there is often no sealing.

To ensure reliable functionality of the sealing measures, various factors must be taken into account at the planning stage in order to select and dimension the appropriate sealing system. These are, for example, resistance to external influences, crack limitation and service class.

Many sealing systems that have been tried and tested in practice are covered by the guideline DIN 18533 [8]. Depending on the condition of the existing structure, different solutions are available for sealing building components in contact with the ground. However, there are some limitations to each of these methods. Depending on the method, these include, for example, a large necessary working space, the type of wall construction (e.g. quarry stone masonry, inhomogeneities, presence of hollow layers), the existing masonry moisture or the sensitivity of the building to vibrations. Which of the methods presented here is best to use can be decided by the planner or a specialist engineer.

The functionality of the entire sealing system can only be ensured if the individual components are connected permanently and with the necessary overlap.

A complete sealing system consists of several components:

- External vertical sealing in contact with the ground or internal vertical sealing (against capillary water from the ground)
- External sealing in the plinth area (splash water protection)
- Horizontal sealing in walls (rising damp)
- Horizontal surface sealing on the floor slab

A description of the sealing components and some of the sealing methods can be found in the appendix A I.

3.3.5 Consideration of salts

Moisture damage to façades often occurs in connection with salt damage. Excessive moisture in building components causes salts to be dissolved inside the wall and transported to zones with lower moisture (e.g. surface), where the conditions for crystallisation are often present, possibly also causing damage. In the context of a retrofitting measure for a salt-contaminated façade, the causes of the moisture and salt contamination (e.g. contamination by nitrates in the case of former stable use, by chlorides in the case of the use of road salts or by dissolved salts due to masonry moisture penetration and inputs from the soil) must first be examined and measures taken to eliminate them (e.g. blocking, drying...).

Common damage patterns are e.g.:

- Efflorescence of salts, crust formation on surfaces
- Damage due to salt crystallisation (e.g. spalling and shell formation), also within the stone structure as a result of volume increase and crystallisation pressure in the case of insufficiently resistant materials.
- Hygroscopic water damage, visible through damp spots, often with damaged surface; in this case, moisture from the room air is bound in salt-contaminated areas of a material.
- On plaster surfaces: Chipping of the paint with efflorescence (often in the plinth area, at the eaves or under window parapets).

After determining the cause, the type of salt and the degree of salinisation, necessary steps and eventually a renovation method can be derived. Simple test kits are available on the market to determine the most common types of salt. If there is salt damage (e.g. to the building fabric such as spalling), a specialist company should be commissioned to plan the rehabilitation.

There are various approaches and methods for salt reduction or salt remediation.

- During a drying measure, the salts will also reach the wall surface with the moisture transport and crystallise there. These must always be removed dry on the surface, e.g. by sweeping with a broom. If the wall remains dry after the drying measure, no further salt transport to the surface is to be expected in the future.
- In the case of brick-faced façades, the joints must be completely renovated up to at least 50 cm beyond the damaged areas.
- If the salt content is high, the salt-contaminated areas are removed, i.e. contaminated plaster or stones are removed and new plaster or stones are replaced.
- Application of chemical processes: This involves the conversion of easily soluble salts into poorly soluble or insoluble salts.
- Application of physical processes: Here, salts are brought into solution and transported to a defined location where they crystallise. This is achieved, for example, with wet compresses that are applied to the wall surface and removed again after the compresses are saturated with salts. The mode of action and procedure is described in the WTA-guideline 3-13-19 [9].
- Often, special coatings and plaster systems are used. The best known of these are hydrophobic renovation plasters with high water vapour permeability and reduced capillary conductivity, see for it WTA-guideline 2-9-20 [10]. If the restoration plaster becomes too saturated due to the existing salt load, it must be removed ("sacrificial plaster"). By now, plasters and panels are also being offered that are supposed to be able to absorb the salts and store them in the material matrix without damage. The long-term performance of such products has yet to be proven.

3.4 Notes on driving rain / splash water protection

3.4.1 Requirements

A decisive boundary condition for the dimensioning of interior insulation systems is the driving rain load of a façade. Therefore, it must be examined whether driving rain is relevant for the façade under consideration. If there is no or a low driving rain load, no driving rain protection measures are necessary.

In some cases driving rain can cause a considerable moisture load, which can increase the risk of damage (high moisture content, ice formation) in the existing masonry when using interior insulation. The drying potential is reduced after installing the interior insulation due to the lower temperature level of the existing wall and the higher diffusion resistance towards the interior.

To ensure driving rain protection of façades, the amount of precipitation absorbed must be limited in such a way that neither long-term moisture accumulation nor critical water contents occur.

Important factors influencing driving rain exposure are orientation, geographical location (protected or unprotected) and building height; driving rain exposure increases with increasing height. Mostly, west or southwest facing façades are exposed to the weather side and thus to the most rain. This is particularly relevant for thin, single-shell walls or exposed masonry (see Part I, Chap. 4.3).

The driving rain load is generally dependent on how large the precipitation sum and how strong the wind load are at a location. The following map (Fig. 4 left) of the annual precipitation totals shows that a lower load of less than 600 mm per year is recorded in various lowlands, e.g. Magdeburger Börde, Thuringian Basin, Upper Rhine Plain. A precipitation load of up to twice as high, over

1000 mm per year, can be expected for the Alpine foreland and the low mountain ranges (e.g. Black Forest, Bohemian Forest, Thuringian Forest, Harz).

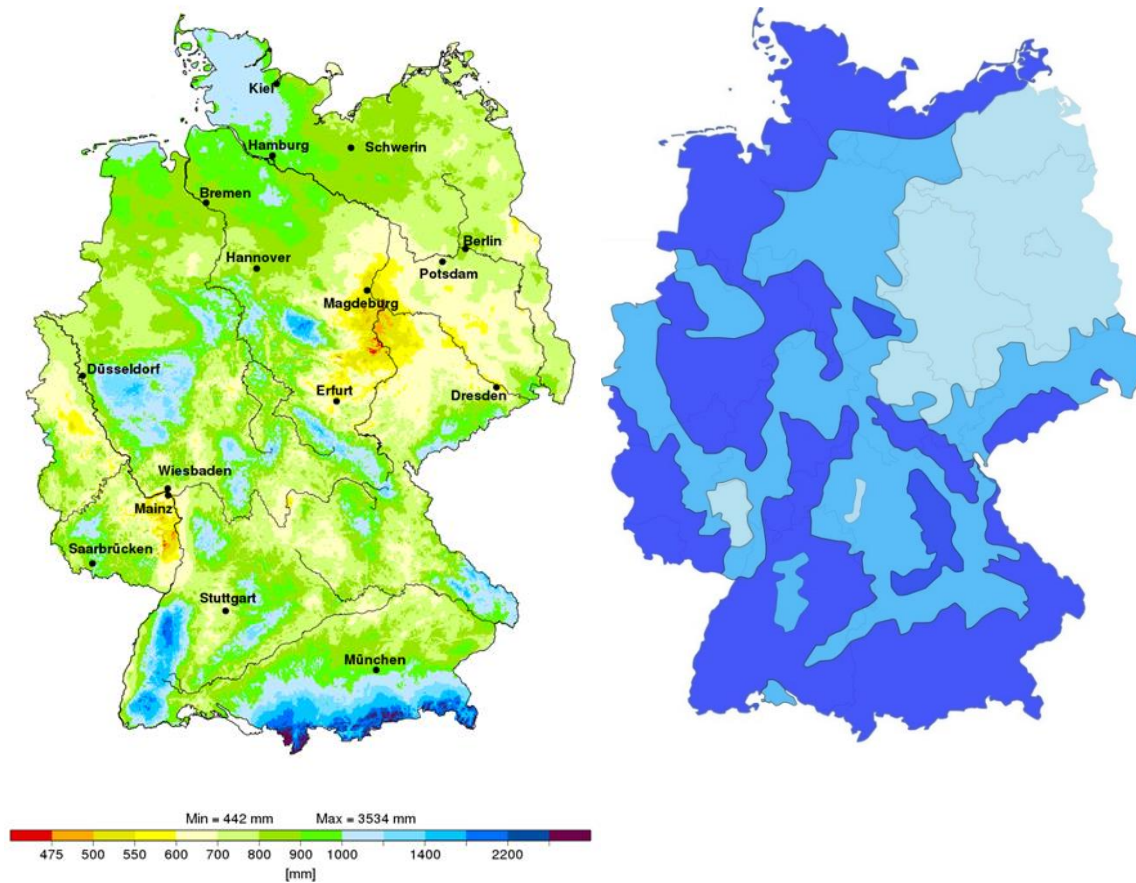

Fig. 4 Left: Annual precipitation totals in Germany according to long-term measurements in the years 1961-1990 (Source: Deutscher Wetterdienst: Klimaatlas Deutschland, www.dwd.de) and Right: Precipitation zones derived from this according to DIN 4108-3 [5], (Source: T. Duzia, Wuppertal)

The moisture protection standard DIN 4108-3 [5] also classifies the driving rain load according to the averaged sums of annual precipitation. This standard distinguishes between three driving rain load groups and assigns them by map. In the allocation of the driving rain load in the aforementioned standard, large-scale conditions of the horizontally measured precipitation are not exclusively decisive. As already explained, a driving rain load results from the interaction of precipitation (horizontal) and wind conditions. The zoning reflects this interaction. Therefore, for example, the coastal areas with moderate precipitation totals (e.g. the north-east of Mecklenburg-Vorpommern) are assigned to the highest stress group due to the wind conditions.

Tab. 1 Classification of driving rain load groups in DIN 4108-3 [5]

Driving rain load group	I	II	III
Total annual precipitation in mm	< 600	600-800	>800
Colour code in Fig. 4			

The local wind conditions must also be taken into account. If a building is located in a wind-exposed location, e.g. on a mountain, it is to be assigned to the higher load group. This also applies to wind-protected locations, which can be assigned to the lower group in each case.

The driving rain load must be known for dimensioning the insulation system. For many cases, it is sufficient to assign the location to the load group. For detailed calculations, a suitable design climate with hourly values has to be chosen.

In case of doubt, the specific load of the façade as well as its absorption behaviour can be determined by measurements and, e.g. by means of simulations, it can be examined whether the building component with the planned insulation measure will work under these conditions. This in turn requires the material parameters of the existing layers.

It is therefore usually easier to ensure protection against driving rain across the board, e.g. constructively by means of roof projections to protect the outer wall or by means of a cladding/ facing shell. This solution, which is ideal from a technical point of view, is often not desirable or feasible because of the change in the external appearance. If cladding is carried out, it is usually also possible to use (at least slight) external thermal insulation, which is usually preferable to internal insulation in terms of building physics.

Another option is to apply a new coating, a new plasters or sealing slurries.

The A - or A_{cap} value (water uptake coefficient, see Glossary in part 1) of the existing wall can be determined using various in-situ measurement methods with varying effort and accuracy (see Part I). These measurement methods are also partly suitable for checking hydrophobic measures. If it is not directly apparent whether a point on the façade is exposed to driving rain, simple cumulative driving rain measurement systems such [11] can be installed.

According to DIN 4108-3 [5] and WTA-guideline 6-5-14 [12] a sufficient driving rain protection for internally insulated building components is ensured if the following requirement for the exposed façade surface is met:

- $A \cdot s_d \leq 0.1 \text{ kg/mv/h}$
with $s_d \leq 1.0 \text{ m}$ and $A \leq 0.2 \text{ kg/m}^2\text{v/h}$

The s_d -value of a material layer is determined from $s_d = \text{thickness} * \mu\text{-value}$. This requirement can be deviated from at any time if the driving rain protection is provided by location, orientation, structural conditions and neighbouring buildings or other circumstances or if there is little or no exposure to driving rain.

If there is insufficient protection against driving rain, appropriate measures must be taken to ensure this. In the case of plaster facades, this is fulfilled with a suitable stable, crack-free exterior render according to the above requirements. Otherwise the protection can be ensured after necessary repairs/crack filling and a water-repellent coating or new rendering.

In the case of stone-faced façades where no constructive measures to reduce water absorption are possible, the use of hydrophobic agent can also be an option.

3.4.2 Hydrophobic measures

If no other measure is effective, it is possible to apply a hydrophobic agent to brick-faced masonry to reduce capillary water absorption. Diffusion-open agents, which are adapted to the existing bricks, are usually preferable. The coordination with other work steps of the renovation concept is necessary.

For the planning and application of a hydrophobic impregnation, an important decision-making aid is available in the form of WTA-guideline 3-17 [13]. It explains the necessary basics as well as the consideration of object-specific parameters and effects on the substrate. Furthermore, the modes of action of various systems and suggestions for planning measures are presented.

Knowledge of the existing substrate and the installed façade materials and their properties, including joints, is important before carrying out the planned measure.

This also includes finding out or checking whether the masonry to be treated is suitable for this. Prerequisites are, among other things, sufficiently low salt concentrations and, if possible, the absence or limitation of cracks in the masonry.

The information whether the façades have already received coatings in the past and which type it was is important for planning a new treatment. Alternatively, a chemical compatibility can be checked by laboratory tests, which is offered in building physics laboratories, but often also by the manufacturers of the hydrophobic systems.

Application of hydrophobing agents:

After cleaning the surface and renovating the joints and cracks, a hydrophobic impregnation is applied, which does not impair the diffusivity of the masonry and thus the drying potential, or at least as little as possible, but significantly reduces the driving rain absorption (to w -values below $0.2 \text{ kg/m}^2\text{v/h}$).

After the preliminary investigations and determination of the required penetration depth, suitable products are selected. These are first applied to sample surfaces that take into account the essential object properties with consideration of the stone and joint systems as well as the driving rain load. An untreated comparison surface is also to be provided.

Alternatively, the suitability of the selected agent for the specific façade can be tested in advance by means of laboratory tests. The adaptation to the existing construction is carried out in such a way that impregnation agents with different active ingredient concentrations are applied to different test specimens of the façade material on which the capillary water absorption was measured in the laboratory. After a defined exposure time, the capillary water absorption is measured again and evaluated with regard to the ideal active ingredient content. This also makes it possible to determine whether special features of the application (e.g. exposure time) need to be taken into account and whether there are any incompatibilities with previously applied agents.

Impregnation is best carried out after long periods of dry weather.

The instrument of hygrothermal simulation makes it possible to estimate more precisely the chances of success of renovation measures such as hydrophobisation (see Appendix A VI - Characteristic values, boundary conditions and evaluation criteria for hygrothermal simulations). The first of the following three pictures show the humidity distribution of a brick-faced existing structure without sufficient driving rain protection (Fig. 5 left) on a winter day. Next to it, this construction is shown with a 5 cm thick capillary conductive, diffusion-open interior insulation (here: perlite insulation). It can be seen that without additional driving rain protection measures, the moisture load on the exterior wall increases when interior insulation is used compared to the initial state, because the drying potential is limited by the lower heat input from the interior and the higher diffusion resistance to the interior. Thus, driving rain on the façade side can no longer dry to the same extent as before. Moistening of the construction can take place, which can lead to an increased risk of frost in the case of materials that are not frost-resistant.

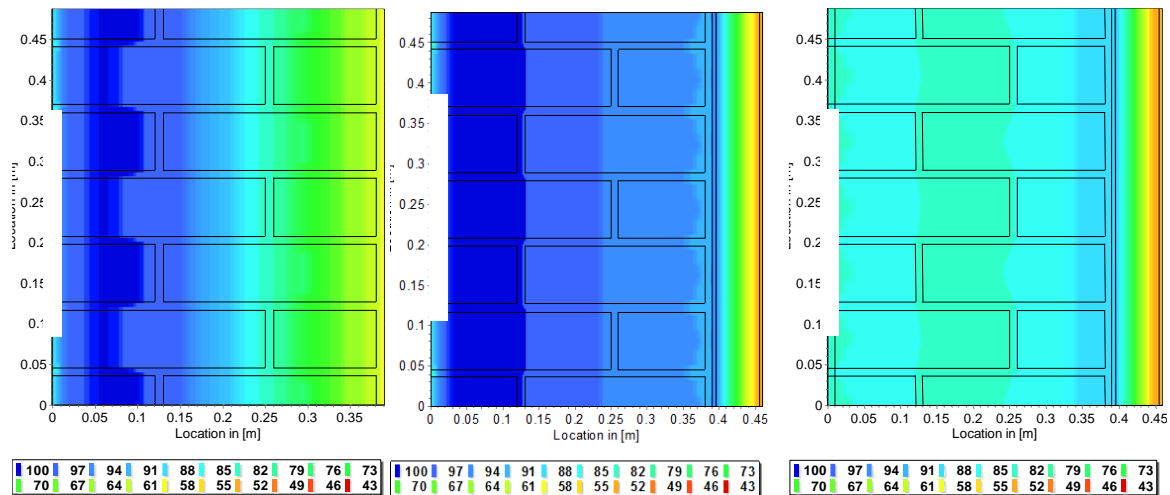

Fig. 5 Simulation of an uninsulated brick wall (left) and with 5 cm Perlite internal insulation (centre and right), right with hydrophobic coating; fields on 24.2. of the third calculation year.

A hydrophobic impregnation of the exterior surface adapted to the existing structure is a possibility to reduce the capillary water absorption of the façade without limiting the drying potential in vapour form to the outside. In Fig. 5 right, it is shown that hydrophobic impregnation leads to uncritical conditions.

A basic prerequisite for a hydrophobing measure on a façade that is not intact is the prior implementation of sufficient façade retrofitting with crack and joint repair and, if necessary, with partial material replacement.

If this is not done, there is a danger that driving rain will get behind the hydrophobic layer via the damaged areas and accumulates. The wall would still dry out diffusively, but the additional moisture that has penetrated cannot be compensated. Through such unprofessional "renovations", a hydrophobic coating can even promote damage.

The application of water repellents without matching them to the building's façade material carries the risk that the water repellent will be ineffective or (far) below its potential.

It should be noted that hydrophobing agents must be renewed every 5 to 15 years.

3.4.3 Exposed façade elements

For undisturbed façades, driving rain protection can usually be fulfilled with one of the previously explained measures. However, façades are often equipped with exposed elements. It is necessary that these elements are and remain in good condition, are made of suitable materials and have the correct shape/form and dimensions. In the case of listed façades, coordination with the heritage protection authority must take place in advance regarding the possible changes.

Examples of such façade elements are cornices and plinth projections in the façade, bossage, cornices, stucco and decorative elements, construction transitions, joints, window joints, balcony joints, etc.

Window sills, for example, should be made of a compact and ideally continuous material that has no or very low capillary water absorption and is frost-resistant. If they consist of several elements, they should be constructed in such a way that any water penetrating via joints is efficiently led away from the façade. This can be achieved by a small "gutter" under each joint or by a waterproof membrane under the entire window sill. Ideally, the window sill should protrude a few centimetres from the façade with a drip edge, slope away from the façade with a gradient and have an edging on both sides that prevents water from flowing sideways from the window sill into the structure.



Fig. 6 Professional execution in two very different examples: Window sill in each case made of one piece (natural stone or sheet metal), window sill is inclined, protrudes from the façade, with vertical ends (not visible in the photo on the left), with drainage groove.



Fig. 7 Unfavourable design: window sill does not protrude from the façade (left) or no edging of the window sill (right), so that rain can penetrate directly into the façade and cause damage.

3.5 Measures for plaster facades

In the case of **plaster facades** without damage with an intact or newly applied exterior plaster, protection against driving rain is usually provided or can be achieved by partial repairs in connection with a coating. If the plaster layer subsequently fulfils the requirements according to WTA guideline 6-5 [12], no separate planning services need to be provided. If the general requirements are not met, the suitability of the plaster system for the specific situation can be proven in individual cases, e.g. with the help of measurements (see guideline part I) a hygrothermal simulation.

For façades with cracks, a crack classification is used to check what type of cracks are involved (e.g. causes of cracks from the construction, from the plaster substrate, from the execution of the plaster work, the mortar composition, use of unsuitable coatings or from an overlapping of different causes).

From this, necessary measures for repair procedures on the façade can be derived.

For the assessment, determination of investigation measures and selection of repair procedures for cracked plasters on facades, reference is made to the WTA guideline 2-4 [14].

There, procedures for the repair of individual cracks (procedures E1 to E6) as well as procedures for surface repair (procedures F1 to F8) are described, each depending on the type of crack and the existing surface.

If a renovation plaster is to be applied due to salt contamination, please refer to the WTA guideline 2-9.

When repairing or replacing plasters, vapour-permeable plasters should also be used, if possible, which do not or only marginally restrict the drying potential, but sufficiently prevent the penetration of driving rain, see for it WTA guideline 6-5 [12]. Newly applied water-repellent coatings are preferably highly permeable to water vapour, especially if the underlying masonry is sensitive to frost. Silicate paints, siloxane paints and lime paints are well suited for this purpose. Acrylic paints are less permeable to water vapour. Epoxy, polyurethane and oil paints, on the other hand, are highly vapour-retardant and should be avoided on exterior surfaces, if possible.

3.6 Measures for exposed masonry

Since the renovation of exposed façades (e.g. brick or natural stone) is usually more demanding to plan and execute than plaster renovation, this topic is dealt with more extensively. As with plaster facades, any existing moisture and salt damage in the construction areas under consideration must first be treated, drying phases must be planned and, if necessary, appropriate sealing measures must be provided.

3.6.1 Façade cleaning

Before further façade maintenance and renovation work, it is usually necessary to clean the façade, e.g. to remove loose façade components. The aim is to obtain a solid, cleaned façade surface (free of algae, salts, soot particles, tyre abrasion, etc.) that is suitable for the further renovation steps. The surfaces of brick and clinker facades should be cleaned using a method that is as gentle as possible so as not to damage the firing skin of the bricks. Methods such as sandblasting are therefore unsuitable.

As the simplest method, the use of a superheated steam jet is recommended. For many surfaces, cleaning without chemical additives is already sufficient. In individual areas, special surfactants, algae solvents, etc. can be used depending on the condition found. The cleaning agents used must be matched to each other and with the hydrophobic impregnation that may follow. It must be considered that cleaning solutions must be collected and disposed of what should be included in the calculation what should be included in the calculation what should be included in the calculation.

It is recommended to create a test area on which the cleaning result can be examined.

3.6.2 Crack renovation

Cracks in the façade (flank cracks at joints, cracks in the brick itself or statically induced cracks) are weak points in the construction that disrupt the protective function of the building envelope in terms of building physics. If driving rain and frost penetrates the masonry, serious damage can occur. If not only the façade surface is affected by cracks, but also the construction itself, there is often also a structural problem. Therefore, crack repair is of great importance in the context of an energetic renovation.

After a crack mapping and, if necessary, a static assessment, a cause-related differentiation is first made as to whether the cracks are caused by the structure, the underground or the material, in order to be able to derive necessary measures. This is done by recording the crack depth, width, length and the course of the crack. By e.g. placing plaster marks, it can be checked whether the cracks are still dynamic.

Depending on the type and spread of the cracks, the proposals for repairing them can range from replacing the pointing mortar up to the use of stainless steel spiral anchors, which are used in the event of structural problems.

3.6.3 Joint renovation

Often the bond between the masonry stones and the mortar has been demolished, so that the tightness of the façade must be restored here with joint renovation.

The following steps are necessary for this:

- Removal of the (defective) pointing mortar to a depth of approx. 20 mm, avoiding damage to the stones.
- Re-pointing with a water-repellent, weather- and frost-resistant repair mortar matched to the construction in terms of strength, elasticity and colour, which does not hinder the drying potential of the laying mortar. Optimally, the new pointing has better rainproofing properties than the stone itself – then, any necessary dimensioning of the component can be carried out on the basis of the brick properties.
- In splash water areas: pointing with a mortar suitable for the plinth area.
- Post-treatment or shaping of the joint

3.6.4 Criteria for material exchange

Damaged bricks in the façade must be replaced with materials with adequate material parameters. In the best case, this can be done with on-site, well-preserved masonry blocks that are left over in the course of the renovation, e.g. by the expansion or addition of openings. Otherwise, suitable replacement bricks are to be used.

This requires a classification of the existing materials to determine their properties. The selection of the replacement bricks is carried out in adaptation to the existing material. The following (hygrothermal) material parameters must be taken into account:

- Water absorption capacity (similar to the existing brick or slightly less absorbent)
- Strength
- Bulk density
- Frost resistance (durability)
- Type of stone: solid, perforated brick, similar replacement
- Surface and colour

If this is not taken into account, experience has shown that differences can quickly become apparent on the façade, e.g. due to different moisture absorption up to back moisture and the formation of shells. The replacement mortar to be used should also be as similar as possible to the existing mortar, although different or changed weather conditions must also be considered.



Fig. 8 Existing horizontally perforated brick in the façade: left photo during the as-built analysis, right photo after renovation

3.6.5 Antigraffiti protection

The removal of graffiti from the façade usually causes high costs. If desired as part of the renovation measure, an anti-graffiti coating can be applied to the finished façade. These are systems that prevent the deeper penetration of paint layers from graffiti sprays. Thus, the paint remains on the surface and can be easily removed by suitable cleaning procedures.

Depending on the system chosen, such a coating can influence the drying behaviour of the façade and any hydrophobic measures applied.

The (mostly water vapour-permeable) systems are classified according to their removability and durability.

Temporary systems:

Silicone-based systems: When cleaned, the system dissolves together with the graffiti and must therefore be renewed

Semi-permanent systems:

- a. Single-layer system: protective layer is partially removed during cleaning, partial renewal required after a cleaning measure, use of hydro- and oleophobic systems.
- b. Two-layer system: permanent primer + temporary protective layer, dissolution of the protective layer during cleaning together with the graffiti, only protective layer has to be renewed.

Permanent systems:

System with several layers that remain permanently on or in the substrate, resistant to cleaning, increases the diffusion resistance of the façade and delays drying out, coating system mostly polyurethane-based.

4 Development of an insulation concept

4.1 Determination of desired insulation standard

Based on the findings from the inventory analysis, moisture screening, effective driving rain load as well as material investigations, an insulation concept for the energetic refurbishment of the specific building can be developed.

In the course of the processing, the following questions must first be clarified together with the client:

- Is it primarily a matter of complying with the minimum thermal insulation and thus only of being damage-free, or is a certain level of insulation to be achieved, e.g. in order to claim subsidies?
- Should the building be completely renovated in one overall measure or at least in a combination of measures?
- Are only individual measures planned (which, however, may require other measures)?
- What is the available budget?
- What is the planned utilisation concept? Are there strongly differing uses within the building, e.g. with increased moisture loads?
- Are there increased fire protection or sound insulation requirements that need to be taken into account?
- When selecting the interior insulation system, does a strong mechanical stress on the surface has to be taken into account?
- Is the placement of wall cabinets planned, for example in kitchens (so that additional anchoring measures may be necessary)?
- How are the room-side surfaces finished (e.g. plaster in living rooms, tiles in wet rooms)?

First, the target range of the desired U-value is jointly determined. In order to identify which insulation thickness is required for the determined thermal insulation, the U-value of the existing exterior wall construction (e.g. in old buildings with brick constructions usually approx. 1.3 - 1.5 W/(m²·K) with an exterior wall thickness of 36.5 cm) is detected, on the basis of the material investigations or according to literature research (e.g. <http://altbaukonstruktionen.de> [15] oder <https://www.masea-ensan.de> [16])

The following figure shows the effect of different insulation thicknesses and thermal conductivities on the U-value. For this, an U-value of 1.32 W/(m²·K) was assumed for the existing construction. With an U-value of < 0.73 W/(m²·K), the minimum thermal insulation for exterior walls is met. The figure shows that with a thermal conductivity for interior insulation of 0.025 - 0.30 W/(m·K) (e.g. rigid PUR foam), the minimum thermal protection is already achieved with an insulation thickness of 2 cm. With a thermal conductivity of 0.075 W/(m·K), as is the case with certain insulating plasters, for example, at least 5 cm are required.

The rapid drop at the beginning also shows that the first centimetres of insulation have the strongest influence on the U-value. Depending on the existing construction and remaining thermal bridges, high insulation thicknesses have hardly any effect in terms of energy, apart from other problems that arise with increasing insulation thickness (e.g. loss of space).

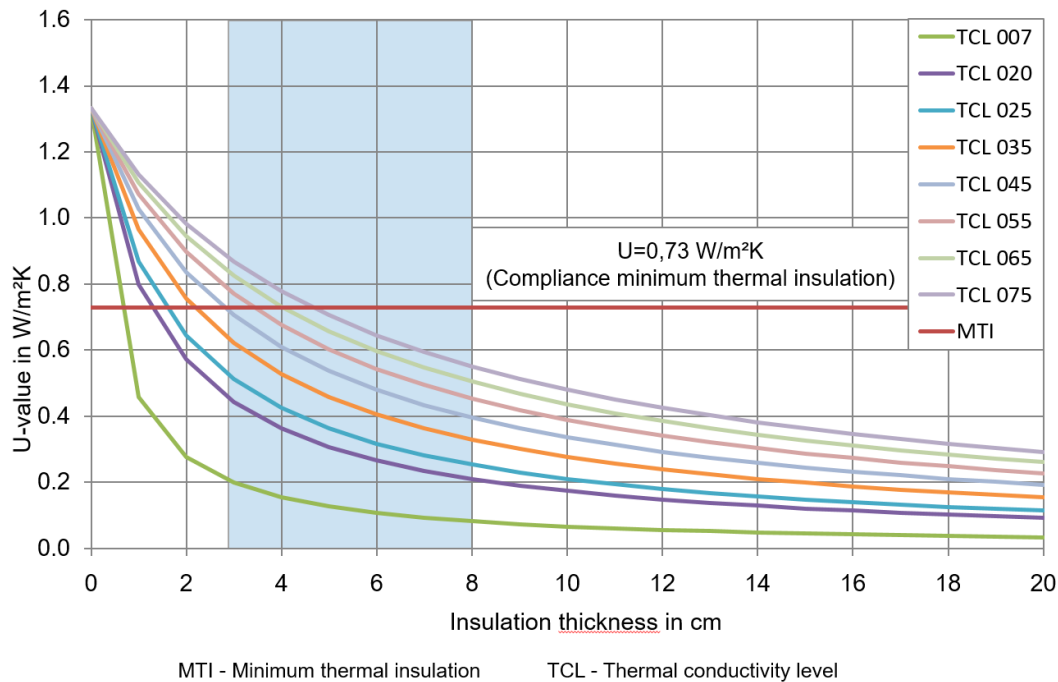

Fig. 9 Dependency of the U-value on the insulation thickness and the thermal conductivity level (TCL) of the insulation material, usual insulation thicknesses highlighted in blue

4.2 Selection of possible insulation systems

4.2.1 Selection criteria

Regardless of the conditions in the individual building, some principles must be observed when applying interior insulation. Basically, the following applies:

1. The lower the moisture load from inside and outside, the greater the choice of possible interior insulation systems.
2. If there is no moisture entry from the outside, almost all common interior insulation systems can be used. The installation of vapour-retardant or even vapour-tight interior insulation is a favourable solution in this case, as it also minimises the entry of moisture from the room side - this applies in particular to rather high moisture loads in the interior.
3. If, on the other hand, there are other sources of moisture from the outside in addition to diffusion transport from the indoor climate, these can often only be eliminated with great effort or not at all. It can require drying potential also towards the interior and limit the choice of suitable materials as well as the permissible insulation thickness accordingly. The principle: as vapour-tight as necessary, as vapour-open as possible, should be observed especially for moisture-sensitive constructions with moisture loads from the outside.
4. The better (lower) the U-value of the existing structure, the lower the risk of condensation for the interior insulation.

Based on the preliminary investigations, it must be examined whether there are any fundamental restrictions in the selection of the insulation system. These are, for example, structural or physical limitations.

Constructional restrictions**Wall condition and flatness of the wall**

A relatively even surface is required for board-type insulation materials that are bonded to the existing wall. This may require the application of a base coat/levelling plaster. If the walls are too uneven, the use of e.g. an insulating plaster can be considered as an alternative.

Suitability of wall surface and load-bearing capacity of the existing wall

It must be checked in advance whether the wall with the existing interior plaster can accommodate the planned interior insulation system. Non-load-bearing layers (such as loose existing plaster) on the existing wall must be removed beforehand. The same applies to wallpaper and some gypsum-containing substrates in case of moisture penetration from the outside. If the existing wall itself is not able to support the insulation system, a self-supporting insulation construction can be attached.

Material-specific incompatibilities

Before applying the interior insulation, it has to be examined whether there are materials in the existing structure that trigger undesired chemical reactions with components of the insulation system, e.g. in the case of existing steel elements, the reaction with other metals or with adhesive mortars, clay or gypsum plasters can trigger corrosion.

Mechanical stress on the surface

Depending on the planned use, it is necessary to consider in advance what mechanical stress the future internal surface will have to withstand. For childcare facilities or sports halls, for example, the surface materials must be designed to withstand mechanical stress (e.g. thicker plaster layer with fabric insert) and a more abrasion-resistant surface coating must be used than for normal residential or office use.

Building physics restrictions**Drying potential of the existing wall**

The more vapour-permeable the construction of the existing wall is, the higher the drying potential to the outside (and inside). This means that moisture that has penetrated the construction can diffuse more quickly to the inside or outside again than in the case of impermeable walls. For vapour-permeable existing constructions, a larger number of possible interior insulation systems are available than for vapour-tight exterior walls.

In the case of walls in contact with the ground, the drying potential is lower, as the ground temperatures are subject to minor fluctuations throughout the year and rarely move above 15°C. In addition, there is no air exchange with the environment.

Moisture resistance of the existing wall, moisture related properties

The underground of an interior insulation system can be moisture-resistant or moisture-sensitive. If there are restrictions in this regard, e.g. in the case of gypsum-containing substrates or wooden components in the construction, care must be taken when selecting the interior insulation system to ensure that the future moisture content in these areas does not increase impermissibly. This can be demonstrated, for example, by hygrothermal simulations, whereby reference is made to the WTA-guideline 6-2-14 [18].

Utilization concept

When pre-selecting insulation systems, the future planned use should be taken into account. In addition to the basic temperature and humidity-related boundary conditions, this also applies to

times of use, peak loads to be taken into account, etc. For example, the focus is different for swimming pool use than for the use of an assembly room or museum, storage for art objects/instruments or with precisely defined usage boundary conditions. The choice of insulation systems can also be limited if the requirements for use differ to a high extent.

Fire protection and sound insulation requirements

Not all insulation systems are suitable for every installation situation from a fire protection and sound insulation point of view. For example, for escape routes and walls/floor ceilings between units in use, other requirements regarding fire protection and/or sound insulation must be considered. Furthermore, it should be noted that “hard” insulation boards, e.g. PUR boards, tend to behave less favourably than fibrous insulation materials with regard to sound insulation.

Economical preselection

The insulation systems available on the market differ considerably in terms of their costs, whereby the complete insulation system, including the processing, must always be considered. In some cases, the insulation materials themselves are inexpensive, but the associated components are cost-intensive. Or the operations for applying the system to the walls, including necessary preparatory work, are time-consuming, so that the costs increase as a result. In other cases, a more cost-intensive but highly efficient slim line thermal insulation system can also make sense for a very high-priced floor space.

4.2.2 Classification of interior insulation systems

Fig. 10 gives an overview of typical interior insulation systems and their moisture behaviour in winter and summer – the latter is normally rather unproblematic, therefore the special case of a wetted wall e.g. by rain absorption from the outside is presented here. On the left is a vapour permeable fibre insulation (without a vapour retarder). In winter, condensation can form on the cold side of the insulation. This is tolerable to a certain degree with an absorbent substrate, but it causes moisture entry into the existing wall. In summer, the moisture by driving rain or condensation can dry out well inwards through the vapour permeable insulation, but such a solution is still only acceptable for improving comfort and hygiene up to a thickness of a few centimetres. For thicker insulation layers, an additional vapour retarder is required (middle left), which significantly reduces moisture entry via diffusion in winter. In summer, however, due to a constant high s_d -value, it also affects the potentially required drying to the inside in some cases or can even lead to condensation in the insulation due to inverse vapour diffusion from humid masonry. In principle, vapour retarding rigid foam insulations (middle right) without a separate vapour retarder behave similarly. They also protect against moisture from the indoor climate in winter, but also limit drying in summer. Both insulation systems generally have very favourable insulating properties and are always advantageous when there is no moisture entry from the outside, like in case of good rain water protection and a dry wall.

Interior insulation systems

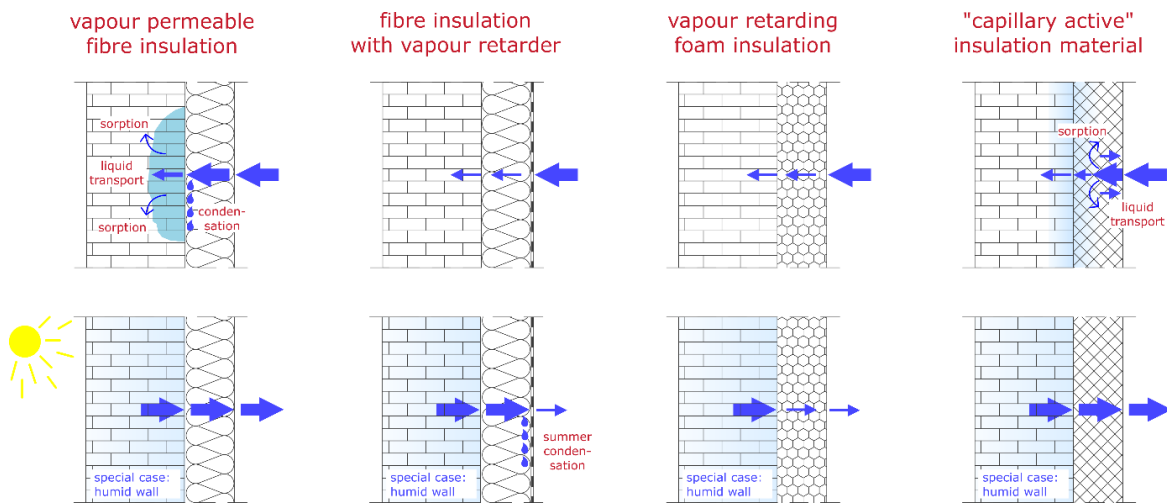

Fig. 10 Overview of various interior insulation systems and their moisture behaviour in winter (top) and summer (bottom) for the special case of a humid wall (e.g. caused by water rain absorption) which needs to dry towards the inside

If the driving rain protection cannot be improved to the desired level, the possibility of drying inwards in summer should not be restricted too much. This is particularly important for moisture-sensitive building components such as timber-framed walls with wooden components. In this case, the WTA guideline 8-5 on internal insulation of timber-framed walls requires that the internal diffusion resistance must be limited to a maximum of 2 m s_d -value. Here, so-called capillary-active interior insulation offers advantages (shown on the right in Fig. 10), as they limit the increase of the moisture level in winter not with a vapour retarding membrane, but by moisture capacity and capillary back transport. In summer, such systems allow almost unhindered drying to the inside. Also in the case of a vapour permeable fibre insulation in combination with suitable so-called moisture-variable vapour retarders, the humidification and drying behaviour is very favourable (not shown separately in the figure). Such membranes behave like a vapour retarder in winter and hardly allow any moisture entry into the wall, while they become much more vapour permeable under drying conditions in summer and allow for a rapid drying towards the inside.

So-called high-performance insulation materials such as aerogels or vacuum insulation are being used more and more frequently in joint areas and in connection parts, which still achieve a good insulation performance even with low material thicknesses. They are also interesting for application in the regular cross section in case of low moisture load from the outside – however, they are usually much more expensive than conventional insulation materials in that case. For some years now, there have also been so-called “hybrid” interior insulation systems, which combine the advantages of conventional insulations with those of capillary-active insulation materials – usually by a combination of corresponding materials. Since they are similar to capillary-active insulation materials in terms of their function, they can be used in a similar way regarding advantages and disadvantages.

If individual technical material or system properties are considered, interior insulations are primarily classified according to their vapour diffusion resistance. The s_d -value, which is calculated as follows, is a suitable parameter for both a system and a layer:

$$s_d = \mu \cdot d$$

The μ -value is the diffusion resistance coefficient of the material and d is its layer thickness. If there are several layers, the total s_d -value can simply be summed up. The diffusion resistance coefficient indicates the factor by which the material is more vapour retarding than a stagnant air layer with the same thickness, which is used as a reference. Accordingly, the s_d -value is the diffusion-equivalent air layer thickness and describes how thick a layer of stagnant air would be, which corresponds to the layer or system in terms of vapour diffusion resistance.

According to DIN 4108-3 [5], the s_d -values are classified into six groups, which are shown in the following table.

Tab. 2 Classification of building component layers according to the s_d -value based on DIN 4108-3 [5]

Component layer	s_d -value
vapour-permeable	\leq
vapour-retarding	$0.5 \text{ m} < s_d \leq 10 \text{ m}$
vapour-inhibiting	$10 \text{ m} < s_d \leq 100 \text{ m}$
vapour-blocking	$100 \text{ m} < s_d \leq 1500 \text{ m}$
vapour-tight	$\geq 1500 \text{ m}$
with variable s_d value	Material layer that changes its s_d -value depending on the RH of the ambient air

Based on this classification, interior insulation systems are assigned into three categories:

- vapour tight, blocking and retarding interior insulation system with $s_d \geq 10 \text{ m}$
- vapour retarding interior insulation system with $0.5 \text{ m} < s_d \leq 10 \text{ m}$
- vapour permeable, variable or capillary-active interior insulation system with $s_d \leq 0.5 \text{ m}$ (with variable vapour retarders, the summer value at correspondingly high RH is relevant).

The different insulation systems are described below. Vapour retarders with variable s_d -values have the special property that they become more vapour tight at low indoor air RH in winter and more vapour permeable at higher indoor air RH in summer as well as generally at drying conditions towards the interior, when moisture accumulates at the membrane. As a result, a comparatively low moisture entry in winter is counterbalanced by a particularly large drying potential in summer, which leads to constructions with a higher fault tolerance. The same applies to the capillary-active and moisture absorbing systems.

On the interior side, all systems must have airtight connections, especially at penetration areas. Due to the rather low fault tolerance of vapour blocking and vapour tight systems, the penetrations must also be performed in a particularly vapour tight manner.

Vapour tight, blocking and inhibiting interior insulation systems

Using these systems, the vapour diffusion flow from the indoor climate into the wall is largely prevented when properly installed. This means that no increased moisture content is to be expected in the interface between the existing masonry and the interior insulation due to the moisture entry from the indoor climate. On the external side, a suitable driving rain protection (see chapter 3.4) must be ensured. This must be consequently ensured during planning and implementation. Such insulation systems are usually used for humid rooms (such as swimming pools). Here, either insulation materials are used that are themselves vapour-tight or retarding (e.g. foam glass, foam

insulation materials or similar), or system's vapour-tightness is ensured by a vapour retarder installed on the room side of the insulation layer (usually fibre insulation such as mineral fibre or wood fibre). It should be noted that moisture that enters the construction due to imperfections or driving rain can hardly dry out towards the interior and can lead to an accumulation of moisture behind the insulation layer if the external layers are not vapour permeable enough to evaporate the moisture towards the exterior.

Vapour retarding interior insulation systems

Also with these systems, only a small amount of moisture enters through the vapour retarder. With a sufficiently low s_d -value of insulation system and the interior vapour retarder, a certain potential for drying towards the interior remains available. The acceptable moisture accumulation at the cold side of the insulation depends on the absorbency of the material (masonry or plaster) at this position. On the exterior surface, sufficient protection against driving rain must be ensured. Examples of such insulation are systems with vapour permeable insulation (e.g. fibre insulation materials) in combination with a vapour retarder or a vapour retarding insulation material such as EPS or XPS. There are also some vapour retarding insulation materials with capillary-active properties – so called hybrid materials, which would also fall in that category.

Vapour variable interior insulation systems

This category includes systems consisting of a vapour permeable insulation material (e.g. mineral fibre or natural fibre) in combination with a vapour retarder with a variable s_d -value. Ideally, the s_d value of this membrane is in the vapour retarding range with an s_d value about > 2 m in winter when the relative humidity in the heated indoor climate is low, and in the vapour permeable range < 0.5 m in summer, when the humidity dries out inwards and the relative humidity at the membrane is correspondingly high. The systems thus combine the advantages of the vapour retarding systems mentioned above with low moisture entry in winter and the vapour permeable systems described in the next chapter with high drying potential in summer.

Vapour permeable, capillary-active interior insulation systems

Here, insulation materials are used, that are vapour permeable and have a sufficient capillary conductivity to compensate moisture entry by vapour diffusion by means of capillary back transport, when the moisture level at the cold back side of the insulation is rising. Thus a certain level of vapour flow into the wall can be tolerated.

An increase of the moisture level at the interface between wall and interior insulation is acceptable, as far as it is limited to the RH conditions, the materials are able to tolerate without damages or at least to the storage capacity of the interface materials. To avoid running down of dew water, it is important to ensure that the bonding to the substrate is as complete as possible (especially when using rigid insulation boards). Common examples of these insulation systems are calcium silicate, perlite and mineral foam insulation. Clay insulation or insulating plasters also belong to this category.

Others

Vapour permeable insulation systems without capillary-active or variable properties are only possible to a very limited extent, e.g. to ensure the hygienic minimum insulation to avoid mould growth or surface condensation. In these cases the thermal improvement is limited to $\Delta R \leq 0.5 \text{ m}^2\text{K/W}$.

4.2.3 Selection of an interior insulation system

The decision on which type of insulation system can be used for the specific renovation project depends mainly on the driving rain load resp. protection, the absorbency of the inner surface material of the existing wall and the internal moisture load.

If there is no relevant rain water absorption and no extreme moisture loads occur in the room, a rather free selection can be taken from all available insulation systems.

If high moisture loads in the room are to be expected in case of constructions without relevant rain water absorption, vapour inhibiting, blocking or tight insulation systems are well suited. This applies even more, if no increased moisture content or condensation must occur at the interface layer between the existing wall and the interior insulation system, like in case of gypsum or natural materials. Here, in principle, it must be ensured, that no more moisture may enter the construction than can evaporate to the outside in the same time.

In other cases, where penetration of driving rain or other external moisture influences cannot be prevented and there are no moisture-sensitive substrates, insulation systems that allow for a drying to the inside should preferably be used, such as vapour permeable, capillary-active insulation systems or vapour permeable fibre insulation materials with moderate or variable vapour retarders.

In some cases, where a sufficient rain water protection on the outside cannot be achieved and moisture sensitive materials are involved, it might be necessary to limit the interior insulation measure to the minimum deemed to satisfy / verification free level according to the resp. national standards.

In the following, a selection of possible interior insulation systems from all 3 categories is presented. In this context, reference is made to further tables, e.g. [1], [2] and [3].

Tab. 3 Overview of selected insulation materials with the most important hygrothermal parameters

Insulation effect	Thermal conductivity λ [W/mK]			Vapor diffusion	Capillarity		Material type			Fire protection	Costs
	Min	Max	Mittel		Can be combined with vapor retarder/vapor barrier	Water absorption coefficient A_w [kg/m ² √h]	Min	Max	Organic		
Insulation boards	Aerogel (mats)	0.014	0.017	0.016	✓	0.024	0.03	✓		non combustible	€€€
	Expanded polystyrene (EPS)	0.032	0.045	0.039		0				flame retardant / normal flammable	€
	Extruded polystyrene (XPS)	0.028	0.042	0.035		0		✓		flame retardant / normal flammable	€
	Wood fibre board	0.037	0.070	0.054		0.1	30	✓		normal flammable	€
	Woodwool lightweight board	0.080	0.170	0.125	✓	0.4	0.6	✓		normal flammable	€
	Calcium silicate	0.060	0.090	0.075		40	80	✓		non combustible	€€€
	Cork	0.037	0.060	0.049		0.5		✓		normal flammable	€€
	Mineral foam	0.040	0.045	0.043		0.25	2	✓		non combustible	€€
	Perlite	0.042	0.055	0.049		100	120	✓		non combustible	€€
	Polyurethane (PUR)/ Polyisocyanurate (PIR)	0.023	0.030	0.027		0				non combustible	€€
	PUR with cap. Inclusions	0.026	0.033	0.030		0.78				flame retardant / normal flammable	€€
	Pyrogenic silica	0.018	0.021	0.020	✓	0				non combustible	€€€
	Foam glass	0.037	0.060	0.049		0				normal flammable	€€€
	Reed	0.055	0.090	0.073		0.9	1.3	✓		normal flammable	€€
	Vacuum insulation panel (VIP)	0.007	0.009	0.008		0				normal flammable	€€€
Thermal insulation clay	0.068	0.085	0.077		1.4	5	✓		normal flammable	€€	
Compartment insulation	Hemp	0.039	0.050	0.045	✓	4		✓		normal flammable	€€
	Wood fibre	0.036	0.038	0.037	✓	0.4	0.7	✓		normal flammable	€
	Mineral fibre	0.032	0.045	0.039	✓	0				non combustible	€
	Sheep wool	0.032	0.045	0.039	✓	0.4	0.6	✓		normal flammable	€
	Straw	0.038	0.067	0.053	✓	2	3.3	✓		normal flammable	€
Cellulose	0.034	0.045	0.040	✓	12		✓		normal flammable	€	
Plastic Insulation materials	Light clay/ thermal insulation clay	0.070	0.250	0.160		3	8	✓		non combustible - normal flammable	€€
	Thermal insulation plaster mineral	0.021	0.080	0.051		1	10	✓		non combustible	€€
	Thermal insulation plaster organic	0.045	0.080	0.063		1	10	✓		normal flammable	€€
	Cellulose fibre plaster	0.050	0.060	0.055		3	4	✓		normal flammable	€€
Brick facing shells	0.055	0.100	0.078		0.2	30	✓		non combustible - normal flammable	€€€	

4.3 Overview of the most important evaluation criteria

In order to have an overview of the design parameters during the processing, the most important evaluation criteria for the application of interior insulations are summarized in the following table. All limit values listed here apply to Germany respectively to Central European Climate. In other countries, the regional regulations and, if necessary, deviating limit values must be used.

Tab. 4 Limit values and evaluation criteria and their source

Evaluation criteria	Source	Unit	Limit value
Minimum thermal protection (R-value)	DIN 4108-2	m ² K/W	1.2
Wood protection (steady state)	DIN 68800 as well as DIN 4108-3	M.%	< 20 M.% (solid wood) < 18 M.% (wood based materials)
Wood protection (transient)	WTA 6-8 DIN 4108-3 App. D	Rel. humidity of the air in the material pores	transient model or VTT-modell by Viitanen
Mould growth (steady state)	DIN 4108-2		f _{RSI} -value
Mould growth (transient)			transient model e.g. WUFI Bio, VTT by Viitanen or LIM-curves
Water contents of whole construction	WTA 6-5, DIN 4108-3 App. D	m ³ /m ³ or kg/kg	annual equilibrium state is reached
Rel. humidity at the interface between insulation and existing wall	WTA 6-5	%	< 95% RH for not frost resistant material
Saturation degree at the interface between insulation and existing wall	WTA 6-5	%	< 30% (or ensure the frost resistance of substrates)
Capillary water absorption and vapour permeability of facade	WTA 6-5		A·s _d ≤ 0.1 kg/mv/h with s _d ≤ 1,0 m and A ≤ 0.2 kg/m ² v/h

4.4 Hygrothermal behaviour of typical insulation systems

In the EneffID project [20], various representative interior insulation systems were investigated concerning their hygrothermal behaviour. Comprehensive scenarios were investigated, which cover the majority of cases occurring in practice. The results summarized in heat maps can therefore be directly referred to for planning purposes in specific projects.

For the parameter study in [20], four outdoor climate locations were considered: One representative location for each driving rain exposure group of DIN 4108-3:2014 (Potsdam for exposure group I, Hamburg for exposure group II, and Holzkirchen for exposure group III) as well as Fichtelberg as a worst-case location on the top of a mountain. In the indoor climate, different moisture loads were considered for different occupancies as residential and office buildings. Typical exterior wall constructions of solid brick, double-skin brick masonry, hollow brick and hollow concrete blocks with U-values between 1.3 and 1.5 W/m²K were considered. This meant that the vast majority of components in Germany could be covered on the safe side. The colour of the outer surface and

the vapour-retarding effect of the interior surface materials were also varied. The relevant evaluation parameters were used for the assessment:

- Mould risk on the interior surface
- Amount of condensation water in the insulation material in the case of hydrophobic mineral fibre insulation materials based on DIN 4108-3:2014
- Exceeding of the limit values of 30 percent of the maximum moisture saturation respectively 95 % relative humidity of the air in the pores at the interface layer between interior insulation and existing masonry according to WTA Guideline 6-5
- Exceedance of 30 percent of the maximum moisture saturation in the outer part of the existing masonry similar to the WTA guideline 6-5 requirements as a criterion for frost resistance
- Exceeding of the critical wood moisture content of 18 % by mass for wood fibre insulations according to DIN 68800-2:2012-02. This criterion is to be modified by the new results from the current In2EuroBuild project, since most natural fibre insulation materials used as interior insulation can verifiably tolerate higher moisture conditions.

The results of the moisture-related application ranges and limits were presented in comprehensive tables and heat maps. These are available in the publicly available EneffID project report and can be used for design purposes. A simplified qualitative summary of the application ranges can be found in the Appendix A IV .

5 Dimensioning and verification

When using interior insulation, an assessment of the moisture performance is crucial in addition to the thermal verification of the planned wall construction. This is to avoid damage due to insufficient measures or measures that are not adequate for the specific stock construction.

According to DIN 4108-3 [5] the verification of the moisture resistance of a building construction can be carried out using a three-stage assessment methodology, depending on the application:

1 st stage:	Verification-free / deemed to satisfy constructions according to DIN 4108-3
2 nd stage:	Simplified verification by dew point calculations / Periodic balance method according to DIN 4108-3
3 rd stage:	Verification by hygrothermal simulation

A simplified evaluation for interior insulation systems is possible according to the guideline in the WTA-guideline 6-4-16 [4], which correlates the required s_d value to the improvement of the insulation level ΔR and the absorbency of the interface between insulation and existing wall, whereby capillary-active, vapour permeable interior insulation systems are not included. Therefore a new verification for these materials is presented in chapter 5.3.

Simplified verification methods cannot be used for building components in contact with the ground, e.g. because of the deviating heat and moisture storage capacity. Simulation methods must be used for this. Vapour-tight systems are often suitable for this application.

5.1 Verification free / deemed to satisfy interior insulations according to DIN 4108-3

The German DIN 4108-3 [5] which regulates the moisture protection of building constructions defines basic measures with interior insulations which are seen as uncritical regarding their moisture performance under normal operation as dwelling or office building in Central European climate:

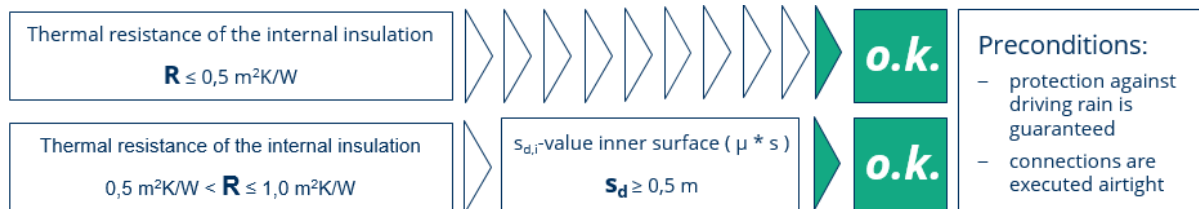

Fig. 11 General assumption of a verification-free / deemed to satisfy construction with an internal insulation system according to DIN 4108-3

A thin insulation layer with a thermal improvement of $\Delta R \leq 0.5 \text{ m}^2\text{K/W}$ can be applied without any additional requirements, if there is no driving rain load or a sufficient rain water protection and if no indoor air can flow behind the interior insulation layer. With the same prerequisites, the improvement can increase up to of $\Delta R \leq 1.0 \text{ m}^2\text{K/W}$ if there are vapour retarding layers at the interior surface with $s_d \geq 0.5 \text{ m}$ (Fig. 11). The thermal resistance R of a material layer is calculated from $R = \text{thickness} / \text{thermal conductivity}$.

5.2 Simplified verification for internal insulation

If the above mentioned limits of DIN 4108-3 [5] are exceeded, the simplified "Glaser"-method or EN 13788 [36] („Euro-Glaser“) can be used, which is described in the WTA Guideline 6-4-16 [4]. In this guideline, the procedure for planning interior insulation and the aspects of building physics are presented and the boundary conditions for the appropriate hygrothermal verification are defined.

The simplified verification according to WTA Guideline 6-4-16 may only be performed under certain conditions. The following conditions must be ensured for its applicability:

- Sufficient protection against driving rain must be granted so that no considerable moisture penetration is to be expected. This means:
 - no or limited exposure (location)
 - constructive protection (double-skin facade etc.)
 - rain-resistant exterior surface with the following properties:
 $A \cdot s_d \leq 0.1 \text{ kg}/(\text{m} \cdot \text{h}^{0.5})$ with $A \leq 0.2 \text{ kg}/(\text{m}^2 \cdot \text{h}^{0.5})$ and $s_d \leq 1 \text{ m}$
- No building component in contact with the ground or other moisture sources
- Minimum thermal resistance of the existing wall: $R \geq 0.4 \text{ m}^2\text{K/W}$
- Indoor climate with normal moisture load according to WTA-guideline 6-2-14 [18] or lower of not air conditioned residential or residential-like buildings.
- Mean annual temperature of the outside air: $\geq 7^\circ \text{C}$
- Infiltration of the room air behind the interior insulation is excluded
- Maximum improvement of the thermal resistance R by:
 - $2.5 \text{ m}^2\text{K/W}$ – with well absorbent substrate or with weakly absorbent substrate in combination with a moisture variable vapour barrier
 - $2.0 \text{ m}^2\text{K/W}$ – with weakly-absorbent substrate
- The existing wall and the internal insulation layer must be moisture resistant (equilibrium moisture content up to 95 % RH).

There are other restrictions for the calculation method of DIN 4108-3 or EN 13788: It is not applicable for "interior insulation with $R > 1.0 \text{ m}^2\cdot\text{K}/\text{W}$ on single-shell exterior walls with distinct sorptive and capillary properties". Note: If the method is nevertheless applied and the construction can be verified with it, this means that it is functional without the sorptive and capillary properties. If it cannot be verified, a method must be used that takes these properties into account.

The verification according to WTA Guideline 6-4-16 is carried out using a diagram. Based on the existing construction (A-value) and the planned thermal insulation improvement (ΔR_i), the minimum required s_d -value of the entire interior insulation system is determined.

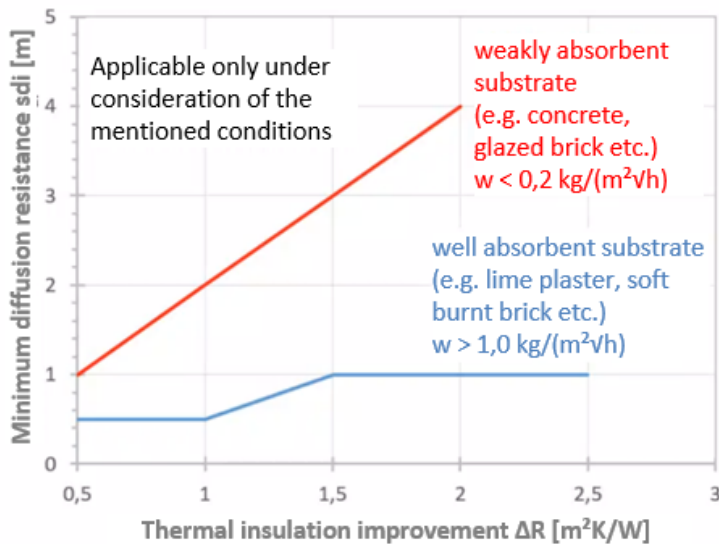

Fig. 12 Minimum required s_d -value of the interior insulation system (thermal insulation improvement ΔR_i includes all components of the insulation system) for different absorbent substrate (source: WTA-guideline 6-4-16 [4]).

The application of the simplified verification method must be justified and documented. This verification only applies to the undisturbed wall area. The thermal bridges must be examined separately. The functional principal of the capillary-active, vapour permeable interior insulation systems is not covered by the simplified, existing procedure.

An example of a simplified verification is shown in Annex A III.

In this simplified procedure, the vapour permeable, capillary-active insulation materials still had to be excluded, as no evaluation of the functionality is available. In order to fulfil this gap, the current In2EuroBuild project has extended the procedure of the simplified verification (2nd stage) for the classification of the capillary-active, vapour permeable insulation systems as an additional assessment option.

5.3 Extension of the simplified verification – classification of vapour permeable, capillary-active insulation systems

In vapour permeable, capillary-active insulation systems, two counteracting moisture transport processes take effect during the cold climate period. The diffusion transport from the room side towards cold outdoor side leads the moisture entry into the insulation system and an increase of moisture level on its cold side. From about 80 % RH onwards, liquid water transport can begin, which leads the moisture back transport towards the room and slows down or even completely

compensates a further moisture accumulate at the cold side. The moisture level on the cold side of the insulation material is also influenced by other factors, especially:

- The water vapour diffusion resistance of the insulation system and the existing wall
- The absorbency of the interior surface of the existing wall
- The sorption capacity of the substrate
- The sorption capacity of the adhesive and insulation material
- As well as the outdoor and indoor climatic conditions

An adequate consideration of all these affecting parameters is not possible within the framework of a simplified verification. In order to classify the vapour permeable, capillary-active materials and thus enable a qualitative comparison of different insulation systems, the application requirements are therefore adapted from WTA guideline 6-4-16 [4] as for the general simplified verification, with only minor adjustments. In this way, a large part of the remaining affecting parameters can already be “eliminated”. The application requirements from the former section 5.2 therefore also apply here with the following differences:

- For weekly absorbent substrates with $A < 0.2 \text{ kg}/(\text{m}^2 \cdot \sqrt{\text{h}})$, individual assessment is required.
- The simplified verification only applies to well or moderately absorbent substrates. For these, a maximum improvement of the thermal resistance R by $2.5 \text{ m}^2 \cdot \text{K}/\text{W}$ applies without further differentiation.
- The existing wall and all components of the internal insulation system to be applied must be suitable for the moisture conditions that may occur respectively.

Although the capillary-active interior insulation is often used in areas where drying towards room is required, e.g. due to driving rain absorption, this situation cannot be integrated into the simplified verification. The specific driving rain load and the climate related drying potential differ so significantly depending on the location and influence the behaviour of the entire component so strongly that no generally valid approvals would have been possible for practical applications. Such complex application therefore remains required the individual verification.

The vapour permeable, capillary-active interior insulation should preferably be used in the room climates with low or normal occupancy, as the moisture entry can be very high in other uses. Therefore, only these occupancies are taken into account for the simplified verification and classification.

Furthermore, a distinction is made as to whether the substrate is able to counteract a moisture increase at the interface between the insulation and the existing surface to a lesser or greater extent through its own absorbency. For this purpose, a distinction is made between surfaces with an A -value of at least $0.2 \text{ kg}/\text{m}^2 \cdot \sqrt{\text{h}}$ and those with at least $1.0 \text{ kg}/\text{m}^2 \cdot \sqrt{\text{h}}$. The first group also includes less absorbent mineral surfaces such as most concretes or cementitious renders, but not surfaces with very tight concretes, sealed by paints, tiles or plastics. The second group covers more absorbent plasters and most masonry where the old interior plaster or coating has been removed.

The classification applies to three application areas for which vapour permeable, capillary-active insulation materials are particularly suitable and provides for two function categories respectively depending on how strongly the moisture increase can be retarded. The application areas are summarized in the following table according to the above description:

Tab. 5 Application area for the simplified verification of vapour permeable, capillary-active insulation materials or systems.

	Application area		
	I	II	III
Moisture load acc. to WTA 6-2	low	low	normal
Absorbency of the existing wall surface (comparable to WTA 6-4)	Well absorbent $A \geq 1.0 \text{ kg/m}^2\text{v/h}$	Moderate absorb. $A \geq 0.2 \text{ kg/m}^2\text{v/h}$	Well absorbent $A \geq 1.0 \text{ kg/m}^2\text{v/h}$

The classification is based on the moisture level that reaches on the cold side of the insulation in the above-mentioned application area. If the insulation material or the system strongly counteracts the increase of the moisture level, so that the relative humidity can be limited to less than 95 % RH in interaction with the substrate, the system can be used in the specified application area without restrictions – it thus meets the category A: *generally functional*. Below 95 % RH, no other problems are to be expected apart from mould, which can be prevented by a largely flat bonding. Wood and pure gypsum materials (without natural fibre components) can also tolerate these conditions at low temperatures according to WTA guideline 6-5 [12], so that frost damage is also not to be feared if the minimum thermal resistant of the existing wall is not maintained. If the moisture level exceeds 95 % RH, but remains within the range of max. 99 % RH, the insulation material or the system can be classified in category B: *functional with moisture resistance*. If even higher moisture conditions are reached, condensation cannot be excluded and a general approval is not possible.

Tab. 6 Classification for the respective application area

	Classification Category		
	A	B	[-]
Max. RH at the interface between insulation and wall during winter	$\leq 95 \text{ \% RH}$	$\leq 99 \text{ \% RH}$	$> 99 \text{ \% RH}$
Requirements on the substrate material and the insulation system	No (resistant up to 95 % RH)	Moisture, frost and rot resistant up to 99 % RH	Individual design according to WTA 6-5

The characteristic values to be determined for the classification of the insulation materials and the boundary conditions for the simulations to be carried out are described in Annex A IV .

The functional suitability of vapour permeable insulation materials with capillary-active properties varies product-specifically. Therefore, a standardized classification according to the type of material is not applicable.

In this project, investigations were carried out for selected vapour permeable insulation materials with more or less pronounced capillary properties. In Annex A IV the results of these evaluations with assignment to the corresponding application areas is presented.

5.4 Verification by hygrothermal simulation

For all constructions not to be classified in the above-described categories A and B, proof of functionality by means of a hygrothermal simulation according to DIN 4108-3 is required. This can be provided referring to simulation studies / results already carried out or by an individual assessment.

Two software applications are currently established on the German market for individual assessment – WUFI® and DELPHIN.

The WUFI® software was developed at the Fraunhofer Institute for Building Physics (IBP) in Holzkirchen [22]. WUFI provides for the coupled calculation of transient heat and moisture transport through building components. Over the years, WUFI® has been experimentally validated in many cases and complies with the requirements of the European standard DIN EN 15026 [23] as well as other standards. The software is available in different versions, in addition to the calculation of the one-dimensional, also allow the assessment of two-dimensional issues (WUFI®-2D) or even the whole building behaviour (WUFI® Plus).

The DELPHIN 6 software package developed at the Institute of Building Climatology at the TU Dresden is a numerical simulation program for the coupled transport of heat, moisture, air and salt in building structures and is also used worldwide in research institutes and engineering practices [28]. The consideration of any climate and use-age boundary conditions provides information on numerous aspects such as rising damp, the influence of radiation, materials, driving rain or installation moisture. It can also be used to calculate 3D details such as steel girders or corbels. The graphical output shows all the relevant variables in terms of building physics, can indicate the causes of possible structural damage and provide the verification of the applicability and the safety of a structure.

The verification of interior insulation systems by means of hygrothermal simulations is described in the WTA-guideline 6-5-14 [12]. In the simulations, a distinction is mainly made between steady-state (constant indoor and outdoor climatic conditions) and transient (real data sets with changing indoor and outdoor climatic conditions) as well as one-dimensional and multi-dimensional.

Procedure:

- Proof of the current condition

Before investigating one or more insulation systems, it is often worthwhile to carry out a hygrothermal calculation of the current conditions of the existing structure with the specific boundary parameters. The driving rain values implemented in the existing climate files of the reference locations usually do not correspond to the loads at the individual, mostly urban location, and can be significantly underestimated. They should be, therefore, calibrated on the basis of the moisture behaviour of the existing wall. Reference calculations are quite helpful for that. Alternatively, driving rain measurements can be carried out on the facades to be concerned. The first calculation serves as a reference calculation for the following verifications with selected interior insulation systems. With the reference simulation, it should be possible to represent the existing building physics condition of the construction with the existing boundary conditions, i.e. if mould has formed on the existing construction, it should also be possible to reproduce this with the simulation results. Within the framework of the insulation concept, these calculations are usually carried out as one-dimensional simulations for the undisturbed wall cross-section.

The calculation period must be selected so that the dynamic hygrothermal equilibrium state is reached. For the maximum annual difference, 1 % of the total water content can be used in accordance with Annex D of DIN 4108-3 [5]

- Verification of the interior insulated construction

Based on the reference calculation and the preliminary investigations, suitable insulation systems for the planned use are analysed and evaluated. The following properties are, in particular, taken into account:

- thermal conductivity
- vapour diffusion
- liquid water conductivity and drying potential
- costs

The simulations can also be used to investigate how the selected insulation systems can manage an existing moisture load in the masonry.

The verification is carried out by means of hygrothermal simulation of the undisturbed existing wall with the selected insulation systems, whereby the simulations are carried out with transient boundary conditions, i.e. using a real climate data set for the location or neighbourhood. If necessary, variations with and without rain influence, with and without initial moisture content of the existing structure, with varying boundary conditions for different indoor climates or for various insulation material variants are carried out. The exact verification procedure will be described later.

- Recommendation of one or more insulation systems

As a result of these investigations, the client can be provided with verification for the selected insulation system, taking into account all specified requirements, or a comparison of the insulation systems can be produced, from which a recommendation for well-suited insulation systems can result.

- Further procedure

Only when the basic hygrothermal functionality of the one-dimensional construction with interior insulation can be proven and the choice of a suitable system has been made, is a two-dimensional investigation of structural connection details recommended. The selection and procedure is described in the next chapter 6.

Performance of a hygrothermal simulation

Generally the existing WTA guideline 6-1 to 6-5 is referenced, in which information on materials, climatic boundary conditions, heat and moisture transfer coefficients, simulation duration, output, evaluation criteria and approached, etc. are described.

Within the scope of this practical guideline, an overview of the most important parameters, boundary conditions and evaluation criteria is presented. A summary of these data can be found in Appendix A VI .

5.5 Simulation tables for typical applications / approvals by manufacturers

Since not every planner is able to perform hygrothermal simulations by himself, simulation studies for different insulation types and common building situations are available, which have been carried out either within the framework of earlier research projects or by individual manufacturers. Such results can also be used for the design (deemed to satisfy constructions).

6 Dimensioning / execution of connection details

In the planning phase, before the actual detailed planning, the question usually arises as to how much space is needed for soffit and flank insulation, for example. It is helpful if at least the most important connections can be roughly dimensioned in advance.

6.1 General dimensioning recommendations

Once the basic energy renovation concept has been clarified, including ensuring protection against driving rain, determining an insulation system and the insulation thicknesses to be used, the focus is on the detailed planning.

Based on many years of experience with interior insulation measures, the following rough dimensioning recommendations can be given for preliminary planning. In the course of the implementation planning, however, an adjustment is usually made again for the concrete object according to the on-site conditions and the condition and properties of the existing construction.

6.1.1 Window reveal/ window lintel

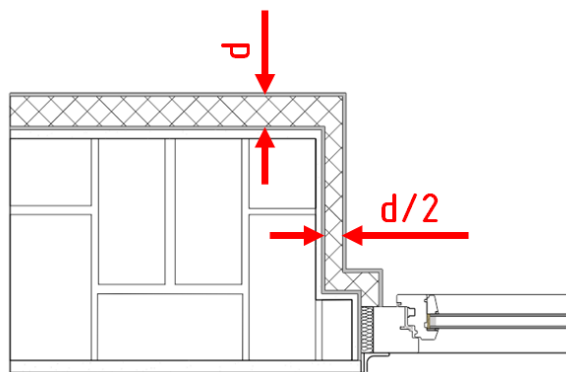

Fig. 13 Recommendation for pre-dimensioning of an internally insulated window reveal

In soffit and lintel areas of existing buildings, there is usually only little space available for insulation. In many cases it is sufficient to use about half of the standard insulation thickness of the interior insulation for the reveal (with the same insulation properties). If insulation with a lower thermal conductivity is used in this area, the insulation thickness of the reveal insulation can be reduced if necessary.

In this context, special attention must be paid to the formation of the joint between the masonry and the frame. A continuous insulation level must be created between this joint and the reveal insulation. This transition is a typical weak point in a renovation measure.

6.1.2 Existing interior wall

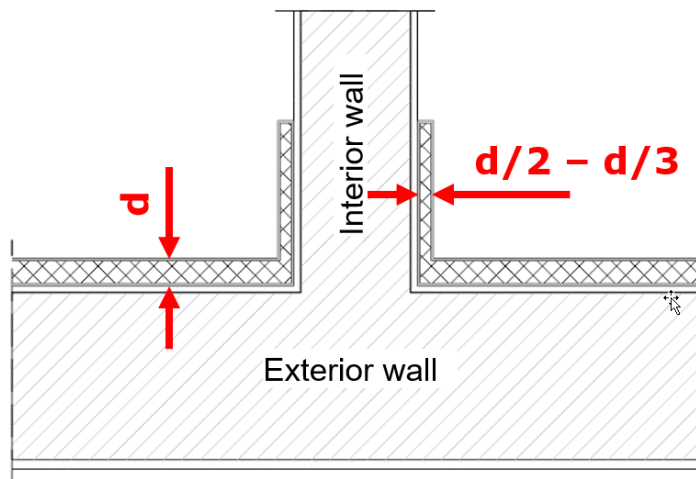

Fig. 14 Recommendation for pre-dimensioning of an integrating interior wall

In order to reduce thermal bridges, it makes sense to optimise the corner areas on connecting solid interior walls. Whether this is necessary depends above all on the thermal resistance R (see Chap. 4.2.2) of the existing wall and the thickness of the exterior and interior wall. The less favourable the energy quality of the existing exterior wall, the greater the probability that the minimum thermal insulation in the wall corner will not be met with the existing wall and then also with the application of interior insulation. If the minimum thermal insulation of the existing exterior wall is well maintained, flank insulation is usually not necessary.

The thinner the existing exterior wall and the thicker the connecting interior wall, the greater the probability that the installation of flank insulation will be necessary in this area. With the same wall materials, it can be roughly assumed that it will only be necessary if the interior wall is more than half the thickness of the exterior wall.

In many cases, it is sufficient if approx. one third to one half of the standard insulation thickness of the interior insulation is used for the flank insulation (with the same insulation properties). If insulation with a lower thermal conductivity is used in this area, the insulation thickness of the flank insulation can be reduced if necessary. As an installation length for the flank insulation, 30-40 cm is usually sufficient. This can be done in the form of rectangular or wedge-shaped board insulation or an insulating plaster. In the meantime, special "heat-conducting sheets" are also available, which are attached as perforated aluminium sheets with a thin insulation layer on the back at the interior wall connection and are plastered in. This connection is thus made without disturbing steps or wedges.



Fig. 15 Examples of the design of flank insulation: as a board (left, source: www.calsitherm.de), as an insulation wedge (centre, source: www.multipor.de) or perforated aluminium sheet with a thin insulation layer on the back (right, manufacturer: www.caparol.de).

6.1.3 Massive ceiling

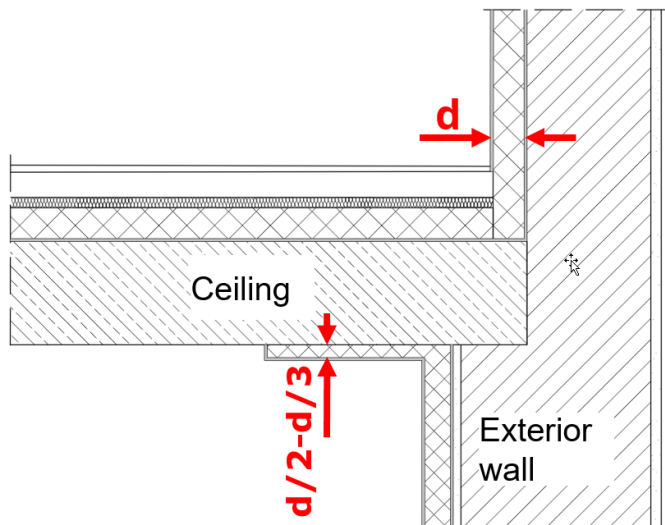

Fig. 16 Recommendation for pre-dimensioning of an integrating solid storey ceiling

To reduce thermal bridges, it is often necessary to optimise the corner areas of connecting solid existing floor slabs (e.g. reinforced concrete slabs), at least in the area of an external corner, because the embedment depth is large or there is no slab edge insulation on the face side. In the normal edge area, flank insulation is not always necessary.

In many cases, it is sufficient if approx. one third to one half of the standard insulation thickness of the interior insulation is used for the flank insulation (with the same insulation properties). If insulation with a lower thermal conductivity is used in this area, the insulation thickness of the flank insulation can be reduced if necessary. As an installation length for the flank insulation, 30-40 cm are usually sufficient. The type of flank insulation can be carried out in the same way as for the interior walls. However, the use of heat-conducting sheets only makes sense if no suspended ceilings are installed.

6.2 Typical connection details

In the detailed planning, care should be taken to minimise penetrations through the insulation level. A continuous airtight level in the thermal envelope must be ensured in order to avoid the risk of convective vapour intrusion behind the insulation level.

An awareness of the functional levels in constructions must be developed among those involved in planning in order to place the appropriate materials in the right place.

First, typical connection details for the specific building (such as windows, ceilings, balconies) are recorded, and the general location of layers in connection areas and their attachment to the substructure are determined.

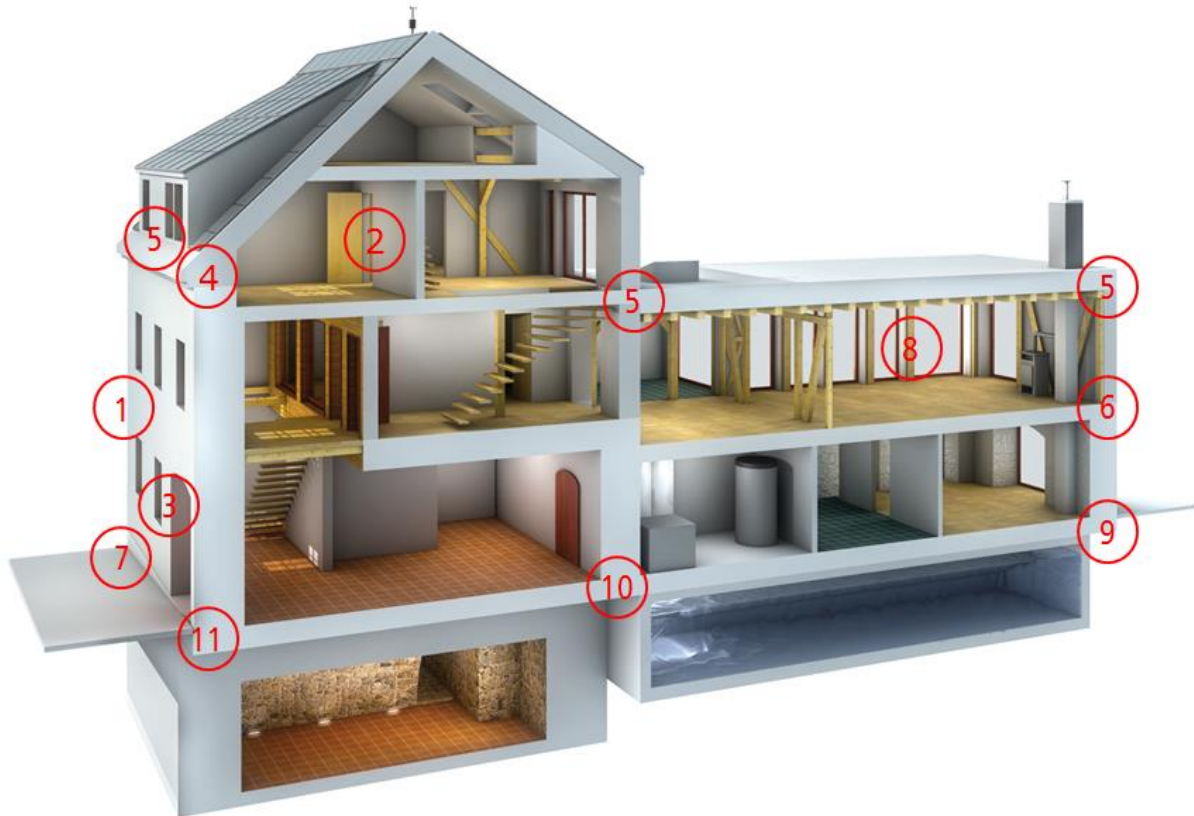

Fig. 17 Illustration of common critical connection details in buildings with interior insulation
(Source: Christian Conrad/ Dr. Holger Neuhaus)

The appendix A IX describes the principles of frequent connection details for different installation situations.

Common thermal bridges are:

- 1 Outside corners of walls
- 2 Integrating interior walls
- 3 Window lintel, reveal, parapet, also roller shutter
- 4 Connection of jamb to roof construction
- 5 Verge and other roof connections
- 6 Integrating storey ceilings
- 7 Balcony connections
- 8 Pillar
- 9 Connection of external wall to floor slab/ KG ceiling
- 10 Interior walls on KG ceiling
- 11 Base areas
- 12 Penetrations through the thermal envelope (steel girders, reinforced concrete under and overlays, ...)

6.3 Selection criteria for the detailed design

On the basis of the typical critical detail points, the thermal bridges occurring on the specific building can be examined. Cooperation between the architect/planner and building physicist is very important, especially if the executed connection details cannot be clearly recorded. In the case of many construction connections, additional calculations can be dispensed with due to the simple and straightforward execution or with a well thought-out planning of the execution details or in

combination with execution instructions by the building physicist, and recourse can be made to existing suitable detail executions. This means that thermal bridge calculations can be reduced to a minimum.

If possible, the critical case should be selected from the connection details to be considered for the different connection areas, for which the detailed design is then carried out.

For example, in the case of integrating solid existing walls, this means that the internal wall with the greatest wall thickness and simultaneously low external wall thickness becomes the most critical. This can then become the design case for all similar connections. In this way, there is clarity for the execution on the construction site with the simplest and most uniform design specifications possible.

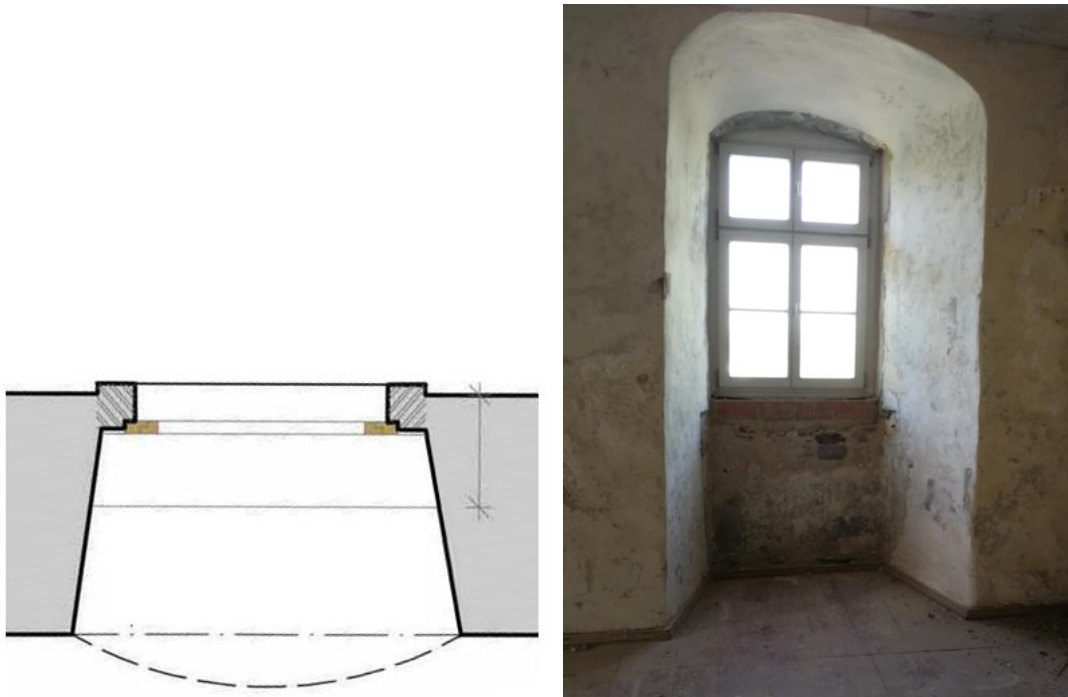

Fig. 18 Hydrothermally critical window connection: large wall thickness and window position close to the façade, window surround made of natural stone

When dimensioning windows, it should be noted that the further the window level is from the insulated wall level, the more critical the connection situation becomes. A position of the window almost flush with the façade in combination with a very large wall thickness therefore represents the worst case. In addition, cross-sectional weakening in the window connection area or material changes (e.g. steel beams in the lintel area) must also be considered.

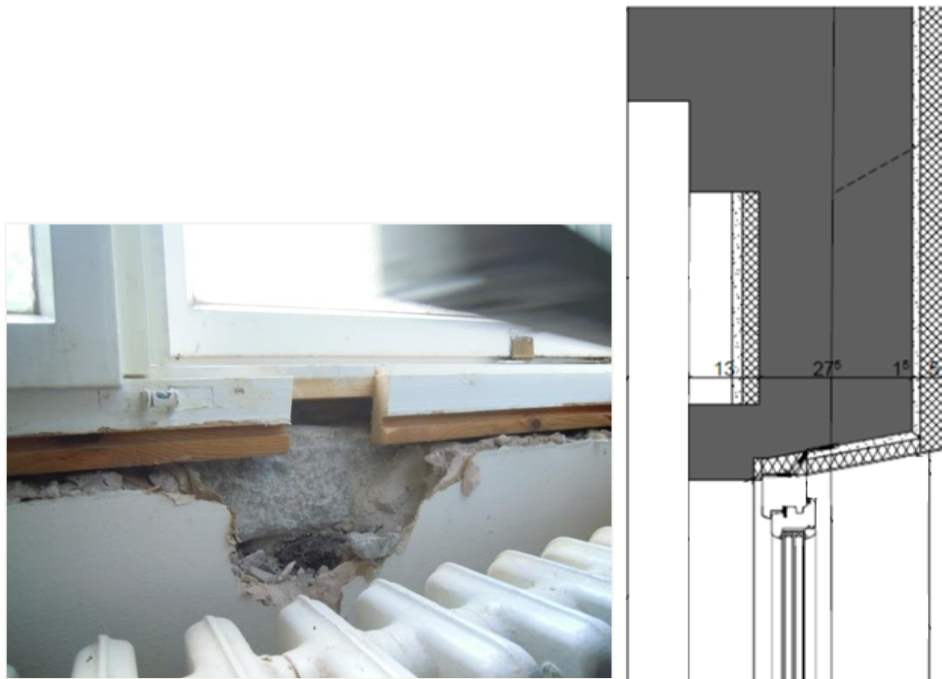

Fig. 19 Hygrothermally critical window connections; left: continuous natural stone window sill from the outside to the inside, right: low wall thickness with additional cross-sectional weakening in the lintel plane.

Furthermore, special constructional features of the building, such as penetrations through the thermal envelope, must be taken into account. In this context, special attention should be paid to steel girders or reinforced concrete beams or joists with an integration into the external wall to be insulated or similar (cf. Fig. 20 and Fig. 21).



Fig. 20 Example of a reinforced concrete overlay in the ceiling to the unheated loft



Fig. 21 Steel frame construction in the thermal plane with integration into the reinforced concrete jamb

6.4 Constructive tips for interior insulation measures

6.4.1 Load fastening

Penetrations through fasteners are a weak point in an internally insulated construction, as they are located in the potential condensation plane. Therefore, penetrations should be avoided if possible, but this is rarely feasible.

Light loads, such as pictures, can be fixed to the existing wall with insulation screw anchors. For medium loads, special mounting elements without mechanical fastening are available, e.g. mounting cylinders or mounting blocks made of hard foam. For higher loads, mounting elements with mechanical fastening can be used (Fig. 22).



Fig. 22 Examples of fastening loads in internally insulated structures: on the left spiral anchors for light loads (source: www.ejot.de), in the middle two compression-resistant mounting elements for medium loads (source: www.dosteba.de), on the right heavy-duty anchors with thermal decoupling for heavier loads (source: www.dosteba.de).

6.4.2 Sockets

Socket outlets are a weak point in an internally insulated construction because they are located in the potential condensation plane. Therefore, placement on these walls should be avoided as far as possible. If placement is necessary and there is not enough space for an insulation layer between the bottom of the socket and the existing wall (between 3 and 4 cm depending on the insulation material), the socket must be insulated around.

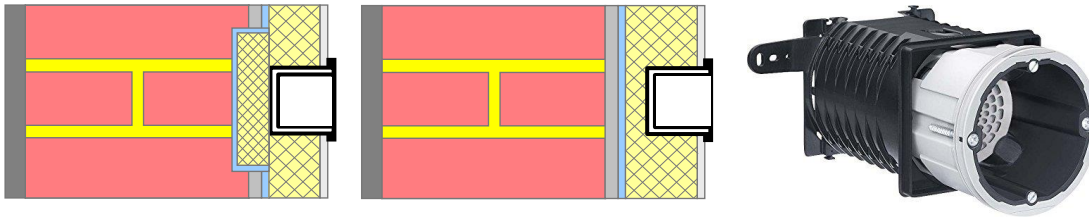

Fig. 23 Re-insulation of a socket in an internally insulated exterior wall (left), sufficient remaining insulation thickness in the standard insulation (middle) or use of a special insulation box(right, source: www.kaiser-elektro.de)

For this purpose, a recess is made in the existing wall with the required depth and the necessary projection before applying the interior insulation. This area is filled with an insulation board over the entire surface (left in the Fig. 23). The interior insulation can then be carried out as planned. Special attention must be paid here to the airtight design of the boxes, switch inserts and cable routing.

This intervention can be very time-consuming. Alternatively, special insulation boxes can be used, which have a layer of insulation on the back and are specially designed for this application (Fig. 23 right).

6.4.3 Building services

In most cases, the complete energy refurbishment of a building is accompanied by the renewal of the systems engineering. If the existing system technology or at least parts of it are to be used further, these should be recorded with their existing components as part of the inventory analysis. The type and location of heating as well as the presence of a ventilation system can influence the effect of a planned interior insulation measure and thus limit or expand the selection of potential insulation materials. For the dimensioning of insulation systems, for example, the presence of a ventilation system means lower indoor air humidity and thus generally more favourable conditions. Likewise, air heating systems mean a more even mixing of the room air and balanced temperature conditions on the inner wall surface.

In addition to the room-climatic effects of heating and ventilation systems, their constructive integration is also of interest. Possible weak points must be identified and included in the planning. For example, both heating and ventilation systems cause penetrations of the exterior wall. Examples of this are radiator fixings and pipe penetrations (outside air intake). On the one hand, these potential weak points can lead to the creation of constructive thermal bridges in the wall cross-section; on the other hand, they can break through the airtightness level and cause convective moisture entry from the room air into the wall. The last aspect is associated with a high potential for damage, especially in systems with a vapour barrier.

Furthermore, it should be noted that water-bearing pipes should never be installed on the outside of the insulation level, as there is a high risk of frost here.

6.4.4 Wood beam ceilings

In the area of the ceiling supports, the wooden beams penetrate the level of the interior insulation and form a thermal bridge. The joist end becomes somewhat colder and more humid than before. Therefore, the question arises whether the joist ends can become so damp through the interior insulation that they are damaged. In the meantime, this question has been examined in more detail in many research projects (see [24], [25], [26]), and the results were predominantly uncritical. The following aspects should be considered:

- If there is already damage to joist ends, these and their causes must be repaired. If this is done inadequately, there is a risk that the damage will soon reappear.

- Penetrating driving rain poses the greatest danger. Sufficient driving rain resistance must therefore be provided (reference to chapters 3.4 and [12]).
- Even without damage, it is recommended to check the joist ends selectively at vulnerable points, e.g. in the area of water-bearing pipes, roof pipes and at the building corner of the weather side. If an endoscope is not sufficient for this, the ceiling must be opened.

In the event that damage is present, a wood preservation surveyor should be used.

If possible, it is advisable to insulate throughout, i.e. to insulate not only in the area of the room surfaces that will be visible later, but also on the exterior wall at the ceiling level. In addition to lower thermal energy losses, this approach can also prevent mould growth in the ceiling area between the joists. Mould growth is to be feared there if greater insulation thicknesses are applied (Fig. 24 right). If, for example, 10 cm of interior insulation or more is only applied in the area of the room, the uninsulated existing surface in the immediate area above the ceiling cladding can cool down to such an extent that mould develops there, especially if the masonry is thin.

In case of uncertainties, the joist end area can also be investigated very well by two-dimensional, hygrothermal simulations [27].

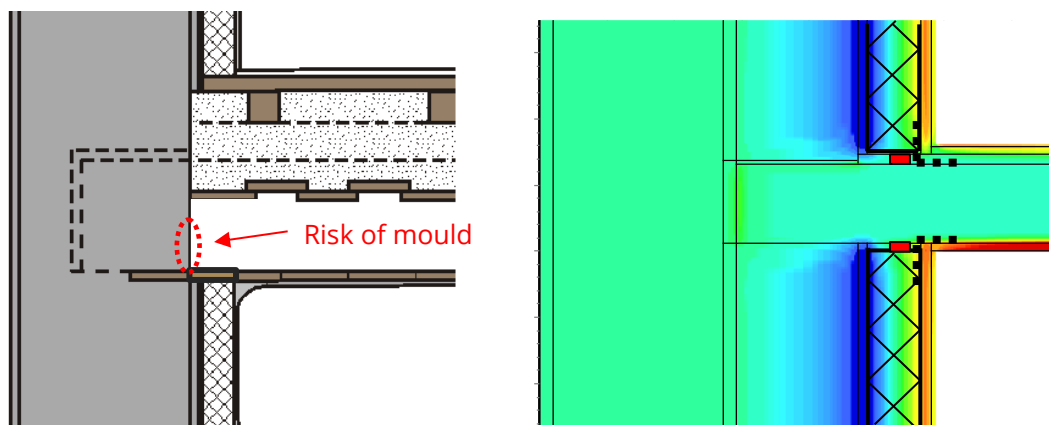

Fig. 24 On the left: area at risk of mould if insulation is not continuous, on the right, two types of joist end sealing with plaster connection tape (black) or stuffing wool/hemp strips (red); the picture on the right shows an example of the distribution of relative humidity in winter (Software: DELPHIN6)

It is recommended to seal the joist supports in a convection-inhibiting manner (see for it WTA-guideline 8-14 [29]). This means that between the interior insulation and the ceiling joists, for example, a mortar coating on a back-filled joint (stuffing wool, hemp strips) is applied (Fig. 24 left). If the surfaces of the building components are even, pre-compressed sealing tapes are also possible. Assembly foam is unsuitable. Wide cracks in the beams must be closed, e.g. by chipping or wooden dowels or inserting suitable, dry pieces of wood. Synthetic joint sealants are not recommended. A convection-tight connection by closing cracks of small width is not necessary under normal climatic conditions to protect the beam heads.

When installing new beams, leave an air layer of at least 20 to 30 mm in front of the end timber. In the beam support, insulation can be fitted around the beam head and in front of the face timber, but this must be open to diffusion.

To prevent any moisture from the masonry from penetrating into the beam head, a barrier layer should be placed under the beam head. This barrier layer can only be applied to existing buildings with greater effort and is only necessary if there is a corresponding moisture load. In permanently dry masonry it is not necessary. If it is not possible to prevent moisture from entering the beam

head and the wood used is not very durable (e.g. spruce, fir), the beam head should be treated with an approved wood preservative using a surface treatment or a deep-penetrating treatment, e.g. by drilling holes. If there is still a risk of excessive moisture exposure, various methods can be used to decouple the wooden ceiling beam (WTA-guideline 8-14 [29]) e.g. steel, GRP, bracket, Zwickau beam shoe, under/overlay, beta method, under-wall/house-in-house].

6.5 Hygrothermal simulation of connection details

For most buildings, the focus is on connection details for common connections, i.e. mainly window, ceiling and wall connections.

For some standard component connections, detail drawings and their evaluation are described in the appendix A VIII .

7 Literature

- [1] Arbeiter, K. (2014). Innendämmung - Auswahl, Konstruktion, Ausführung. Köln: Rudolf Müller Publishing.
- [2] Fachverband Innendämmung e.V. (2016). Praxis-Handbuch Innendämmung: Planung - Konstruktion - Details - Beispiele. Köln: Verlagsgesellschaft Rudolf Müller GmbH & Co.
- [3] Innenwärmedämmung - Merkblatt der Berufsverbände. (2016). Innenwärmedämmung - Merkblatt für Planung und Anwendung im Bestand und Neubau. Stuttgart: Fachverband der Stuckateure für Ausbau und Fassade Baden-Württemberg, Schweizerischer Maler- und Gip-sunternehmer-Verband.
- [4] WTA Guideline 6-4. (2016). Innendämmung nach WTA I: Planungsleitfaden. München: Fraunhofer IRB-Verlag
- [5] DIN 4108-3. (2018). Wärmeschutz und Energie-Einsparung in Gebäuden – Teil 3: Klimabe-dingter Feuchteschutz – Anforderungen, Berechnungsverfahren und Hinweise für Planung und Ausführung. Berlin: DIN Deutsches Institut für Normung e.V.
- [6] WTA Guideline 6-15. (2013). Technische Trocknung an durchfeuchteten Bauteilen, Teil 1: Grundlagen. München: Fraunhofer IRB-Verlag.
- [7] WTA Guideline 6-16. (2019). Technische Trocknung an durchfeuchteten Bauteilen, Teil 2: Pla-nung, Ausführung und Kontrolle. München: Fraunhofer IRB-Verlag.
- [8] DIN 18533-1. (2017). Abdichtung von erdberührten Bauteilen - Teil 1: Anforderungen, Pla-nungs- und Ausführungsgrundsätze. Berlin: DIN Deutsches Institut für Normung e.V.
- [9] WTA Guideline 3-13. (2019). Salzreduzierung an porösen und mineralischen Baustoffen mit-tels Kompressen. München: Fraunhofer IRB-Verlag
- [10] WTA Guideline 2-9. (2020). Sanierputzsysteme. München: Fraunhofer IRB Verlag.
- [11] Schöner, Hevesi-Toth, Zirkelbach, & Fitz. (2018). In-Situ Messgerät zur Bestimmung der Schlagregenintensität. Fraunhofer IRB-Verlag
- [12] WTA Guideline 6-5. (2014). Innendämmung nach WTA II - Nachweis von Innendämmsyste-men mittels numerischer Berechnungsverfahren. München: Fraunhofer IRB Verlag.
- [13] WTA Guideline 3-17. (2010). Hydrophobierende Imprägnierung von mineralischen Baustof-fen, Stuttgart: Fraunhofer IRB-Verlag
- [14] WTA Guideline 2-4-14. (2014). Beurteilung und Instandsetzung gerissener Putze an Fassaden. München: Fraunhofer IRB-Verlag.
- [15] <http://altbaukonstruktionen.de>. (2009). Erfassung regionaltypischer Materialien im Gebäu-debestand mit Bezug auf die Baualtersklasse und Ableitung typischer Bauteilaufbauten. Ret-rieved from ZUB Kassel.
- [16] <https://www.masea-ensan.de>. (2007). Materialdatensammlung für die energetische Altbau-sanierung. Retrieved from Fraunhofer IBP; IBK TU Dresden; ZUB Kassel
- [17] DIN 4108-2. (2013). Wärmeschutz und Energie-Einsparung in Gebäuden – Teil 2: Mindestan-forderungen an den Wärmeschutz. Berlin: DIN Deutsches Institut für Normung e. V.
- [18] WTA Guideline 6-2. (2014). Simulation wärme- und feuchtetechnischer Prozesse. München: Fraunhofer IRB-Verlag
- [19] WTA Guideline 8-5. (2008) Fachwerkinstandsetzung nach WTA V: Innendämmsysteme, Mün-chen: Fraunhofer IRB Verlag
- [20] Engelhardt, Antretter, & et. al. (2019). Energieeffizienzsteigerung durch Innendämmsysteme - Anwendungsbereiche, Chancen und Grenzen
- [21] DIN 68800-2. (2012). Holzschutz - Teil 2: Vorbeugende bauliche Maßnahmen im Hochbau. Berlin: DIN Deutsches Institut für Normung e.V.

- [22] Künzel, H. (1994). Verfahren zur ein- und zweidimensionalen Berechnung des gekoppelten Wärme- und Feuchtetransports in Bauteilen mit einfachen Kennwerten. Dissertation, Fraunhofer IRB-Verlag
- [23] EN 15026. (2007). Hygrothermal performance of building components and building elements – Assessment of moisture transfer by numerical simulation. Berlin: Beuth Verlag
- [24] <https://www.renofase.be/> am 14.7.2022
- [25] <https://www.ribuilt.eu/> am 14.7.2022
- [26] EnOB-Bewertungsverfahren für Bestandsgebäude mit Holzbalkendecken, Förderkennzeichen: 0329663O-P. (2016). Final report (German)
- [27] Ruisinger U, Kautsch P. Comparison of hygrothermal 2D- and 3D-simulation results with measurements from a test house, E3S Web of Conferences 172, 08004 (2020), <https://doi.org/10.1051/e3sconf/202017208004>
- [28] www.bauklimatik-dresden.de on 14.7.2022
- [29] WTA Guideline 8-14. (2014). Ertüchtigung von Holzbalkendecken nach WTA II: Balkenköpfe in Außenwänden. München: Fraunhofer IRB-Verlag
- [30] WTA Guideline 4-9. (2019). Nachträgliches Abdichten und Instandsetzen von Gebäudesockeln. München: Fraunhofer IRB-Verlag
- [31] WTA Guideline 4-7. (2015). Nachträgliche mechanische Horizontalsperre. München: Fraunhofer IRB-Verlag
- [32] WTA Guideline 4-4. (2004). Mauerwerksinjektion gegen kapillare Feuchtigkeit. München: Fraunhofer IRB-Verlag
- [33] Binder A, Zirkelbach D, Künzel H, Fitz C. Praxisgerechte Beurteilung und Quantifizierung der Kapillaraktivität von Innendämmmaterialien. IBP-Mitteilung 514, 38 (2011), Fraunhofer-Institut für Bauphysik
- [34] Hirsch H, Heyn R, Kloseiko P. (2020). Capillary condensation experiment for inverse modeling of porous building materials, <http://doi.org/10.1051/e3sconf/202017217003>, E3S Web of Conferences 172, 17003
- [35] WTA Guideline 6-3. (2005). Rechnerische Prognose des Schimmelwachstums. München: Fraunhofer IRB-Verlag
- [36] EN 13788. (2013). Hygrothermal performance of building components and building elements – Internal surface temperature to avoid critical surface humidity and interstitial condensation – Calculation methods. Berlin: DIN Deutsches Institut für Normung e.V.

A Appendix

A I Description of waterproofing systems

External vertical waterproofing in contact with the ground

Vertical sealing is ideally carried out on the outside. This solution is considered to be the preferred variant, as further moisture penetration into the exterior wall is avoided after drying and a drier existing wall insulates better.

Various waterproofing systems are available for this purpose in DIN 18533 [8], taking into account the aforementioned effects and requirements. These can be applied in the form of membranes or liquids.

If exterior walls in contact with the ground are exposed for a waterproofing measure, it is advisable to also install perimeter insulation, depending on the existing structure and planned use. This effectively combats the frequent problem of summer condensation in rooms in contact with the ground, increases comfort and reduces heat loss.



Fig. 25 Principle sketch for an external vertical seal (source: <https://www.remmers.com/de/bauwerksabdichtung/neubauabdichtung>) and example of a design

Inner vertical sealing

Vertical waterproofing from the inside is used when waterproofing from the outside is not possible or too costly. However, the existing walls remain damp.

The treatment of interior wall connections requires great care when sealing on the inside so that moisture cannot penetrate here either. Interior waterproofing can also be combined with interior insulation without any problems.

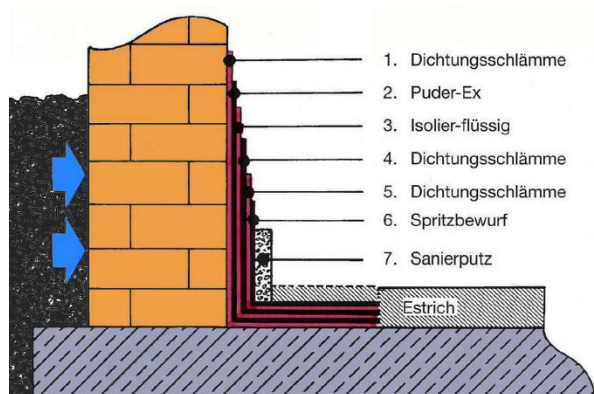

Fig. 26 Principle sketch for internal sealing (source: [https://www.ecodesign-beispiele.at/userfiles/images/133-Schema-20170816-4\(2\).jpg](https://www.ecodesign-beispiele.at/userfiles/images/133-Schema-20170816-4(2).jpg))

External waterproofing in the plinth area

An important component of the waterproofing system is the professional connection and the creation of an adequate base waterproofing above the vertical waterproofing in contact with the ground in order to prevent moisture ingress in the splash water area. For the execution of a professional plinth waterproofing, the WTA-guideline 4-9-19 [30] provides comprehensive planning and implementation recommendations for the subsequent sealing and repair of building and component plinths. It describes connection options to structural waterproofing and provides information on the necessary preliminary investigations, stresses, etc. for different types of execution. Sealing and overlap heights as well as possible materials to be used are also presented.

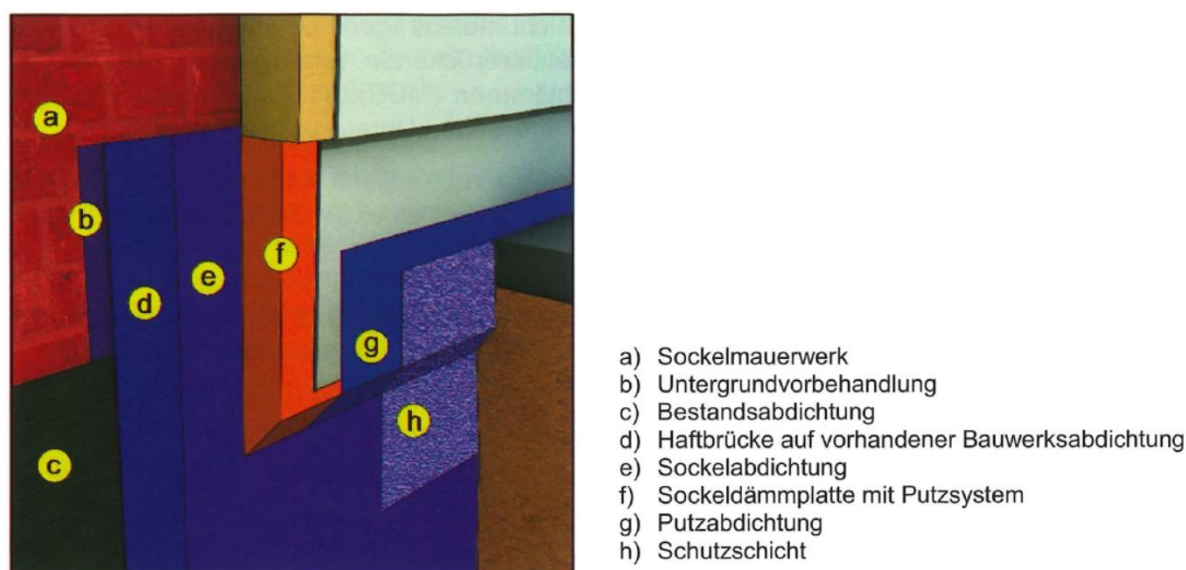

Fig. 27 Principle sketch for a plinth waterproofing (Source: WTA Guideline 4-9-19 [30])

Horizontal sealing in walls

In older existing buildings, there is often no horizontal barrier or one that no longer functions. To prevent or at least sufficiently reduce the rise of moisture in the masonry, a horizontal barrier is installed in the rising exterior walls and partly in interior walls, which is integrated into the vertical waterproofing and the surface waterproofing of the floor slab/ storey ceiling.

The following methods are available for the subsequent horizontal sealing of existing walls, which differ greatly in terms of effectiveness and effort (and thus costs). Depending on the existing situation, this measure is also carried out on interior walls. For the mechanical methods, the WTA-guideline 4-7-15 [31] provides extensive information on the application of the methods and the

choice of materials. Injection procedures are carried out in accordance with the WTA-guideline 4-4-04 [32].

- **Masonry replacement:** This is a time-consuming, traditional procedure in which the masonry, which is often contaminated with salt, is removed in sections (max. one metre!) in a strip one to three bricks high and replaced again with suitable materials after inserting a barrier membrane. The procedure offers a complete moisture barrier downwards, but it should only be carried out by experienced specialists, as it involves extensive intervention in the statics. It is only suitable for quarry stone walls to a very limited extent.
- **Masonry sawing method:** With this widespread method, the masonry joint is cut open section by section. Sealing foils or panels are then inserted into the joint and the barrier is wedged in place. The joint is sealed with mortar or swelling mortar. The quality of the workmanship can easily be checked visually. This method requires special tools and a continuous horizontal joint.
- **Drill core method:** Overlapping core holes with a diameter of eight to ten centimetres are drilled at intervals of six to eight centimetres. Dense mortar is poured or pressed into the drill holes. This interrupts the moisture transport. This method is also possible for very thick walls. However, it is very cost-intensive and is therefore rarely used.

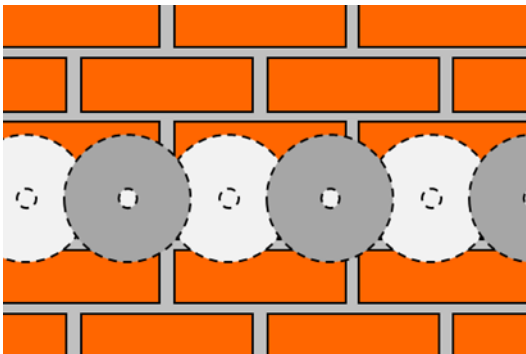

Fig. 28 Principle sketch of the drill core process

- **Sheet metal impact method:** The prerequisite for this method is a continuous bearing joint of at least 6 mm thickness. Corrugated steel sheets are driven into the joint with compressed air without opening the masonry. The sheets must overlap. This method is cheaper than the other methods. The success of the measure can be easily checked visually and results in a complete prevention of moisture transport. Cracking due to vibrations cannot be ruled out.
- **Injection method:** Here, injection fluid is injected deep and evenly into the wall via previously placed holes in the wall. The effectiveness of injection substances is based on different principles such as plugging, constriction, hydrophobisation or on combinations of constriction and hydrophobisation. It should be borne in mind that waterproofing systems based on injections do not completely stop rising damp, but only to a large extent (approx. 80-95%), which is, however, usually sufficient treatment. Depending on the system chosen, different requirements apply, which is why the manufacturer's specifications must be observed to a great extent.
- **Electrophysical methods:** Active electrical methods with application of electric current are assessed as "limited suitability" due to the high field strength required (https://de.wikipedia.org/wiki/Elektrophysikalische_Mauertrockenlegung). Electrical methods with electric fields to be generated with or without batteries ("magic boxes") are ineffective in construction practice. The success sometimes claimed in connection with such methods is usually based on the prescribed accompanying measures that reduce or completely eliminate the moisture load.

Horizontal surface sealing on the floor slab/floor slab

As part of the renovation planning, it must be checked to what extent a functioning surface sealing on the floor slab in contact with the ground or the lowest storey ceiling under the heated building area is available or necessary. In the case of rooms used for high-value purposes, a surface sealing level against the load of rising damp is necessary. In the case of basement ceilings, the necessity must be checked due to the moisture loads in the basement. The application of the surface waterproofing prevents moisture from reaching the floor above. Depending on the impact resistance, crack limitation or planned room use, different materials are available for this purpose, which can be laid in strips or applied in liquid form.

Overlaps must be provided between the corresponding installation positions to reliably prevent the entry of moisture.

A II Insulation systems investigated for hygrothermal behaviour (from EnEffID)

The following insulation systems were examined for their hygrothermal behaviour within the En-effID project [20]. The results can be used to make a preliminary selection of suitable systems for specific applications. The complete detailed evaluation of the individual variables can be found in the EneffID project report ([20]).

Non-hydrophobic wood fibre insulation

For the non-hydrophobic wood fibre insulation examined as an example, the following areas of application and limits resulted:

- The insulation system could be used up to a maximum thickness of 4 cm ($\lambda = 0.042$ W/mK) mostly without an additional vapour-barrier on the inner surface.
- An additional s_d - value of 2 m on the room side increases the maximum possible thickness to 6 cm - 8 cm (depending on the variant).
- This system is not suitable for extreme climatic locations (high driving rain load, low temperature, western orientation) e.g. Fichtelberg.
- Under normal room climate conditions according to DIN EN 15026 [23], all variants considered were functional at the locations Holzkirchen, Hamburg and Potsdam.
- It should be noted that for natural fibre insulation materials, the strict limit values of DIN 68800-2 [21] were used for evaluation.

Note: The results of the current research project In2EuroBuild show that many natural fibre insulation materials used as interior insulation can also tolerate significantly higher moisture conditions and are just as resistant or even more resistant than solid wood. If this resistance has been tested and confirmed for the respective material used, the application limits can be extended accordingly.

The complete results tables can be found in the EneffID project report in chapter 3.8.2 (from p. 208) as well as in the appendices referenced there.

Hydrophobic wood fibre insulation

The following areas of application and limits resulted for the hydrophobic wood fibre insulation examined as an example:

- The insulation system could be used at Potsdam and Hamburg as well as in Holzkirchen with a normal moisture load in the room up to a maximum thickness of 4 cm ($\lambda = 0.039$ W/mK) without an additional vapour-barrier layer on the inner surface.
- An additional s_d - value of 2 m on the room side significantly extends the range of applications.
- This system is not suitable for extreme climatic locations (high driving rain load, low temperature, western orientation) such as Fichtelberg.
- It should be noted that for natural fibre insulation materials, the strict limit values of DIN 68800-2 [21] were used for evaluation.

Note: The results of the current research project In2EuroBuild show that many natural fibre insulation materials used as interior insulation can also tolerate significantly higher moisture conditions and are just as resistant or even more resistant than solid wood. If this resistance has been tested and confirmed for the respective material used, the application limits can be extended accordingly.

The results tables can be found in the EneffID project report in chapter 3.8.2 (p. 208) as well as in the appendices referenced there.

Hemp fibre insulation board

The following areas of application and limitations resulted for the exemplary hemp fibre insulation examined:

- The hemp fibre insulation board can be used up to 4 cm thickness with a normal moisture load in the interior climate, mostly without an additional vapour-barrier on the interior surface.
- In particularly cold locations or locations with a heavy driving rain load, an additional vapour-barrier should be provided on the inside.
- For higher inner moisture loads in accordance to DIN EN 15026 [23] the use of moderate vapour retarders or vapour retarding layers is recommended, at least for greater insulation thicknesses.
- With an additional vapour-barrier with a s_d -value of 2 m on the inner surface, the insulation system can be used up to a thickness of 6 cm, with the exception of very cold locations with high driving rain loads e.g. Fichtelberg.
- It should be noted that for natural fibre-based insulation materials, the strict limit values of DIN 68800-2 [21] were used for evaluation.

Note: The results of the current research project In2EuroBuild show that many natural fibre insulation materials used as interior insulation can also tolerate significantly higher moisture conditions and are just as resistant or even more resistant than solid wood. A hemp fibre insulation board has not yet been tested. Nevertheless, the following applies: If this resistance has been tested and confirmed for the respective material used, the application limits can be extended accordingly.

The results tables can be found in the EneffID project report in chapter 3.8.3 (p. 215) as well as in the appendices referenced there.

Cork-clay insulation board

The following areas of application and limits resulted for the exemplary cork-loam insulation board examined:

- Even with high moisture loads in the room, none of the variants considered fail, but there are sometimes additional requirements for the substrate.
- An additional vapour-barrier is usually not necessary, as the insulation system itself is sufficiently vapour-barrier.
- It should be noted that for natural fibre-based insulation materials, the strict limit values of DIN 68800-2 [21] were used for evaluation.
- Since cork is presumably much less sensitive to moisture than wood and wood-based materials, it might make sense to check which moisture limit values are suitable for the material. If necessary, it would also be conceivable to use the material in a much more humid environment.

Note: The results of the current research project In2EuroBuild show that many natural fibre insulation materials used as interior insulation can also tolerate significantly higher moisture conditions and are just as resistant or even more resistant than solid wood. If this resistance has been tested and confirmed for the respective material used, the application limits can be extended accordingly. In the final report at the time, it was already pointed out that cork probably has a particularly high resistance to moisture due to its other areas of application.

The results tables can be found in the EneffID project report in chapter 3.8.4 (p. 218) as well as in the appendices referenced there.

Aerogel high-performance insulating plaster

The following areas of application and limits resulted for the aerogel high-performance insulating plaster examined as an example:

- Both the condition with an initial moisture content due to the installation and the steady-state condition of the system were evaluated.
- No variant resulted in additional requirements for the second calculation year (with built-in moisture) that do not also exist in the steady-state condition. A special consideration of the moisture introduced by the insulation plaster is therefore not necessary.
- Even with high moisture loads in the interior, no variant in the standard cross-section was classified as unsuitable, but in some cases there are additional requirements for the substrate.

The results tables can be found in the EneffID project report in chapter 3.8.5 (p. 221) as well as in the appendices referenced there.

High-performance insulating plaster

The following areas of application and limits resulted for the high-performance insulating plaster examined as an example:

- All the variants considered were damage-free and functional even with high inner moisture loads according to DIN EN 15026 [23]. However, in about half of the cases there were additional requirements for the existing wall.
- The insulating effect is rather moderate, especially with a low layer thickness.
- Since a considerable amount of moisture is also introduced into the construction by the plaster system self, the second calculation year, which in most cases has not yet settled, was also considered in summary.
- No variant resulted in additional requirements for the second calculation year (with built in moisture) that do not also exist in the steady-state condition. Special consideration of the moisture introduced by the insulation plaster is therefore not necessary.

The results tables can be found in the EneffID project report in chapter 3.8.6 (p. 223) as well as in the appendices referenced there.

Mineral insulation board

The following areas of application and limits resulted for the mineral insulation board examined as an example:

- All the variants considered were damage-free and functional even under high internal moisture loads according to DIN EN 15026 [23]. However, for many of the variants under consideration, there were additional requirements for the substrate.
- The additional requirements resulted mainly from exceeding the limiting moisture content of 95% RH according to the WTA 6-5-14 [12] in the area of the boundary layer.
- In addition, the influence of the adhesive layer was considered for this insulation system; explicitly, a lightweight and a thin-bed mortar were considered.
- Due to the slightly lower re-drying potential of the existing wall, the system with thin-bed mortar tended to lead to slightly higher water contents than the variant with light mortar.
- The thin-bed mortar thus behaved slightly more critically and showed no advantages over the normal light mortar.

The results tables can be found in the EneffID project report in chapter 3.8.7 (p. 225) as well as in the appendices referenced there.

Organic aerogel insulation board

For the organic aerogel insulation board examined as an example, the following areas of application and limits resulted:

- All the variants considered were damage-free and functional even with high inner moisture loads according to DIN EN 15026 [23]. There were additional requirements for the substrate for approximately 40% of these variants.
- An additional s_d - value of 2 m on the inner surface had a positive effect on the evaluation in most variants.
- Despite the low insulation thicknesses of maximum 3 cm, good insulation effects were achieved.

The results tables can be found in the EneffID project report in chapter 3.8.8 (p. 228) as well as in the appendices referenced there.

Mineral aerogel insulation board

For the mineral aerogel insulation board examined as an example, the following areas of application and limits resulted:

- All the variants considered were damage-free and functional even under high internal moisture loads according to DIN EN 15026 [23]. For approx. 25% of these variants, there were additional requirements for the existing structure.
- The additional requirements arose mainly for the weathering wall layer of the double-skin masonry, where the frost resistance of the clinker must be ensured after the measure.
- An additional s_d -value of 2 m on the inner surface did not improve the evaluation of the variants.

The results tables can be found in the EneffID project report in chapter 3.8.9 (p. 231) as well as in the appendices referenced there.

Expanded polystyrene (EPS)

The following areas of application and limits resulted for the EPS insulation examined as an example:

- Different EPS panels were considered, a composite panel of grey EPS and a laminated gypsum board, and a white EPS panel with a gypsum-based internal plasterboard.
- When using the composite panel, all the variants considered are functional with high moisture loads in the interior according to DIN EN 15026 [23]. For approx. 25% of the variants, there are additional requirements for the moisture and frost resistance of the substrate.
- An additional s_d value of 2 m on the inner surface did not improve the evaluation of the variants.
- Despite the thermal advantages of grey EPS, no differentiation between the two systems is required for the same insulation thickness.
- For worst-case considerations, it can be assumed that if the composite panel is proven to be functional, the plastered variants with white EPS would also be functional.

The results tables can be found in the EneffID project report in chapter 3.8.10 (p. 233) as well as in the appendices referenced there.

A III Preparation of a simplified verification according to WTA guideline 6-4

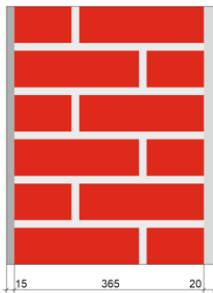

Print Summary of Results

Thermal transmission coefficient of the construction (moisture dependent) $U = 1,256 \text{ W}/(\text{m}^2\text{K})$
 Thermal transmission coefficient of the construction (dry) $U = 1,256 \text{ W}/(\text{m}^2\text{K})$
 Thermal transfer resistance of the construction (dry) $R = 0,506 \text{ m}^2\text{K}/\text{W} > 0,4 \text{ m}^2\text{K}/\text{W}$
 No condensation.
 DIN 4108-2 2013 Tab. 3 row 1, thermal resistance $R \geq 1,20 \text{ m}^2\text{K}/\text{W}$
 DIN 4108-3 (with capillary suction) $M_c \leq 1.0 \text{ kg}/\text{m}^2$
 Drying time in summer $t_w < 90\text{d}$

Requirement not fulfilled
 Requirement fulfilled
 Requirement fulfilled

Material Properties

Material	d [mm]	ρ [kg/m ³]	λ [W/mK]	μ [---]	W_{80} [m ³ /m ³]	W_{sat} [m ³ /m ³]	A_w [kg/m ² h ^{1/2}]
1 Lime plater (historical)	15,0	1800	0,8200	12,0	0,0111	0,3017	7,6200
2 Old building brick Dresden ZB	365,0	1769	0,7886	8,6	0,0091	0,3491	9,0000
3 Lime cement plaster	20,0	1900	0,8000	15,0	0,0530	0,2200	1,9980

Substrate is absorbent

d - layer thickness, λ - design value of thermal conductivity, μ - vapour diffusion resistance factor, W_{80}/W_{sat} - moisture content for 80% RH. resp. saturation, A_w - water uptake coefficient, layers from left to right

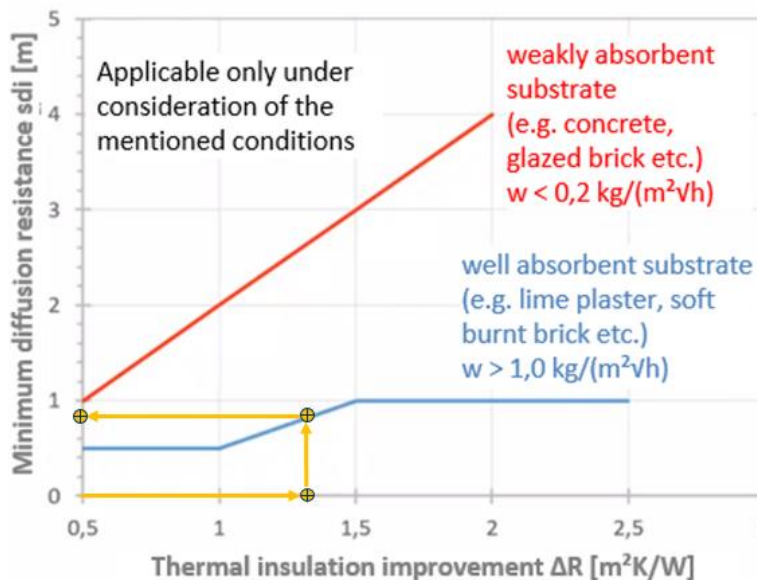

Notizen:

- $R_{exist. wall} > 0,4 \text{ m}^2\text{K}/\text{W}$
- Substrate is absorbant
- $\Delta R_i = 1,36 \text{ m}^2\text{K}/\text{W}$
- $s_d = 0,93 \text{ m}$
- $s_{d,min} = 0,86 \text{ m}$

$s_d > s_{d,min}$



Perlitefilled brick WDF 80 with backfill mortar

(1) Thermal insulation improvement ΔR_i

$$\Delta R_i = s/\lambda = 0,02 \text{ m} / 0,175 \text{ W}/\text{mK} + 0,08 \text{ m} / 0,065 \text{ W}/\text{mK} + 0,01 \text{ m} / 0,51 \text{ W}/\text{mK} = 1,36 \text{ m}^2\text{K}/\text{W}$$

(2) Determination of the s_d -value

$$s_d = \mu * s = 0,02 \text{ m} * 20 + 0,08 \text{ m} * 5 + 0,01 \text{ m} * 13 = 0,93 \text{ m}$$

Characteristic values of interior insulation

Material	d [m]	λ [W/mK]	μ [-]
1 Backfill mortar	0.02	0.175	20
2 WDF 80	0.08	0.065	5
3 Internal plaster	0.01	0.510	13

A IV Boundary conditions for the simplified verification for the classification of vapour permeable, capillary-active insulation materials

For the classification of the insulation material, it is necessary to determine the hygrothermal material characteristics including a determination of the capillary return conductivity (so-called capitest [33] or condensation test [34]). Then the behaviour of the material is simulated under standardised boundary conditions, which were derived from real and normative requirements. They are representative for a critical winter scenario (stationary reference simulation) for the above-mentioned areas of application. In this scenario, the previously mentioned limit values of relative humidity must not be exceeded. The reference simulation was validated as critically representative by a comprehensive comparison with simulations under real climate conditions. The insulation material or insulation system is then classified on this basis - depending on how the manufacturer markets its product. The structure of the construction and the boundary conditions of the reference simulation are shown in Fig. 29 and Tab. 7 respectively.

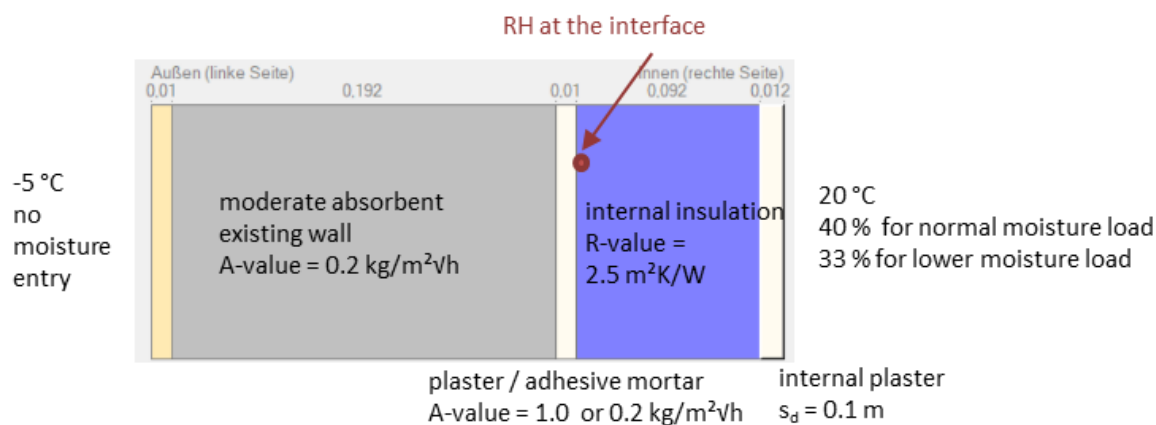

Fig. 29 Structure and boundary condition of the reference simulation

The construction is based on a moderately absorbent masonry- or concrete wall with an A-value of 0.2 kg/m²/h. The R-value of the interior insulation is assumed to be 2.5 m²K/W based on the application limits of WTA data sheet 6-4 (WTA-guideline 6-4-16 [4]). The existing masonry is dimensioned to meet the old minimum thermal insulation ($R \geq 0.4$ m²K/W) according to DIN 4108-2 [17]; with a thermal conductivity of 0.48 W/mK, this results in a thickness of 19.2 cm for the masonry. The other boundary conditions of the simulation are summarised in Tab. 7 compiled.

The temperatures of the outdoor and indoor climate are assumed to be constant at -5 °C and 20 °C respectively, as in the "standard winter" from DIN 4108. Following the indoor climate models for hygrothermal simulation, the relative humidity in the room is assumed to be 40 % RH for a "normal humidity load" and 33 % RH for a "low humidity load". No rain absorption is calculated on the external surface, which is a prerequisite for using the simplified verification. If this cannot be guaranteed, an individual simulation with the site-specific outdoor climate and rain data is necessary.

For the evaluation of the reference simulation, the relative humidity at the boundary layer between the existing masonry and the interior insulation system at the end of the three-month standard winter is considered and the insulation material or system is classified in category A or B for each of the three application areas.

Tab. 7 Boundary conditions for the steady-state reference simulation

Exterior surface	
Outdoor climate	-5 °C, relative humidity: any, as no humidity exchange is calculated
Inclination	90 °
External transition coefficient	17 W/m ² K
Additional s_d -value outside	10000 m (No humidity exchange with outside air)
Rainwater absorption coefficient	No rain recording
Inner surface	
Indoor climate	Temperature: 20 °C relative humidity: 40 % (moisture load normal) 33 % (moisture load low)
Transition coefficient inside	8 W/m ² K
Other	
Initial moisture:	Equilibrium moisture at 70 % RH.
Calculation period	3 months

A V Evaluation of the classification of vapour permeable, capillary-active insulation materials

According to the evaluation scheme described above, more than 20 different vapour permeable, capillary-active interior insulation materials were evaluated. Most of them achieved either category A (generally functional) or category B (functional with moisture resistance), depending on the area of application. However, some systems achieved moisture contents above 99 % RH in application area II (moderately absorbent substrate, low moisture load) and III (well absorbent substrate, low moisture load), so that no direct classification into the two categories was possible for these systems. However, further investigations have shown that the moisture level on the cold side of the insulation can be positively influenced in a simple way by a minimally increased vapour-barrier effect of the interior coating. If the s_d value of the inner coating is moderately increased from 0.1 m to 0.2 m for application area I or to 0.5 m for application areas II and III, the condition "open to diffusion" is still fulfilled, but all investigated insulation systems examined could be grouped in category A with this small change.

Tab. 8 Categorisation of the interior insulation materials examined

Material	Application area					
	I		II		III	
	well absorbent substrate ($A \geq 1.0 \text{ kg/m}^2\text{vh}$) and low moisture load (WTA 6-2)		moderate absorbent substrate ($A \geq 0.2 \text{ kg/m}^2\text{vh}$) and low moisture load (WTA 6-2)		well absorbent substrate ($A \geq 1.0 \text{ kg/m}^2\text{vh}$) and normal moisture load (WTA 6-2)	
sdi = 0.1 m	sdi = 0.2 m	sdi = 0.1 m	sdi = 0.5 m	sdi = 0.1 m	sdi = 0.5 m	
aerogel insulation board-1	●	●	●	●	●	●
aerogel insulation board-2	●	●	●	●	●	●
aerogel insulation board-3	●	●	●	●	●	●
calcium silicate-1	●	●	●	●	●	●
calcium silicate-2	●	●	●	●	●	●
cellulose fiber-1	●	●	●	●	●	●
cellulose fiber-2	●	●	●	●	●	●
hemp fibre board	●	●	●	●	●	●
insulation plaster-1	●	●	●	●	●	●
insulation plaster-2	●	●	●	●	●	●
insulation plaster-3	●	●	●	●	●	●
mineral faser, hydrophilic-1	●	●	●	●	●	●
mineral faser, hydrophilic-2	●	●	●	●	●	●
mineral foam board-1	●	●	●	●	●	●
mineral foam board-2	●	●	●	●	●	●
perlite insulation-1	●	●	●	●	●	●
perlite insulation-2	●	●	●	●	●	●
wood fiber-1	●	●	●	●	●	●
wood fiber-2	●	●	●	●	●	●
wood fiber-3	●	●	●	●	●	●
wood fiber-4	●	●	●	●	●	●
wood fiber-5	●	●	●	●	●	●
wood fiber-6	●	●	●	●	●	●

- Functional (category A)
- Functional if insulation system and substrate moisture, frost and rot resistant (cat. B)
- Condensation possible. Individual verification required.

In the context of the investigations, it was also noticed that within certain material types, such as aerogel-containing materials, mineral insulation boards and wood fibre insulation, significant product-specific differences can be observed. Here, it is therefore explicitly not possible to draw conclusions from one similar material to another, but the material behaviour must be determined and evaluated individually for each material.

A VI Characteristic values, boundary conditions and evaluation criteria for hygrothermal simulations

In the following, characteristic values and boundary conditions according to WTA-guideline 6-2-14 [18] for the creation of the hygrothermal simulation are described, and information on evaluation and assessment criteria is also provided.

Material characteristics

Thermal and hygric material parameters are required for the simulation, the scope of which must comply with the requirements of WTA bulletin 6-2; in the case of interior insulation materials, the material measurements are supplemented by a so-called Kapi or condensation test.

The databases of the available simulation programs contain a large number of already characterised materials. If material parameters from the as-built analysis are available, a suitable material can be selected from the software's material database and adapted. In the case of uncertain parameters, it is recommended to carry out a variant analysis to determine how great the influence of this parameter is on the moisture behaviour of this construction. In case of doubt or if the influence on the construction is too great, a detailed hygrothermal laboratory investigation of the material or at least the parameter should be carried out.

Many frequently used interior insulation systems and their components are already included in the material databases of the software or are to be provided by the manufacturers.

Climate data

Suitable climate data sets (hourly values) for the outdoor climate are usually available for transient simulations.

To model the indoor climate, the WTA bulletin offers a derivation of the transient indoor air conditions from the outdoor air temperatures and according to the planned use with the help of the following diagrams. For the standard case, "normal damp load" is used or "normal damp load + 5%" for general dimensioning. The "high humidity load" should only be selected if exceptionally high humidity loads are to be expected.

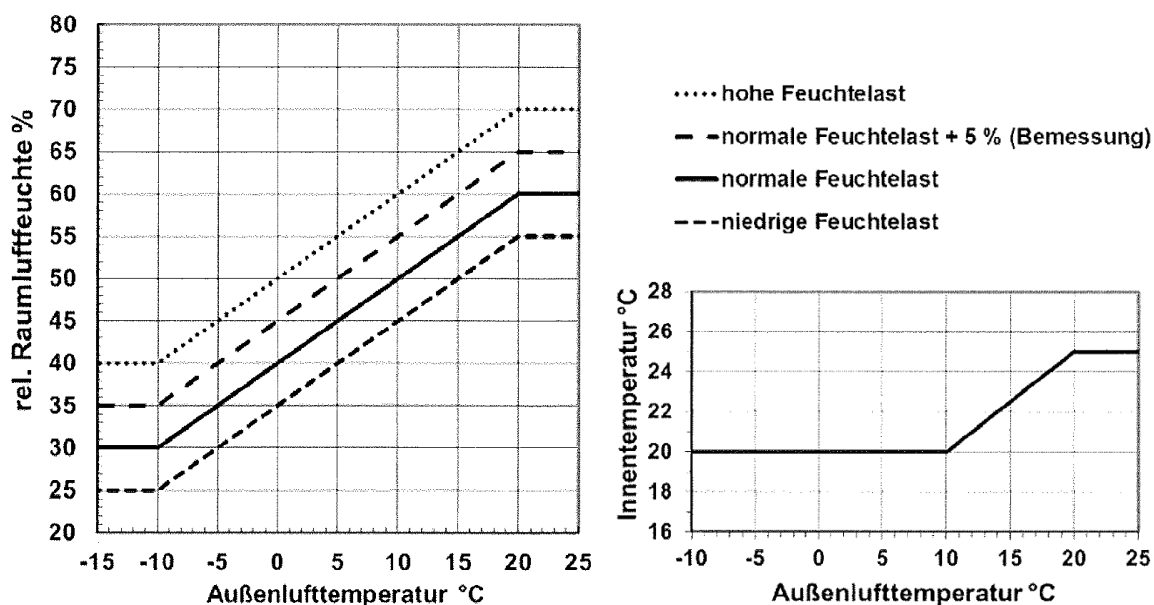

Fig. 30 Derivation of the indoor air temperature and humidity as a function of the outdoor air temperature according to WTA-guideline 6-2-14 [18]

Alternatively, deviating room climate conditions can be used, e.g:

- Existing measured values for the specific or a similar building
- Results from previously conducted building or room simulations
- Use of predefined usage requirements and limitations

The resulting indoor climate is strongly determined by the user's behaviour or by building services equipment, but also by the storage properties of the adjacent building components and furnishings.

Initial conditions

The moisture in a construction must be recorded as accurately as possible in order to be taken into account as the initial state of the simulations. The material moisture can be entered, for example, on the basis of moisture measurements for the concrete layers; for new material layers to be installed, the installation moisture is used.

As a rule, the behaviour of the internally insulated construction is of interest, for which the initial temperature and humidity often only play a subordinate role. However, especially in the case of materials at risk of frost or constructions with wood or wood-based materials or constructions that are sealed tightly, the influence of the installation moisture can play an important role and must therefore be taken into account.

Duration of the simulation, start time

The simulation is carried out until a steady state is reached, but at least over a period of 3 years. In principle, the calculation can be started at any time. If no specific information is available, it is recommended to start the calculation from the beginning of October. In this way, the critical case of the combination of installation moisture and diffusive moisture entry from the interior into the wall in winter is mapped. It also covers three complete winter periods.

Expenditure

For the calculated constructions, many different outputs, such as temperature, rel. humidity, degree of moisture penetration and water content at different positions can be visualised over time. It makes sense to check room-side surfaces as well as critical positions such as the cold side of the insulation with adhesive mortar (potential condensation level), existing interior surface of the existing structure (masonry and plaster), moisture-sensitive materials (e.g. wood) as well as the existing structure itself (influence from driving rain and frost, check for increase in saturation content as a result of the insulation measure).

Evaluation criteria

The WTA-guideline 6-5 [12] specifies transient verification for interior insulation systems. Proof is provided if the following criteria are met:

- **WTA criterion steady state:** A steady state is achieved. It must be demonstrated that there is no continuous moisture increase, i.e. after a transient phase, the moisture input and drying of the construction must be in balance. The steady state is reached when the annual total water content and the water content in individual material layers change by less than 1% compared to the previous year. For many constructions, three simulated years are sufficient for this.
- **WTA criterion durability:** In order to ensure the durability of the construction, long-term moisture damage must be excluded. For this purpose, the maximum occurring moisture conditions of the individual component layers and the surface are assessed.

If there is no deviating knowledge about the construction to be examined, the following requirements apply:

- **WTA criterion frost:** If the materials are presumably not frost-resistant, a degree of saturation of 30 % should not be exceeded (degree of saturation: ratio of the water content present to

the porosity). A higher degree of saturation is permissible as long as the relative humidity within the material layer remains below 95 %.

- **WTA criterion gypsum:** For gypsum-containing substrates, a relative humidity of 95 % should not be exceeded.
- **WTA criterion wood:** In wooden building components, the relative pore air humidity must not exceed 95 % at 0°C and 86 % at 30 °C on a daily average; intermediate values can be interpolated linearly. In the long term, 85 % relative humidity should not be exceeded over the course of the year.

So far, the criterion only applies to solid wood, not to wood-based materials. Within the framework of the project, however, it could be shown that e.g. certain wood fibre insulation materials are less sensitive to rot than the pine sapwood. With proven higher resistance, the criteria according to WTA can also be used for such wood fibre insulation materials.

- **WTA criterion mould:** The interior building component surfaces must remain mould-free, with reference to WTA guideline 6-3 [35]. This applies in particular to areas where the surface temperature factor f_{Rsi} is less than 0.7.

A VII Application example for a one-dimensional hygrothermal design

Konstruktionsskizze



Materialeigenschaften

	Material	d [mm]	ρ [kg/m ³]	λ [W/mK]	μ [---]	w_{80} [m ³ /m ³]	w_{sat} [m ³ /m ³]	A_w [kg/m ² h ^{1/2}]
1	Calsitherm KP-Kalkglätte	3,0	1250	0,2810	12,1	0,0134	0,5283	8,0243
2	Calsitherm Klimaplatte WF	50,0	187	0,0620	3,6	0,0068	0,9295	45,9372
3	Calsitherm KP-Kleber	5,0	1410	0,6000	22,9	0,1066	0,4680	0,2279
4	Kalkzementputz	15,0	1800	0,8000	12,0	0,0111	0,3017	7,6200
5	Hintermauerziegel	380,0	1769	0,8200	8,6	0,0091	0,3491	9,0000
6	Kalkzementmörtel	10,0	1570	0,8000	11,0	0,0252	0,4080	10,5600
7	Außenziegel 1	110,0	1999	0,8200	52,0	0,0031	0,2456	2,6100
8	Brennhaut Außenziegel 1	10,0	1999	0,8200	52,0	0,0031	0,2456	0,2000

d - Schichtdicke, λ - Rechenwert der Wärmeleitfähigkeit, μ - Dampfdiffusionswiderstandsfaktor, w_{80}/w_{sat} - Feuchtegehalt bei 80% relativer Luftfeuchte bzw. Sättigung, A_w - Wasseraufnahmekoeffizient, Schichten von links nach rechts

Fig. 31 Structural design and steady-state calculation of an internally insulated exterior wall

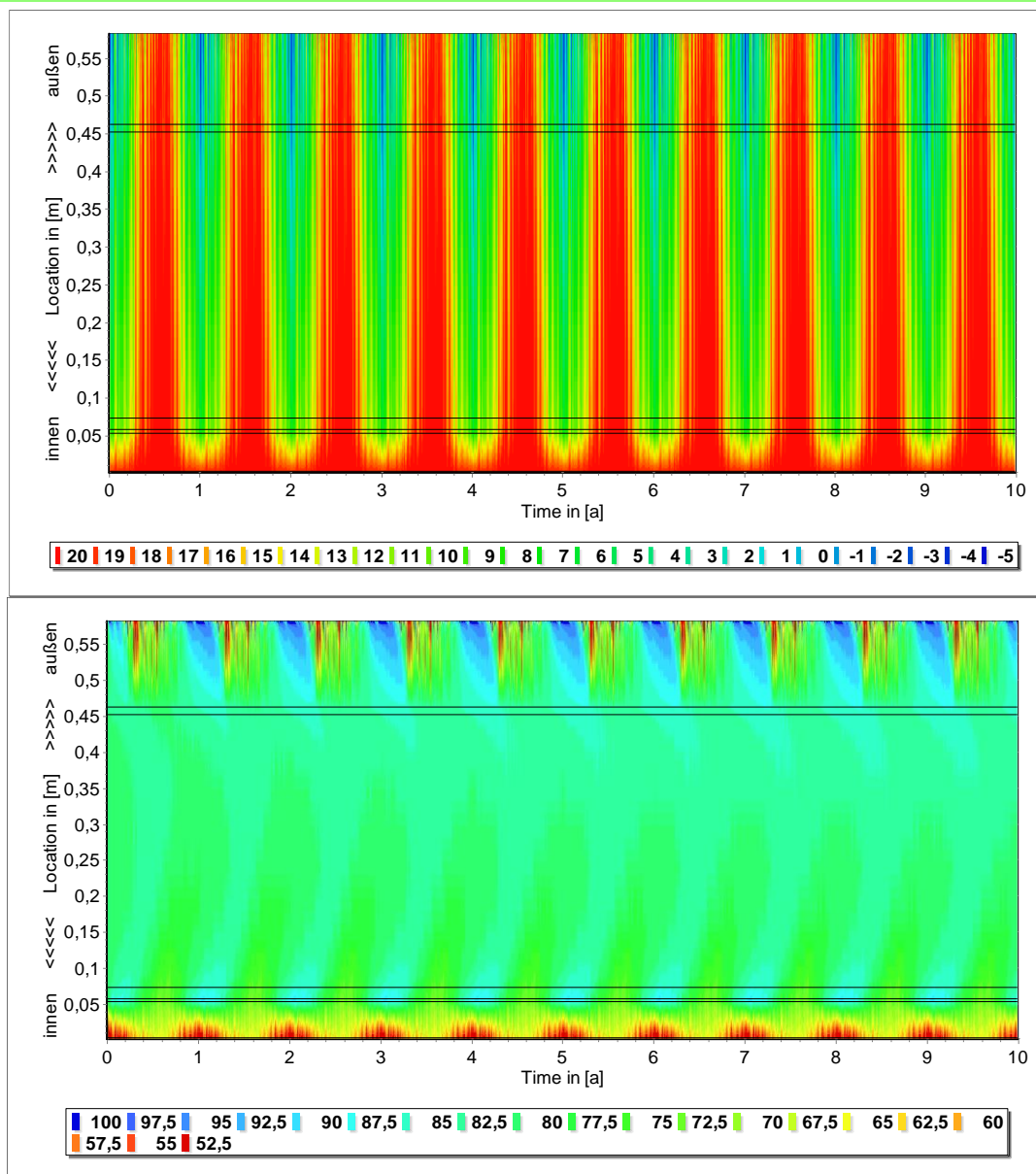

Fig. 32 Temperature and humidity field of an internally insulated construction, existing construction with compensation humidity, simulation period: 10 years, calculation with Delphin 6.0

In Fig. 32 the course of temperature and humidity over a period of 10 years is shown for the internally insulated wall construction. Time is plotted on the x-axis, temperature and humidity on the y-axis. The horizontal lines symbolise material layer boundaries. Along the upper boundary is the outer surface. In the temperature field, it can be seen that during the warm season, the entire construction is almost continuously above 20°C. The temperature in the upper part of the field is also above 20°C. Minus temperatures penetrate at most into the middle of the existing construction. From the lower humidity field in Fig. 32 shows that higher humidity loads only occur in the outer area.

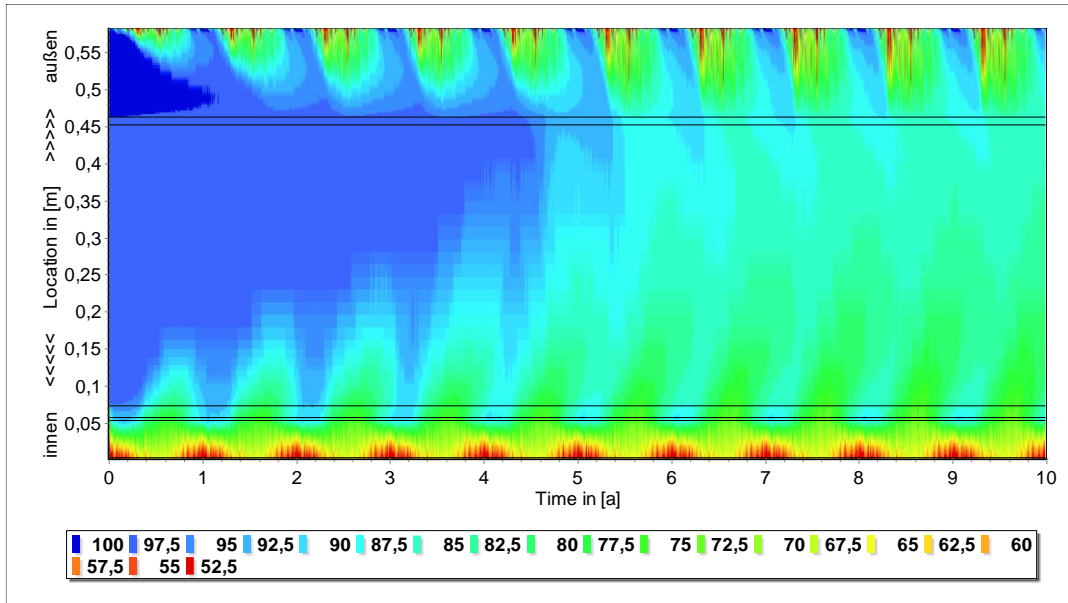

Fig. 33 Air humidity field of an internally insulated construction, existing construction with initial humidity, with representation of the drying behaviour, simulation period: 10 years , calculation with Delphin 6.0

In comparison, the existing structure in Fig. 33 was assigned a higher initial moisture content. As can be seen, the construction needs approx. 8 years until the steady state or the state without increased moisture load is reached.

The representations in Fig. 32 and Fig. 33 clearly illustrate the progression over time and give an impression of the hygrothermal processes in the one-dimensional, insulated wall construction. It can be seen how the construction with the selected insulation system can handle the additional moisture content.

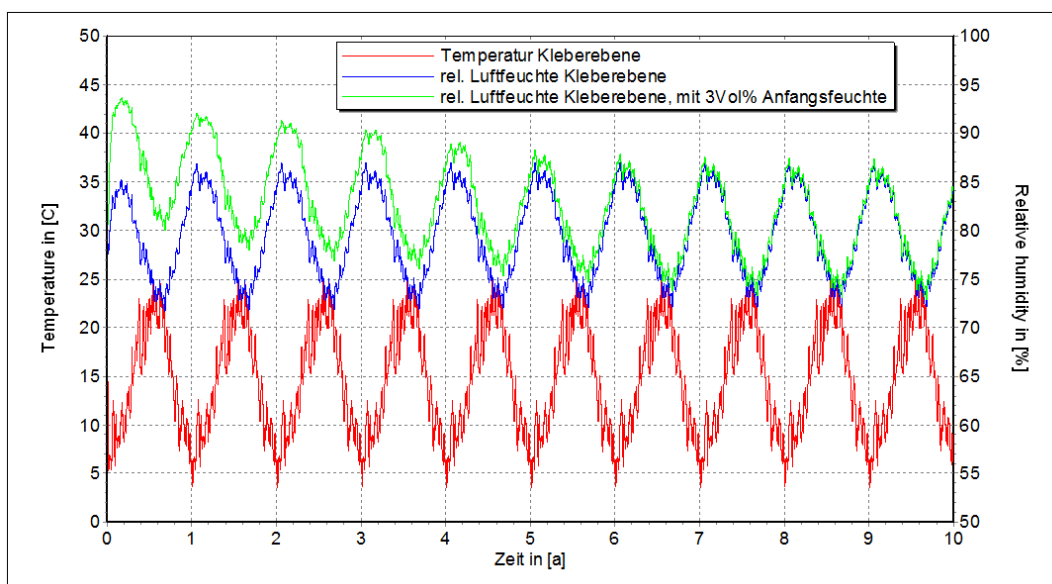

Fig. 34 Course of temperature and relative humidity in the adhesive layer of the interior insulation system, comparison of a construction with and without initial moisture content over 10 years

By evaluating the progression diagrams as shown in Fig. 34 statements can be made as to whether inadmissibly high moisture contents occur in the potential condensation level (here: level between the existing construction and the insulation system) and how great the influence is in this area due to, for example, an increased initial moisture content of the construction.

In the diagram, the temperature is plotted on the left axis and the humidity on the right axis. According to this, the simulation with increased initial humidity roughly corresponds to the simulation without initial humidity from about the sixth year onwards. Even with increased initial humidity, a relative humidity of 95% is not exceeded in the adhesive layer of the insulation system.

In this case, there is no risk of frost behind the interior insulation at minimum temperatures of +5°C.

A VIII Application examples for the hygrothermal design of connection details

Details of some standard component connections are presented below as examples.

Since the question of driving rain protection of the façade should already have been clarified at the time of the detailed design, an intact, sufficiently water-repellent façade is assumed for the following simulations.

Detail 1: Solid interior wall connection

Using the example of a solid interior wall integrating into the exterior wall at temperature fields in the Fig. 35 is used to illustrate the general effect of internal insulation on adjacent building components. To simplify matters, the boundary conditions according to DIN 4108-2 [17] were used for simplification: Interior temperature 20°C and exterior temperature: -5°C.

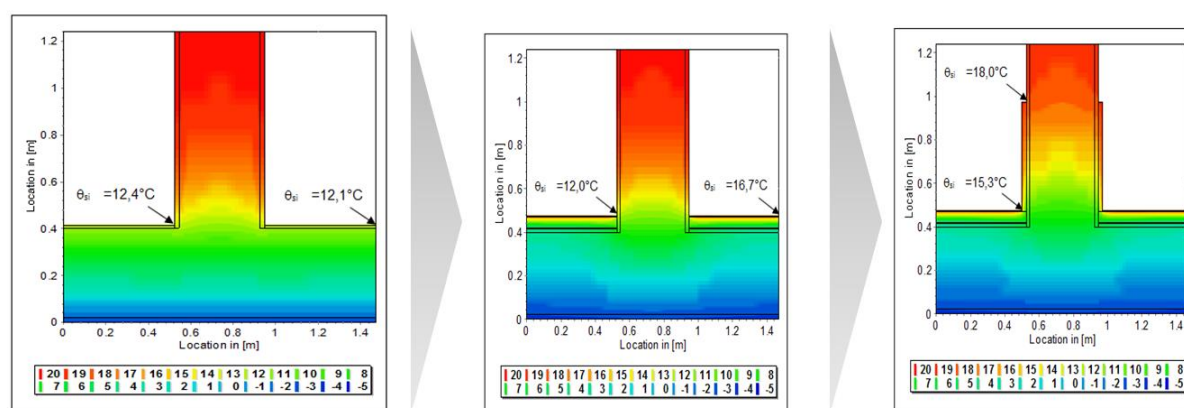

Fig. 35 Integrating interior wall into an exterior wall, left: without interior insulation, centre: with interior insulation, without flank insulation, right: with interior and flank insulation.

It can be seen that on the uninsulated exterior wall (Fig. 35 left) a low surface temperature occurs below the minimum thermal protection. In the area of the corner to the connecting interior wall, the temperature is slightly higher due to the heat input from the interior wall. With the application of interior insulation to the exterior wall (Fig. 35 centre), the surface temperature of the new inner surface of the outer wall increases, but the temperature level in the connection area to the inner wall decreases, as the existing outer wall now becomes colder. With the installation of flank insulation in the connection area (Fig. 35 right) significantly improves the thermal situation. This effect of penetration and decoupling must always be taken into account when considering the connection details. The greater the thickness of the existing exterior wall and the lower its U-value, the lower the probability that flank insulation will be necessary to comply with the minimum thermal insulation.

Detail 2: Partition wall connection - drywall new

In many renovation measures, new partition walls are erected, mostly in dry construction. These are usually fixed directly to the existing wall (at least if there are increased requirements) according to the manufacturer's specifications and for reasons of statics, fire protection and sound insulation. However, this also means that if internal insulation is planned, the C-profiles of the fastening

and the mineral fibre insert are located in the potential condensation plane. The stronger the interior insulation system, the greater the potential for damage.

In order to meet the building physics requirements, but at the same time the manufacturer's specifications, this connection detail was investigated in detail hygrothermally at the IBK of the TU Dresden and a practicable detail was developed that can be used for many situations of this connection. Thus, in most cases, a detailed verification can now be omitted.

In Fig. 36 the usual standard connection and the optimised connection are shown, whereby here a rim stone or flat lintel is attached vertically to the wall in order to move the connection of the drywall out of the hygric critical area.

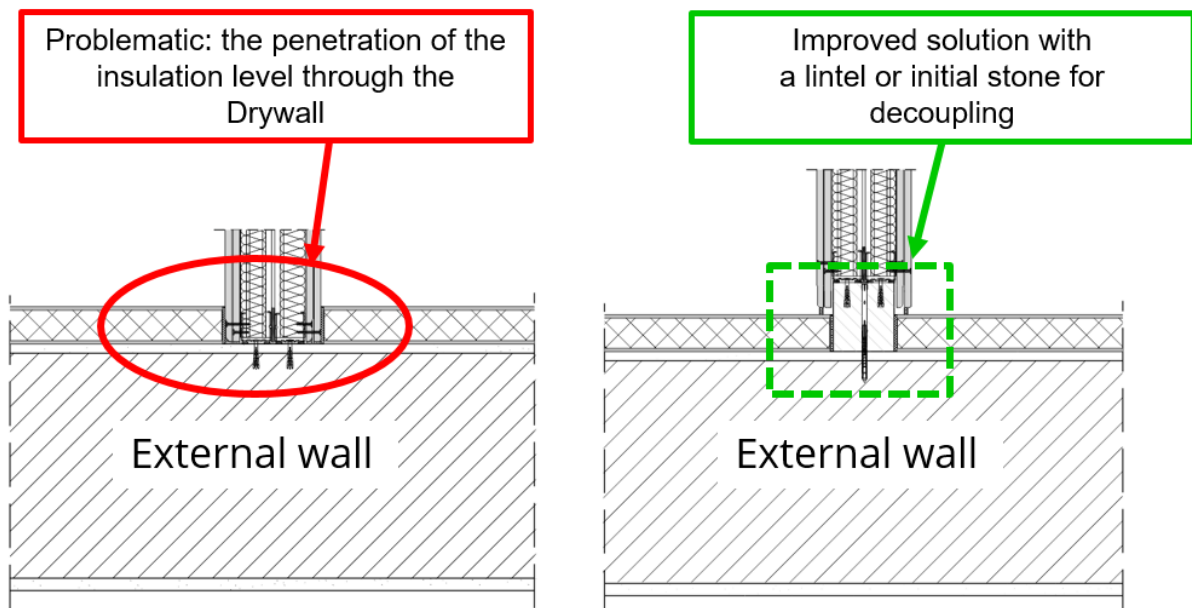

Fig. 36 Connection of a new drywall to be erected to an internally insulated exterior wall, left: Standard connection, right: with rim stone or lintel for hygric decoupling

A purely thermal analysis of this connection shows that the minimum thermal protection is complied with in both variants and that in a dynamic simulation the temperature in the connection corner is not critical, which is the case in the Fig. 37 and in the Fig. 38 can be seen.

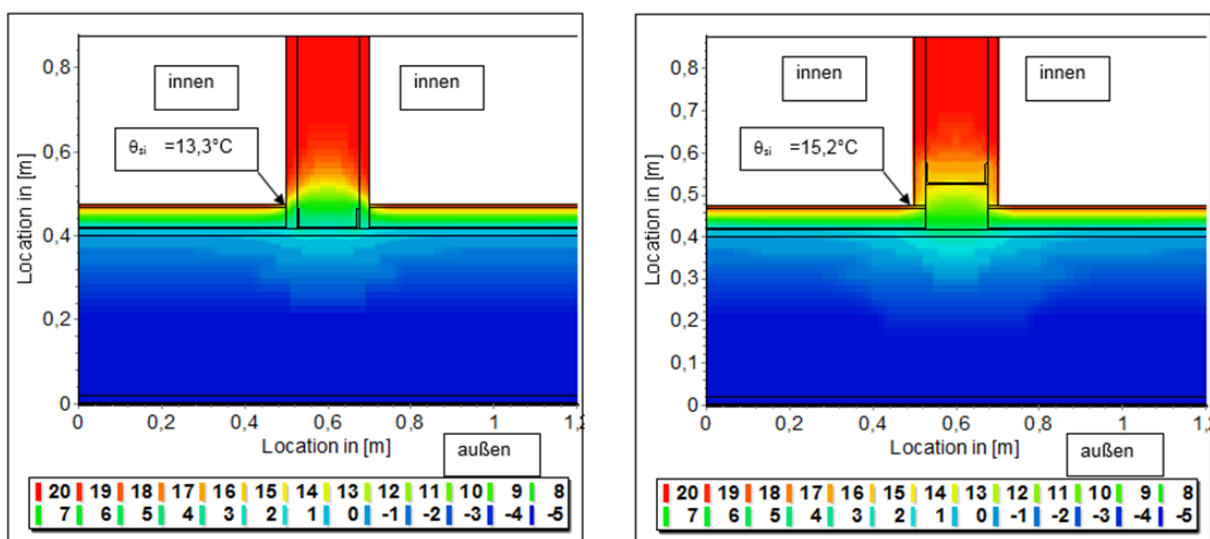

Fig. 37 Drywall connection to internally insulated exterior wall, temperature field on 10.01. of the 3rd year of calculation with real climate conditions, left: Standard connection, right: with rim stone or lintel for hygric decoupling

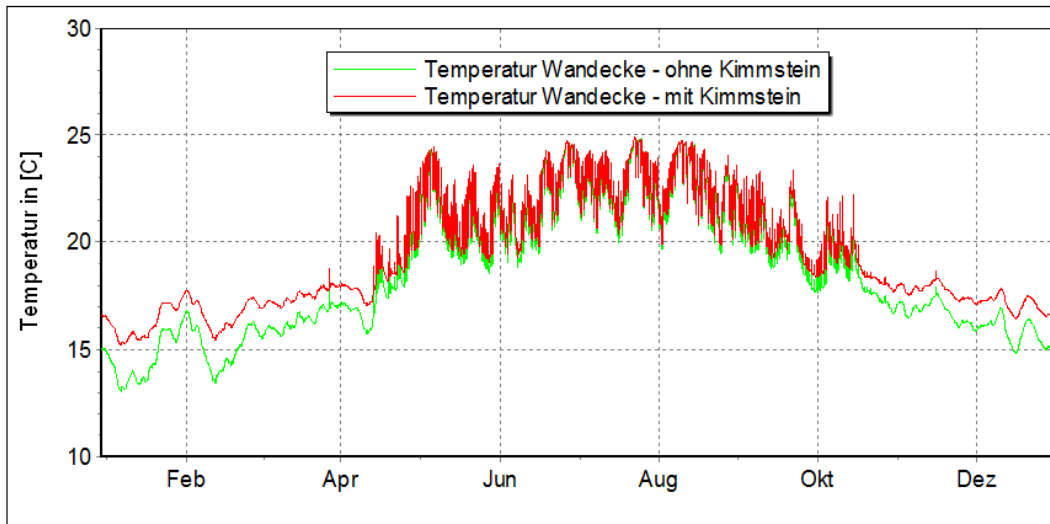

Fig. 38 Drywall connection to internally insulated exterior wall, course of the temperature in the wall corner in the 3rd year of calculation, with real climate conditions, left: Standard connection, right: with rim stone or lintel for hygric decoupling

Only when considering the hygric conditions does it become clear that the connection of the drywall with penetration of the thermal plane can become hygric critical. This is shown in the representation of the humidity field for both variants on an identical day in the Fig. 39.

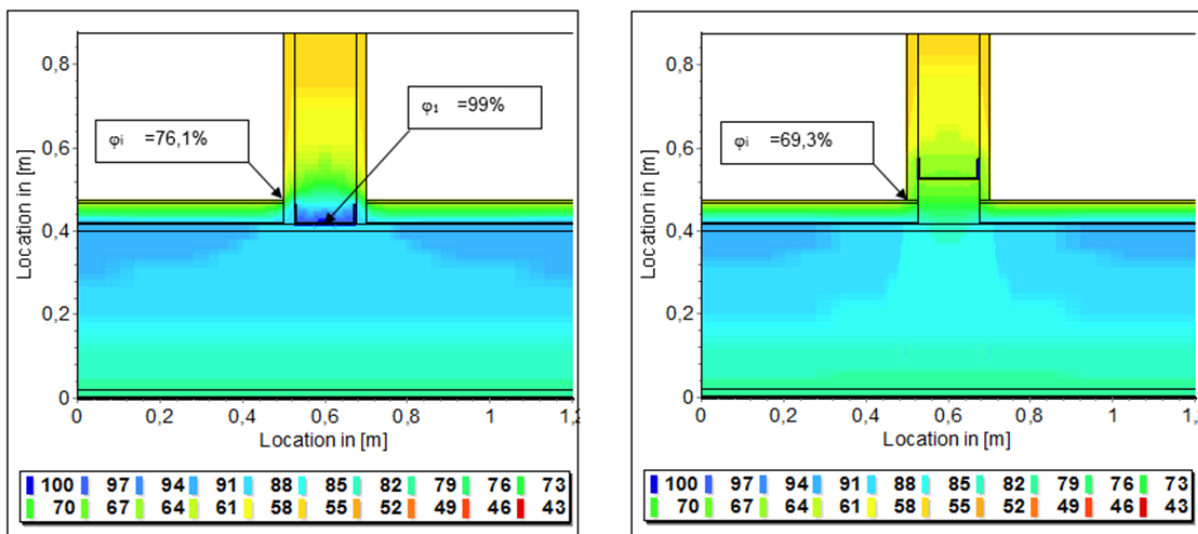

Fig. 39 Drywall connection to internally insulated exterior wall, air humidity field on 24.04. of the 3rd year of calculation with real climate conditions, left: Standard connection, right: with rim stone or lintel for hygric decoupling

This effect can be seen even more impressively in the course of the relative humidity in this connection area. Fig. 40 the course over 2 calculation years is shown below. It can be seen that the relative humidity is approx. 99% over a period of approx. 3 months. This means that there is a risk of condensation occurring, which can be associated with corrosion of the cut surfaces of the C-profiles or moisture penetration of the mineral fibre insulation in the connection area. In the example, the internal insulation thickness is 5 cm. This effect is even more pronounced with greater insulation thickness.

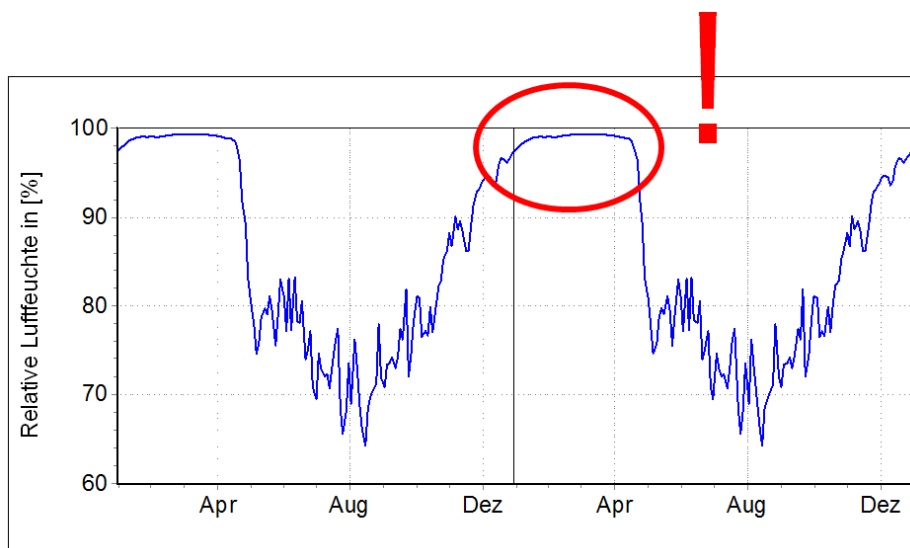

Fig. 40 Connection of drywall to internally insulated exterior wall, course of relative humidity in the critical connection area in the 2nd and 3rd year of calculation with real-climate conditions for standard connection

At Fig. 41 the course of the relative humidity in the corner of the wall is shown for both variants, whereby it can be seen that the optimised variant has significantly lower humidity in the winter half-year and is therefore less critical.

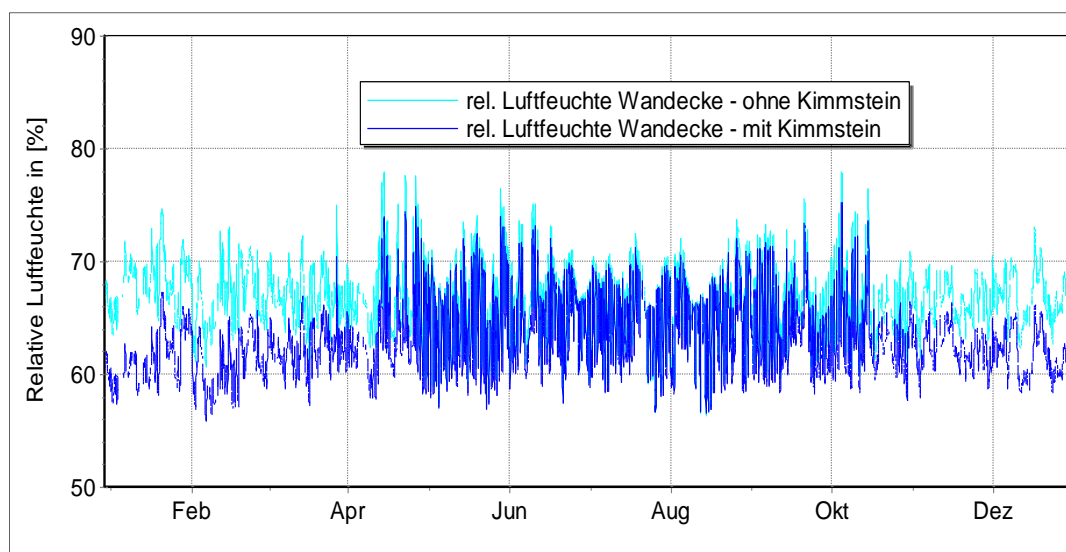

Fig. 41 Connection of drywall to internally insulated exterior wall, Course of relative humidity in the wall corner in the 3rd year of calculation, with real climate conditions,

Detail 3: Window reveal

The upgrading of the window connection is an important topic in almost every existing building in the context of energy renovation with interior insulation.

The example of a window reveal (Fig. 42) is used to explain the verification process. An important prerequisite for ensuring the minimum hygienic thermal protection is the creation of a continuous insulation level. This is usually easy to achieve with the installation of new windows, as the windows require a certain tolerance for adjustment during installation. This means that there is usually 2-3 cm of space between the masonry and the frame. After the windows have been installed, this gap is filled with an insulating material suitable for this application (e.g. PUR foam or a pre-compressed sealing tape). Thus, the connection of the reveal insulation can be continued at this level and the critical connection can be defused.

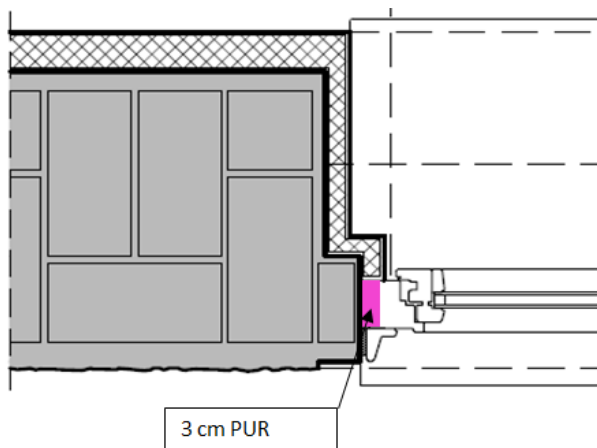

Fig. 42 Window reveal connection of an internally insulated wall, position of the window almost flush with the outside. Attention must be paid to a continuous insulation level.

When verifying the minimum hygienic thermal protection according to DIN 4108-2 [17], it can be seen that the selected solution complies with the minimum thermal protection and that the temperature in the corner required under steady-state boundary conditions according to DIN 4108-2 [17] ($> 12.6^{\circ}\text{C}$) is just met at 12.9°C , which can be seen in the Fig. 43 can be seen.

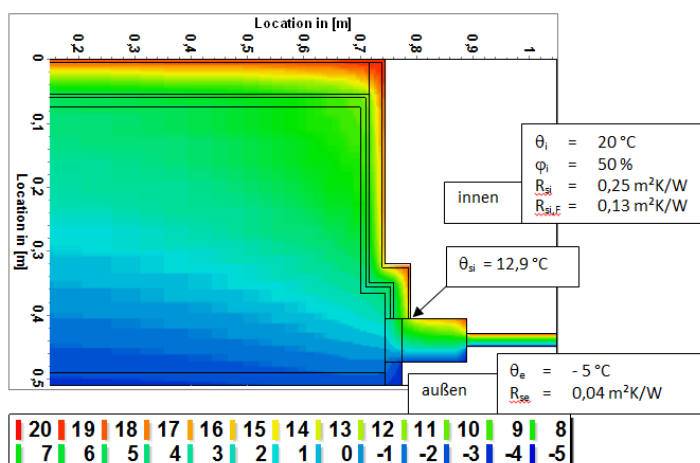

Fig. 43 Temperature field, surface temperature in $^{\circ}\text{C}$, window reveal on exterior wall $d = \text{AW } 38 \text{ cm}$, interior insulation 5 cm , reveal insulation 2.5 cm , boundary conditions according to DIN 4108-2 [17]

$$\theta_{si, \text{present}} = 12.9^{\circ}\text{C} > \theta_{si, \text{permissible}} = 12.6^{\circ}\text{C}$$

In a further step, the hygrothermal verification for this detailed connection is provided. In the Fig. 44 the temperature field and the humidity field for a critical day of the 3rd year of calculation are shown.

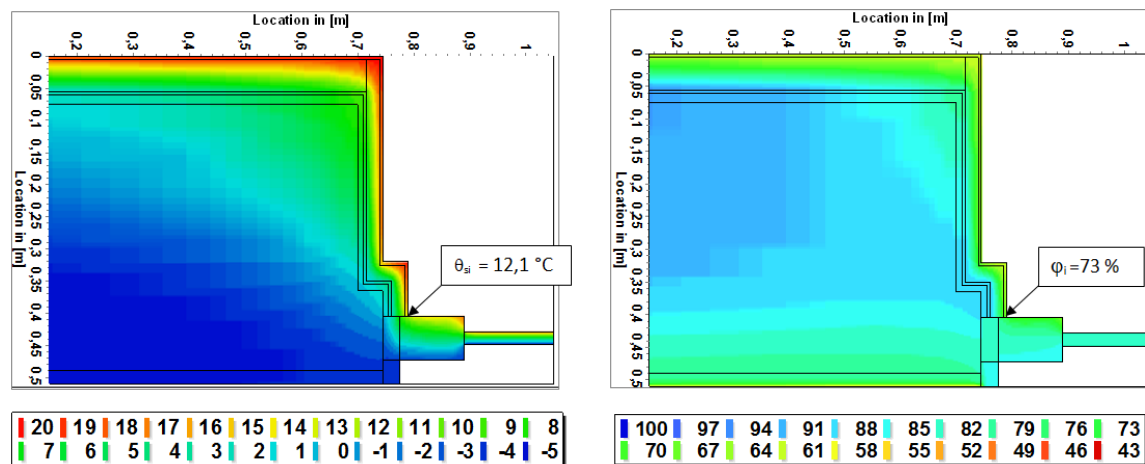

Fig. 44 Right: temperature field, surface temperature in °C and left: Air humidity field in % for the window reveal connection

In addition, the course of temperature and rel. humidity (Fig. 45 and the annual cycle of temperature and humidity, plotted with a limiting curve for the germination of moulds on easily digestible substrate (Fig. 46).

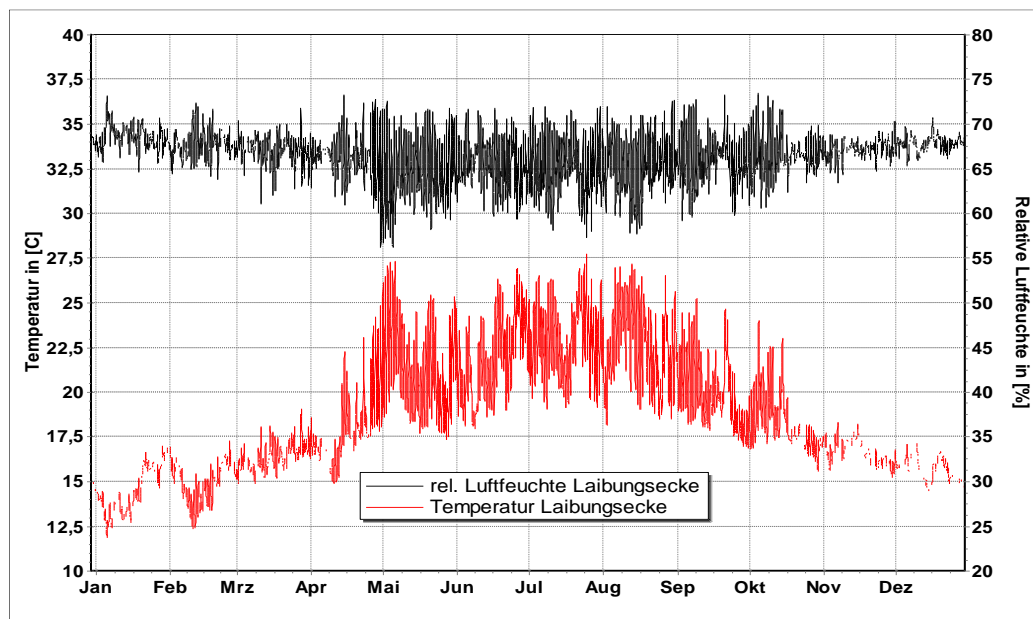

Fig. 45 Course of surface temperatures in °C and relative humidity in % in the window reveal, shown for the 3rd year of calculation starting on 1 January

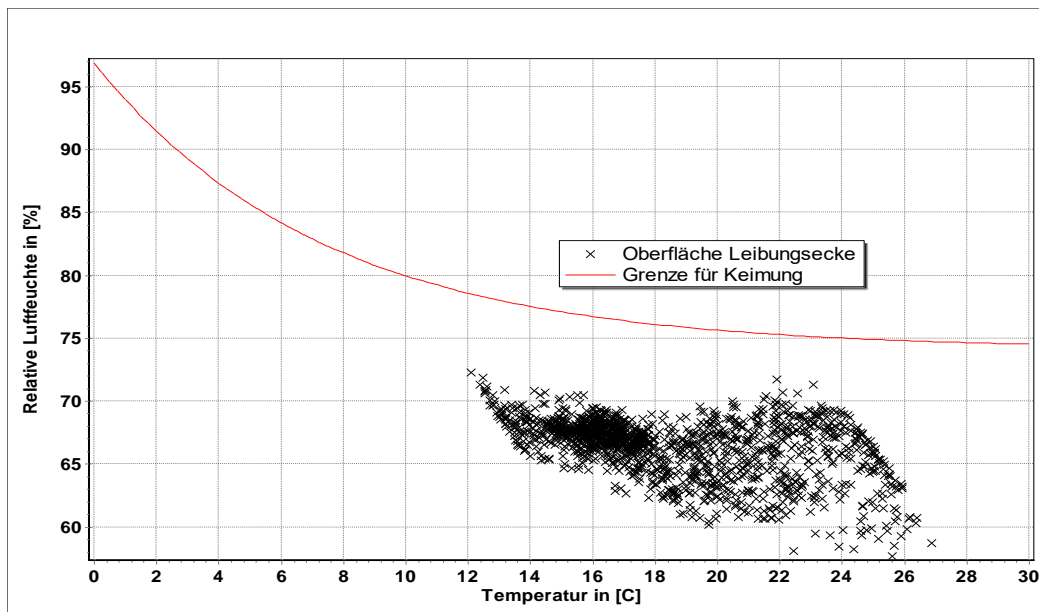

Fig. 46 Annual cycle of temperature and relative humidity in the soffit corner in the window soffit corner, isopleth for germination of mould fungi on readily usable substrate, shown the 3rd calculation year with start on 01 January

It can be seen from the figures that no critical values occur in the calculation under real-climate conditions. The surface temperatures in the corner area of the reveal connection are only temporarily below the mould limit temperature (according to DIN 4108-2 [17]) even on cold days, the corresponding rel. humidity rises in isolated cases up to approx. 73%. Thus, with the selected climatic conditions, moisture and mould damage near the surface is not to be expected for this connection.

A IX Typical connection details

In the following, some typical connection details principle representations for different installation situations are suggested.

0 Overview of interior insulation variants

Integrating inner wall

- 1.1 Integrating existing interior wall with straight or wedge-shaped flank insulation
- 1.2 Integrating existing interior wall, connection with heat conduction plate
- 1.3 Integrating new monolithic interior wall
- 1.4 Connecting new dry construction partition (within the utilisation unit)
- 1.5 Connecting new dry construction partition (as partitioning wall)

Storey ceiling

- 2.1 Integrating existing solid ceiling with flanking insulation
- 2.2 Integrating existing solid ceiling with heat conduction plate
- 2.3 Integrating new solid ceiling with front side insulation
- 2.4 Timber ceiling without opening the historical ceiling, midspan
- 2.5 Timber ceiling with opening the historical ceiling, midspan
- 2.6 Timber ceiling without opening the historical ceiling, cut through the beam
- 2.7 Timber ceiling with opening the historical ceiling, cut through the beam
- 2.8 Timber ceiling without opening the historical ceiling, trimmer beam
- 2.9 Timber ceiling with opening the historical ceiling, trimmer beam

Windows

- 3.1 Window reveal with rabbet
- 3.2 Window reveal without rabbet, window in level with façade surface
- 3.3 Window reveal without rabbet, window in the centre of the wall
- 3.4 Window breast, window in the centre of the wall

IN2EuroBuild



Annex to the Guideline for Interior Insulation - Construction details

Vapour-permeable, capillary-active system with insulation board

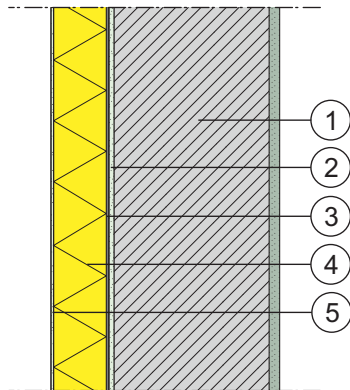

Vapour-permeable, capillary-active system with plastic materials (insulating plaster)

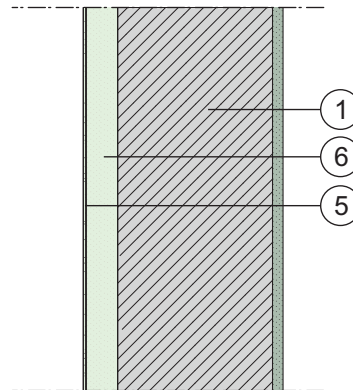

Vapour-retardant / -tight system with vapour-retardant / -tight board

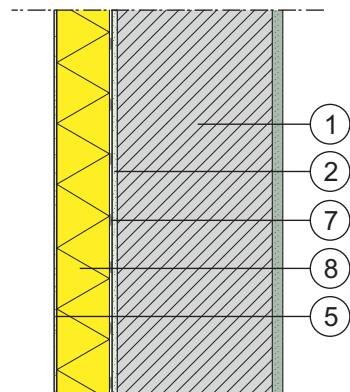

Vapour-retardant / -tight system with fibre mat and vapour barrier

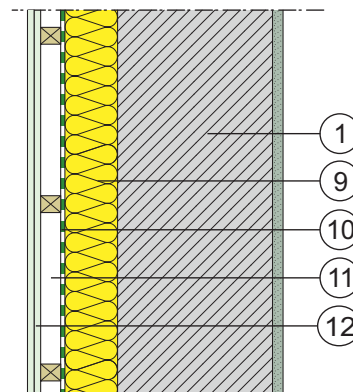

- 1 Existing masonry
- 2 Existing plaster or new leveling plaster
- 3 Adhesive mortar
- 4 Insulation board
- 5 Interior plaster / filler
- 6 Insulating plaster
- 7 Adhesive mortar, full-surface bonding is recommended
- 8 Vapour-tight or vapour-retardant insulation board
- 9 Fibre insulating board between battening
- 10 Vapour barrier
- 11 Batten level / air
- 12 Cladding, e.g. plasterboard, OSB

Overview of interior insulation variants

V1 to V4

Detail
0

IN2EuroBuild



Annex to the Guideline for Interior Insulation - Construction details

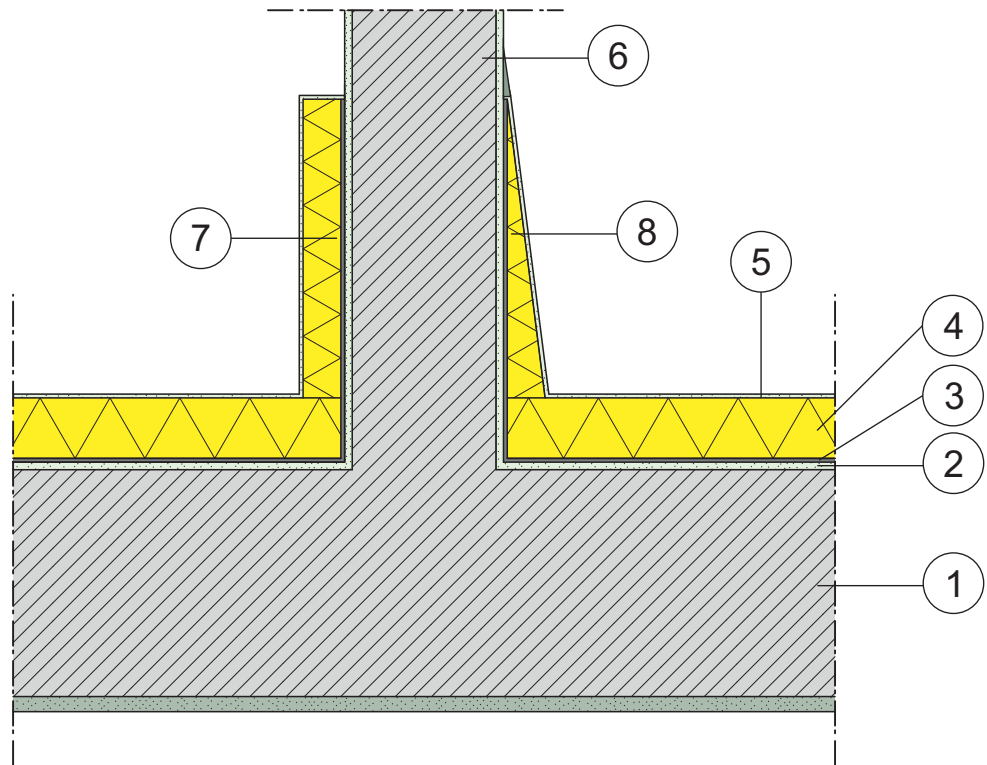

- 1 Existing masonry
- 2 Leveling plaster
- 3 Adhesive mortar
- 4 Insulation board
- 5 Vapour-permeable interior plaster / filler
- 6 Existing interior wall
- 7 Flank insulation, bonded, straight
- 8 Flank insulation, bonded, wedge-shaped

Integrating existing interior wall with straight or wedge-shaped flank insulation

V1 - Vapour permeable, capillary active interior insulation

Detail
1.1.1

IN2EuroBuild



Annex to the Guideline for Interior Insulation - Construction details

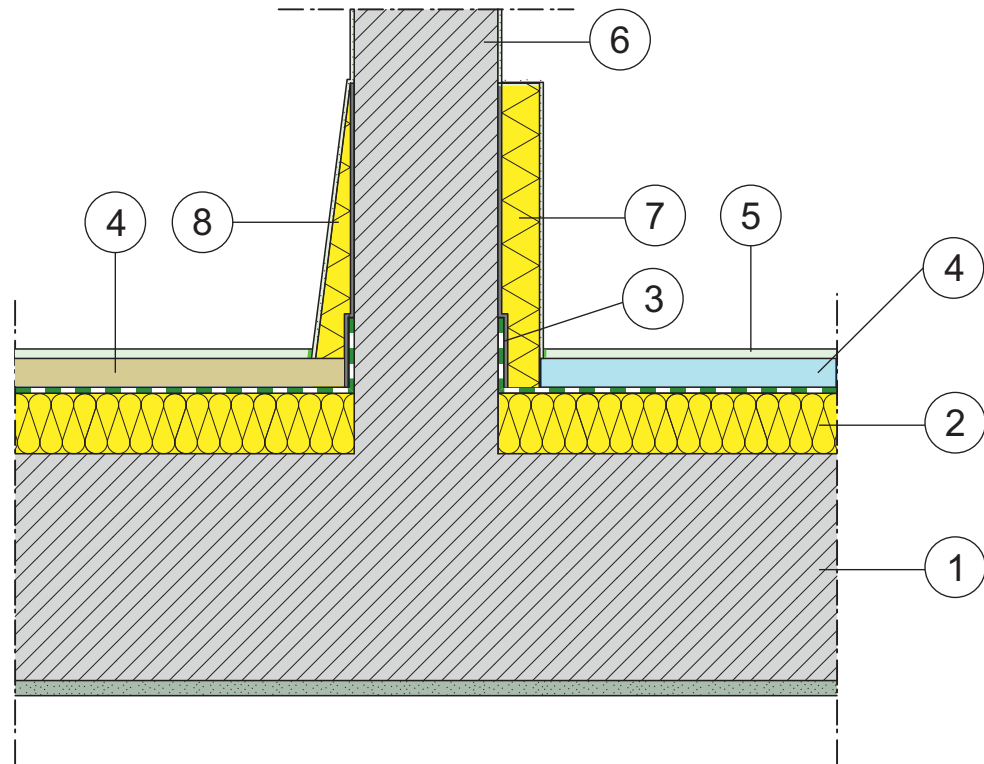

- 1 Existing masonry
- 2 Fibre insulating board between battening
- 3 Vapour barrier, with plaster joint tape
- 4 Batten level / air
- 5 Cladding, e.g. plasterboard, OSB
- 6 Existing interior wall
- 7 Flank insulation, bonded, straight
- 8 Flank insulation, bonded, wedge-shaped
- 9 Dividing strip

Integrating existing interior wall with straight or wedge-shaped flank insulation

V2 - Interior insulation with fibre mat and vapour barrier

Detail
1.1.2

IN2EuroBuild



Annex to the Guideline for Interior Insulation - Construction details

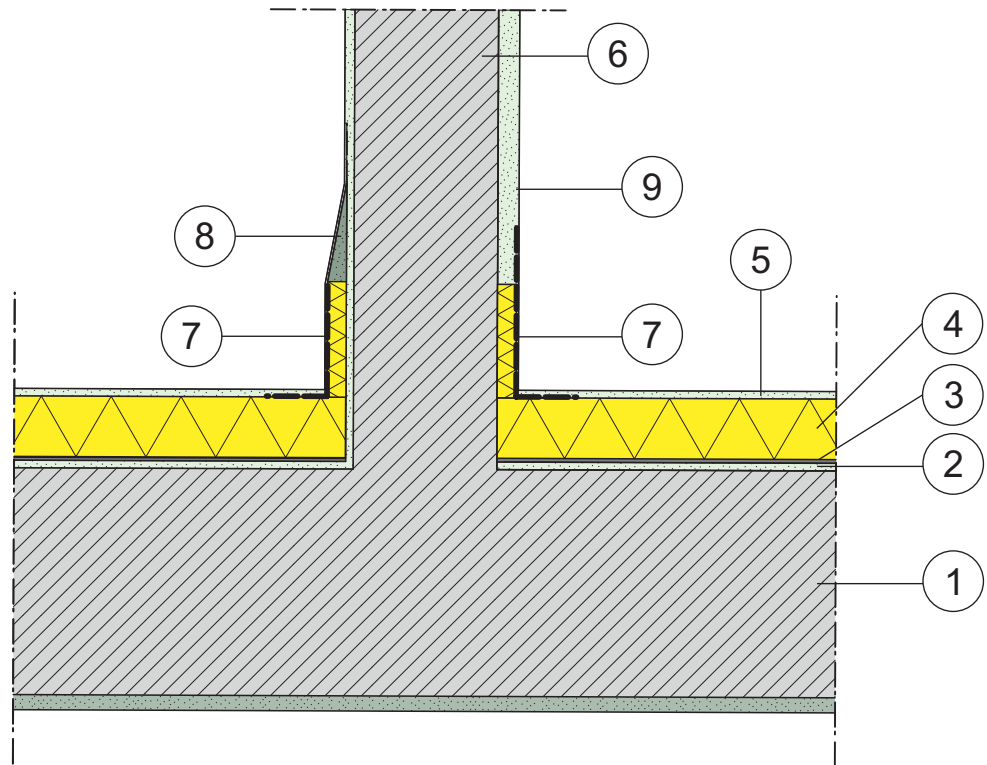

- 1 Existing masonry
- 2 Leveling plaster
- 3 Adhesive mortar
- 4 Insulation board
- 5 Vapour-permeable interior plaster / filler
- 6 Existing interior wall
- 7 Thermal conduction plate with insulation layer on the back
- 8 Coating tapering to existing plaster layer
- 9 Coating in level with existing plaster layer

Integrating existing interior wall connection with heat conduction plate

V1 - Vapour permeable, capillary active interior insulation

Detail
1.2.1

IN2EuroBuild



Annex to the Guideline for Interior Insulation - Construction details

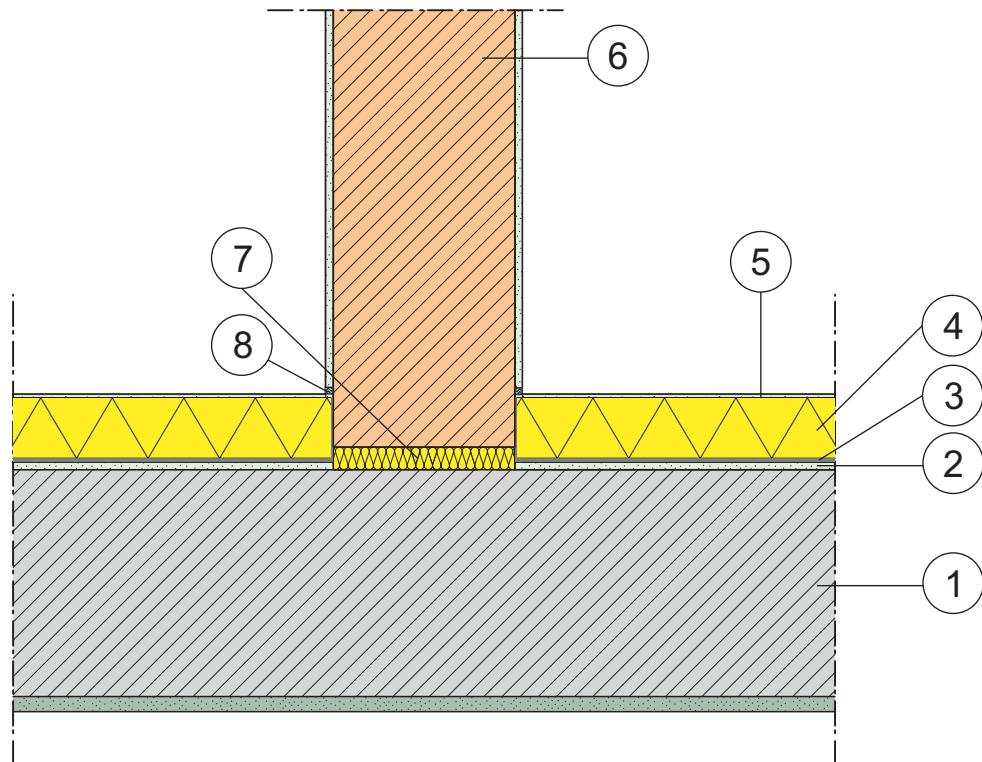

- 1 Existing masonry
- 2 Leveling plaster
- 3 Adhesive mortar
- 4 Insulation board
- 5 Vapour-permeable interior plaster / filler
- 6 New monolithic interior wall
- 7 Thermal separation, e.g. 3 cm mineral fibre
- 8 Joint tape, angle staff

Integrating new monolithic interior wall

V1 - Vapour permeable, capillary active interior insulation

Detail
1.3.1

IN2EuroBuild



Annex to the Guideline for Interior Insulation - Construction details

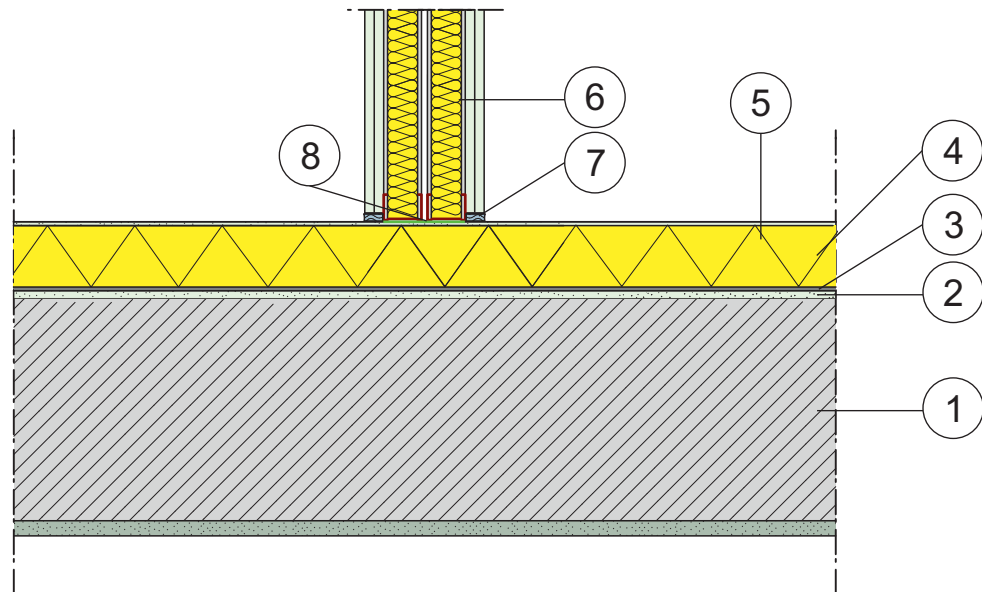

- 1 Existing masonry
- 2 Leveling plaster
- 3 Adhesive mortar
- 4 Insulation board
- 5 Vapour-permeable interior plaster / filler
- 6 New dry construction partition within a utilisation unit
- 7 Acrylic joint
- 8 Dry construction sealing tape

Connecting new dry construction partition (within a utilisation unit)

V1 - Vapour permeable, capillary active interior insulation

Detail
1.4.1

IN2EuroBuild



Annex to the Guideline for Interior Insulation - Construction details

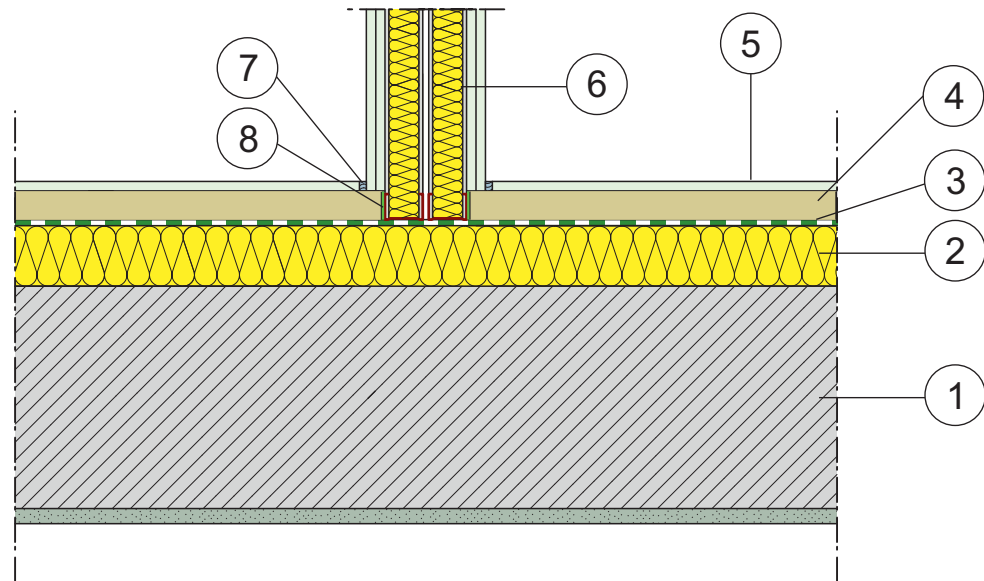

- 1 Existing masonry
- 2 Fibre insulating board between battening
- 3 Vapour barrier
- 4 Batten level / air
- 5 Cladding, e.g. plasterboard, OSB
- 6 New dry construction partition within a utilisation unit, depending on the connection situation, fixed to the floor and ceiling if necessary
- 7 Joint
- 8 Dividing strip

Integrating new dry construction partition (within a utilisation unit)

V2 - Interior insulation with fibre mat and vapour barrier

Detail
1.4.2

IN2EuroBuild



Annex to the Guideline for Interior Insulation - Construction details

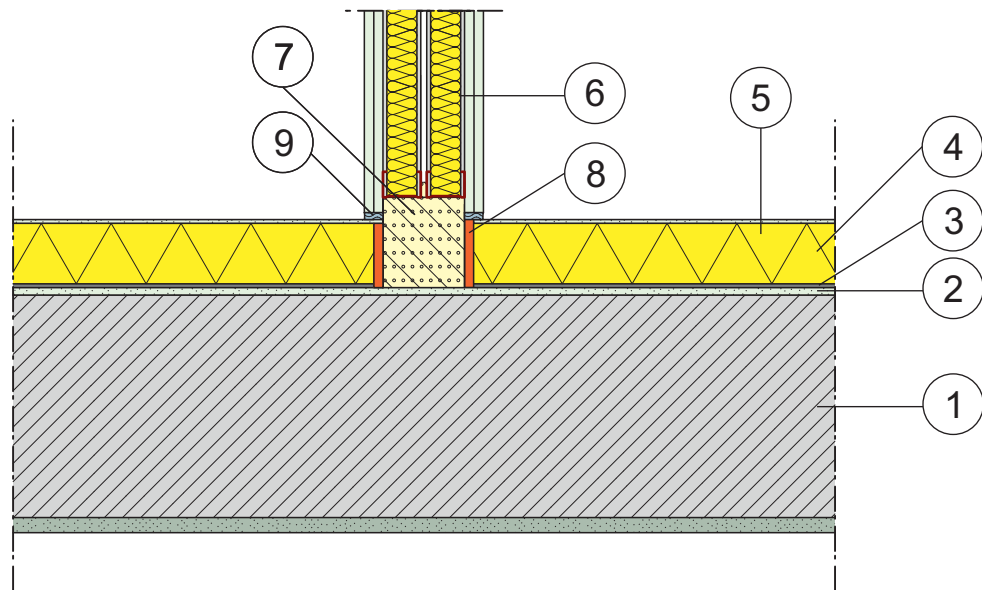

- 1 Existing masonry
- 2 Leveling plaster
- 3 Adhesive mortar
- 4 Insulation board
- 5 Vapour-permeable interior plaster / filler
- 6 New dry construction wall as a partitioning wall of an apartment
- 7 Offset block, e.g. lintel mounted vertically on the wall
- 8 Elastic separating layer / sealing tape between offset block and interior insulation
- 9 Connection joint

Integrating new dry construction wall (as partitioning wall)

V1 - Vapour permeable, capillary active interior insulation

Detail
1.5.1

IN2EuroBuild



Annex to the Guideline for Interior Insulation - Construction details

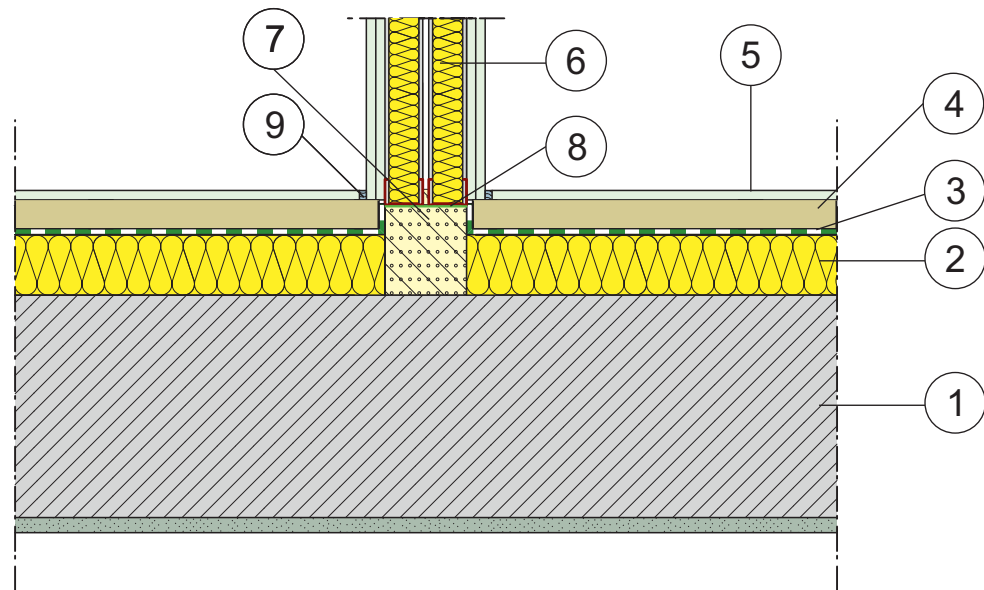

- 1 Existing masonry
- 2 Fibre insulating board
- 3 Vapour barrier with connection tape
- 4 Batten level / air
- 5 Cladding, e.g. plasterboard, OSB
- 6 New dry construction wall as partitioning wall of an apartment
- 7 Offset block, e.g. lintel mounted vertically on the wall
- 8 Dividing strip
- 9 Connection joint

Integrating new dry construction wall (as partitioning wall)

V2 - Interior insulation with fibre mat and vapour barrier

Detail
1.5.2

IN2EuroBuild



Annex to the Guideline for Interior Insulation - Construction details

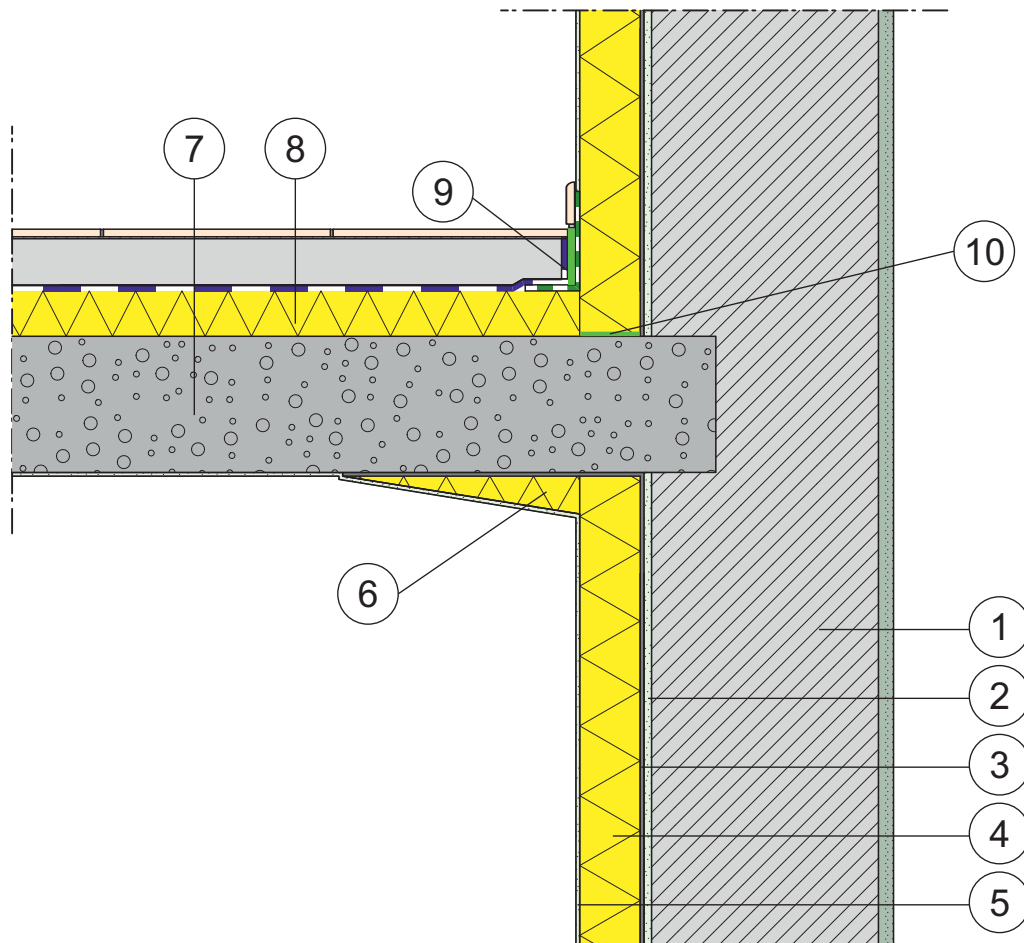

- 1 Existing masonry
- 2 Leveling plaster
- 3 Adhesive mortar
- 4 Insulation board
- 5 Vapour-permeable interior plaster / filler
- 6 Flank insulation (here as wedge-shaped insulation)
- 7 Existing ceiling
- 8 New floor construction
- 9 Edge insulation strip
- 10 Soundproof decoupling

Integrating existing solid ceiling with flank insulation

V1 - Vapour permeable, capillary active interior insulation

Detail
2.1.1

IN2EuroBuild



Annex to the Guideline for Interior Insulation - Construction details

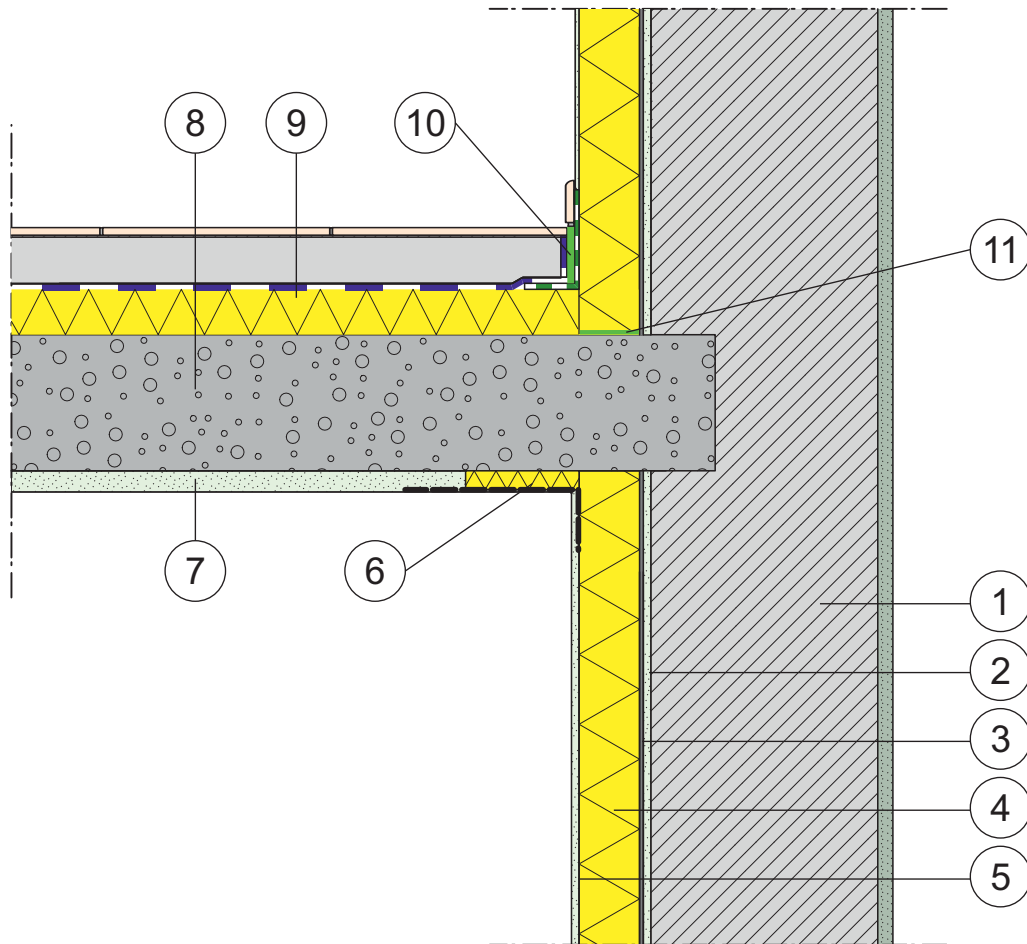

- 1 Existing masonry
- 2 Leveling plaster
- 3 Adhesive mortar
- 4 Insulation board
- 5 Vapour-permeable interior plaster / filler
- 6 Heat conducting plate with insulation layer on the back
- 7 Ceiling plaster, new
- 8 Existing ceiling
- 9 Floor construction, new
- 10 Edge insulation strip
- 11 Soundproofing decoupling

Integrating existing solid floor with heat conduction plate

V1 - Vapour permeable, capillary active interior insulation

Detail
2.2.1

IN2EuroBuild



Annex to the Guideline for Interior Insulation - Construction details

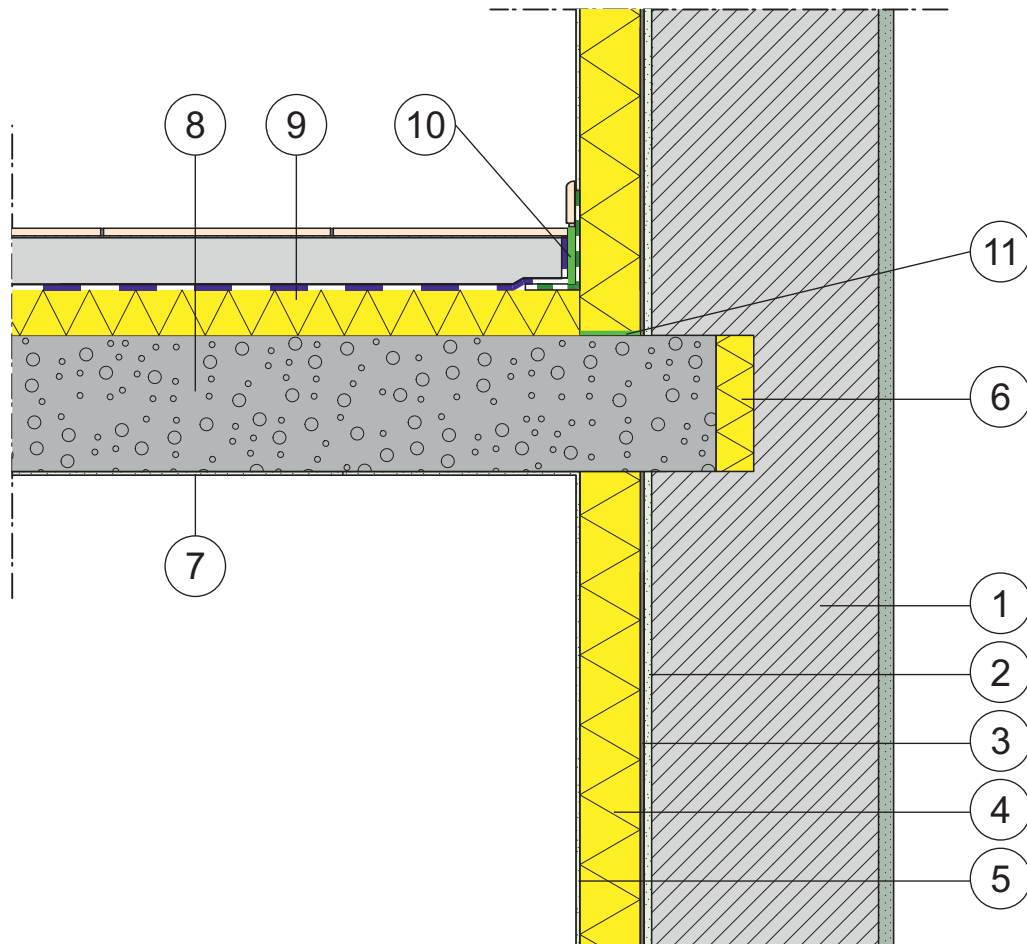

- 1 Existing masonry
- 2 Leveling plaster
- 3 Adhesive mortar
- 4 Insulation board
- 5 Vapour-permeable interior plaster / filler
- 6 Front side insulation, e.g. 5 cm EPS
- 7 New ceiling plaster / ceiling filler
- 8 New ceiling
- 9 New floor construction
- 10 Edge insulation strip
- 11 Soundproof decoupling

Integrating new solid ceiling with front side insulation

V1 - Vapour permeable, capillary active interior insulation

Detail
2.3.1

IN2EuroBuild



Annex to the Guideline for Interior Insulation - Construction details

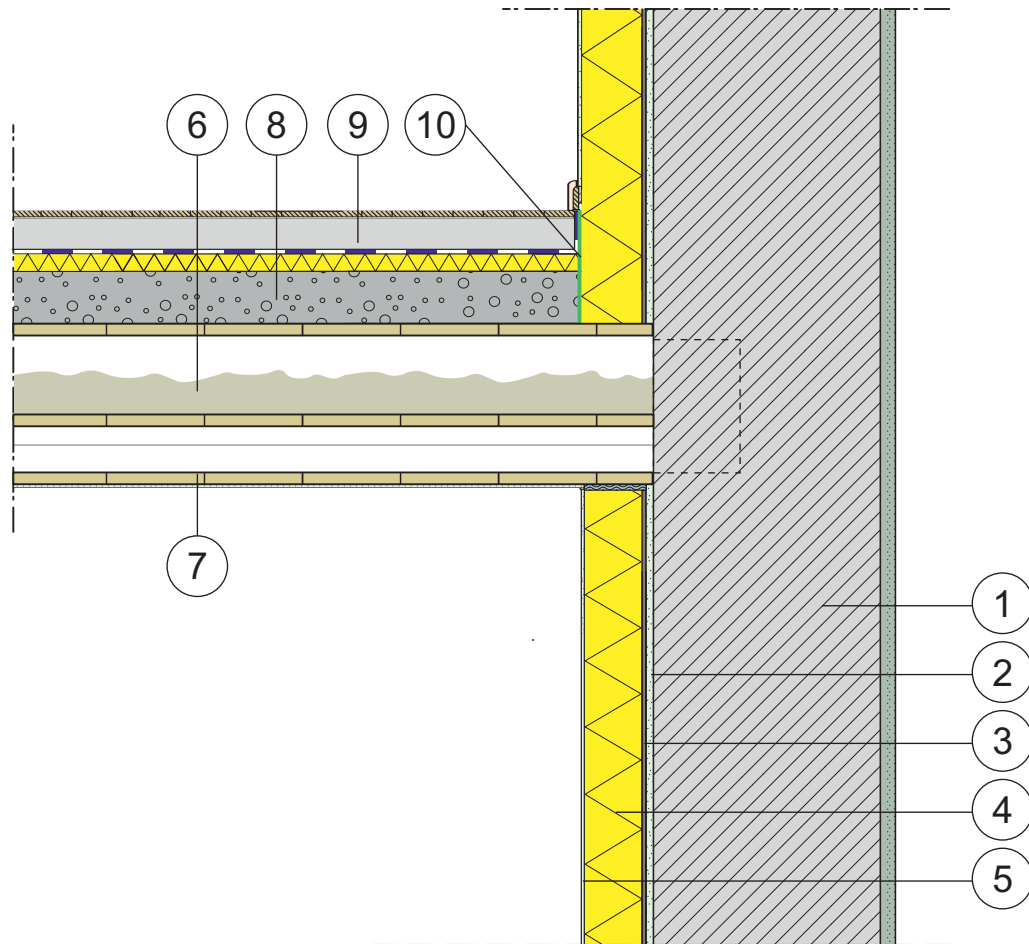

- 1 Existing masonry
- 2 Levelling plaster
- 3 Adhesive mortar
- 4 Insulation board
- 5 Surface filler / vapour permeable interior plaster
- 6 Existing timber ceiling with false floor and batten flooring
- 7 Existing suspended ceiling
- 8 Levelling fill
- 9 New floor construction with floating screed on soundproof decoupling
- 10 Edge insulation strip

Timber ceiling without opening the historical ceiling Midspan

V1 - Vapour permeable, capillary active interior insulation

Detail
2.4.1

Annex to the Guideline for Interior Insulation - Construction details

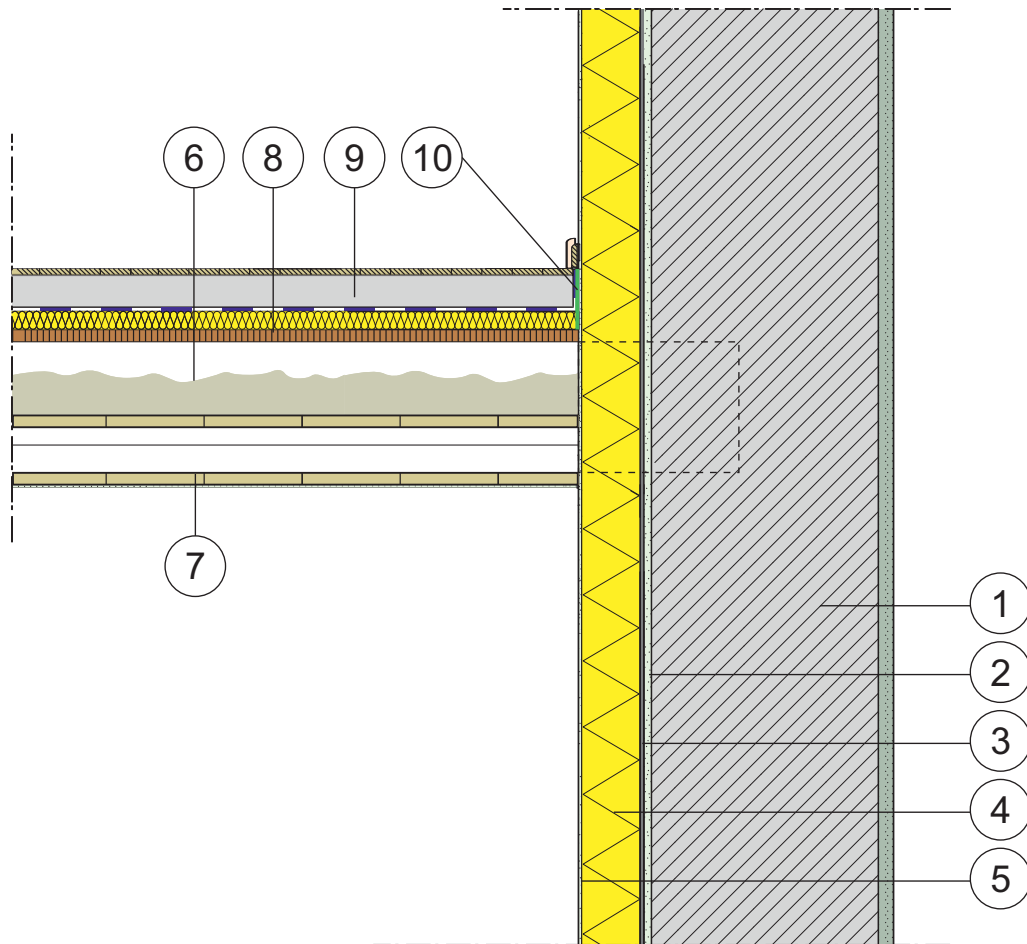

- 1 Existing masonry
- 2 Levelling plaster
- 3 Adhesive mortar
- 4 Insulation board
- 5 Surface filler / vapour permeable interior plaster
- 6 Timber beam ceiling partly dismantled, eventually new false floor with filling
- 7 Suspended ceiling new or adjusted
- 8 New OSB board
- 9 New floor construction with floating screed on soundproof decoupling
- 10 Edge insulation strip

Timber ceiling with opening of historical ceiling Midspan

V1 - Vapour permeable, capillary active interior insulation

Detail
2.5.1

Annex to the Guideline for Interior Insulation - Construction details

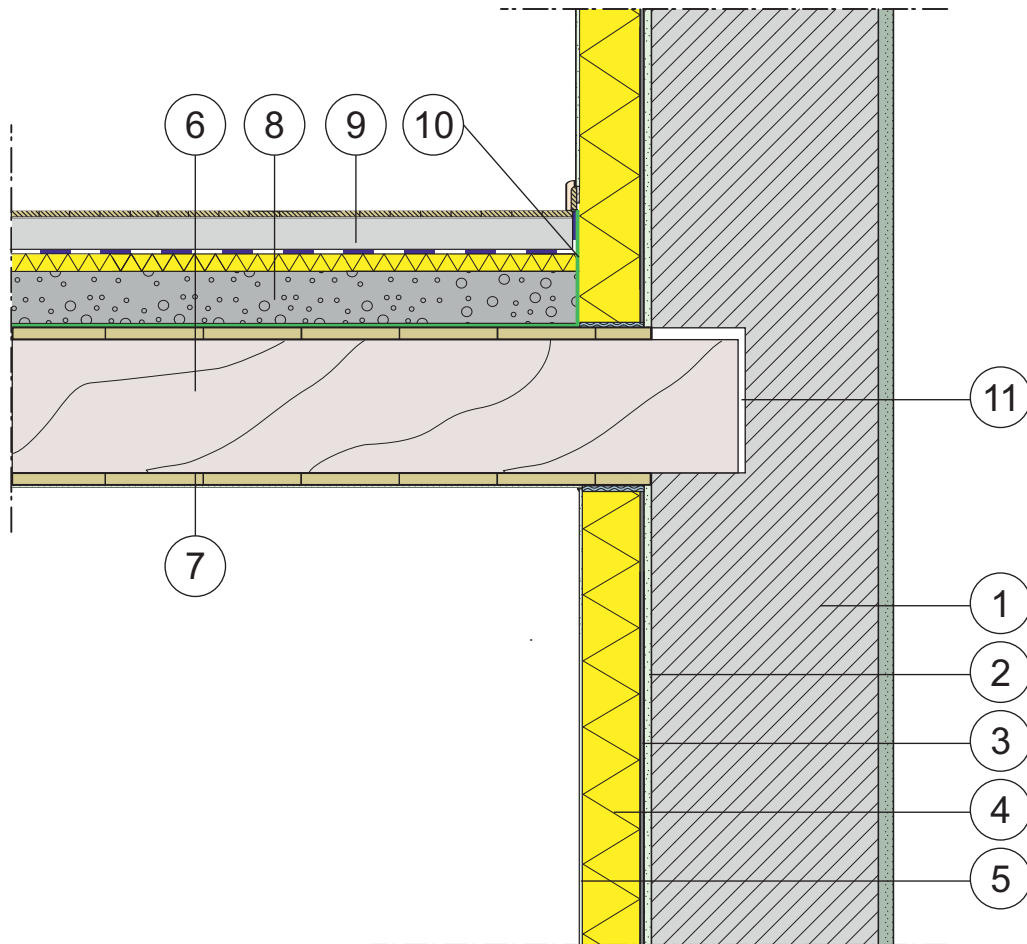

- 1 Existing masonry
- 2 Levelling plaster
- 3 Adhesive mortar
- 4 Insulation board
- 5 Surface filler / vapour permeable interior plaster
- 6 Existing timber beam ceiling with false floor and batten flooring
- 7 Existing suspended ceiling
- 8 Levelling fill
- 9 New floor construction with floating screed on soundproof decoupling
- 10 Edge insulation strip

Timber ceiling without opening of historical ceiling Cut through the beam

V1 - Vapour permeable, capillary active interior insulation

Detail
2.6.1

Annex to the Guideline for Interior Insulation - Construction details

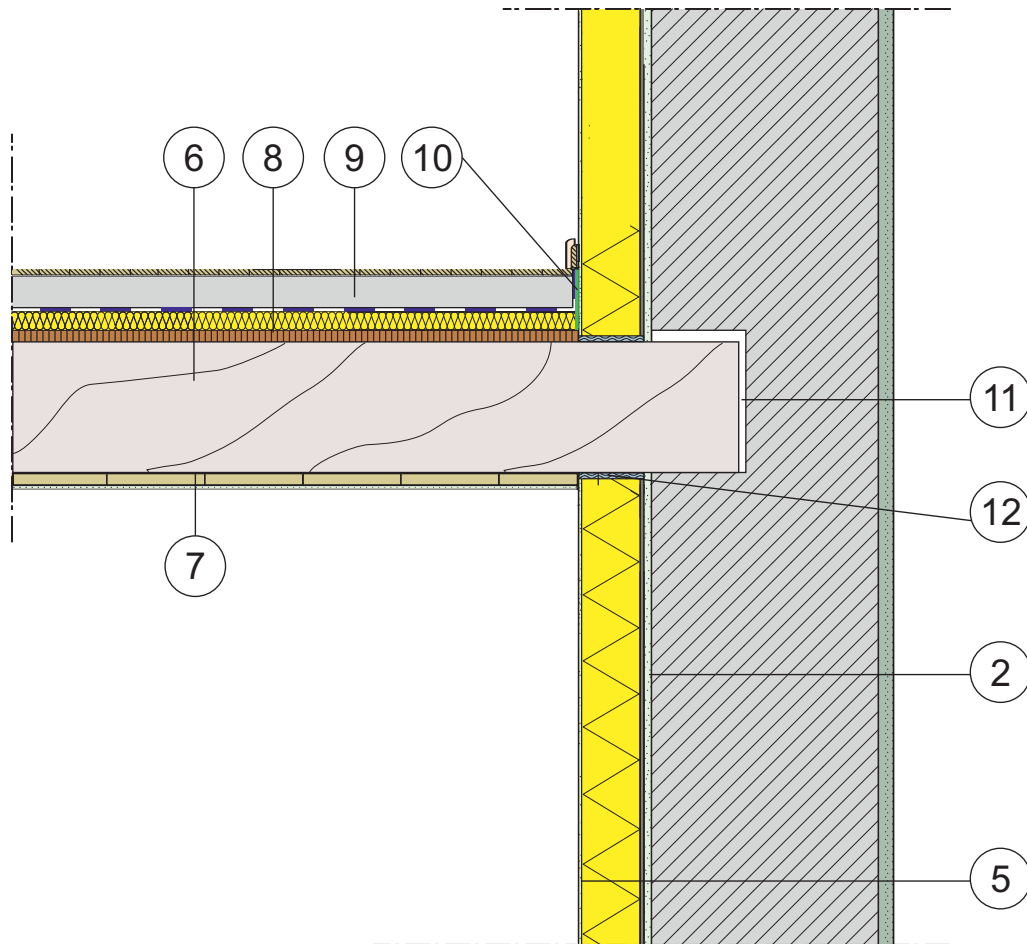

- 1 Existing masonry
- 2 Levelling plaster
- 3 Adhesive mortar
- 4 Insulation board
- 5 Surface filler / vapour permeable interior plaster
- 6 Timber beam ceiling partly dismantled, eventually new false floor with filling
- 7 New suspended ceiling or newly adjusted
- 8 New OSB board
- 9 New floor construction with floating screed on soundproof decoupling
- 10 Edge insulation strip
- 11 Cavity between joist end and masonry
- 12 Convection-inhibiting connection all around the beam

Timber ceiling with opening of the historical ceiling Cut through the beam

V1 - Vapour permeable, capillary active interior insulation

Detail
2.7.1

Annex to the Guideline for Interior Insulation - Construction details

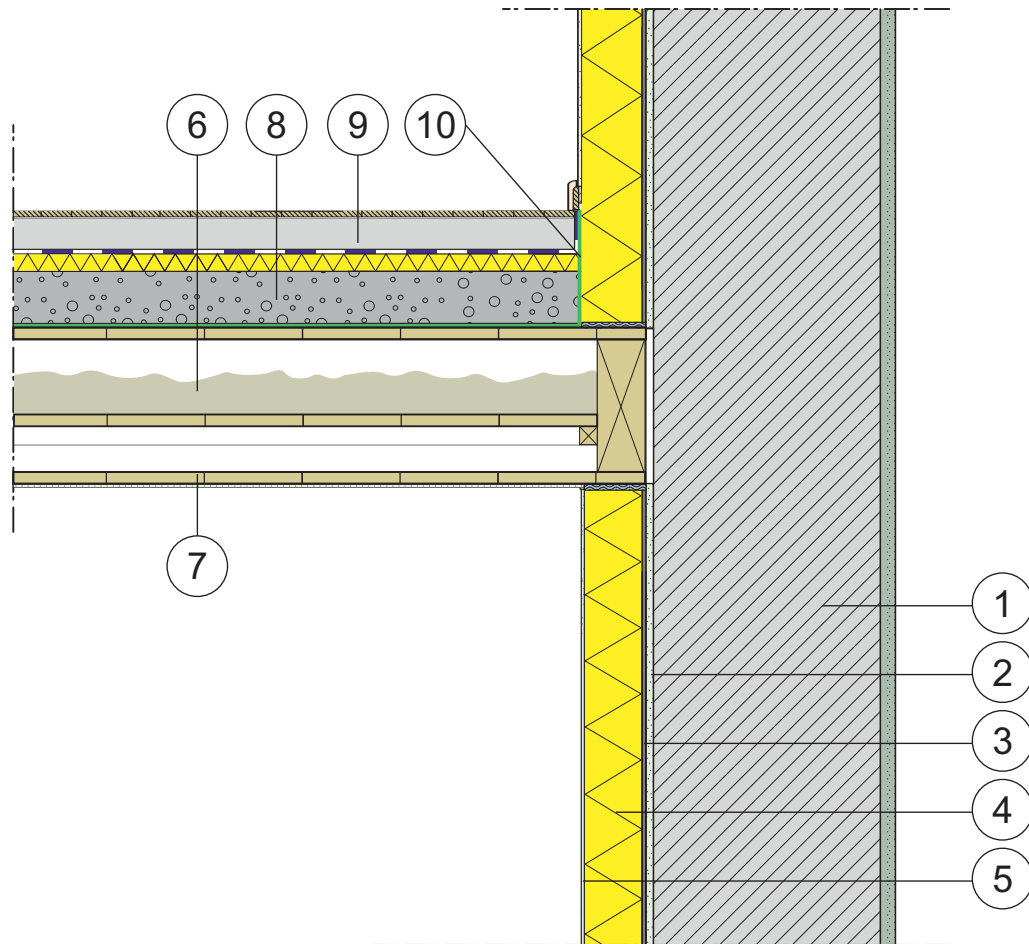

- 1 Existing masonry
- 2 Leveling plaster
- 3 Adhesive mortar
- 4 Insulation board
- 5 Surface filler / vapour permeable interior plaster
- 6 Existing timber ceiling with false floor and batten flooring
- 7 Existing suspended ceiling
- 8 Levelling fill
- 9 New floor construction with floating screed on soundproof decoupling
- 10 Edge insulation strip

**Timber ceiling without opening of the historical ceiling
Trimmer beam**

V1 - Vapour permeable, capillary active interior insulation

Detail
2.8.1

Annex to the Guideline for Interior Insulation - Construction details

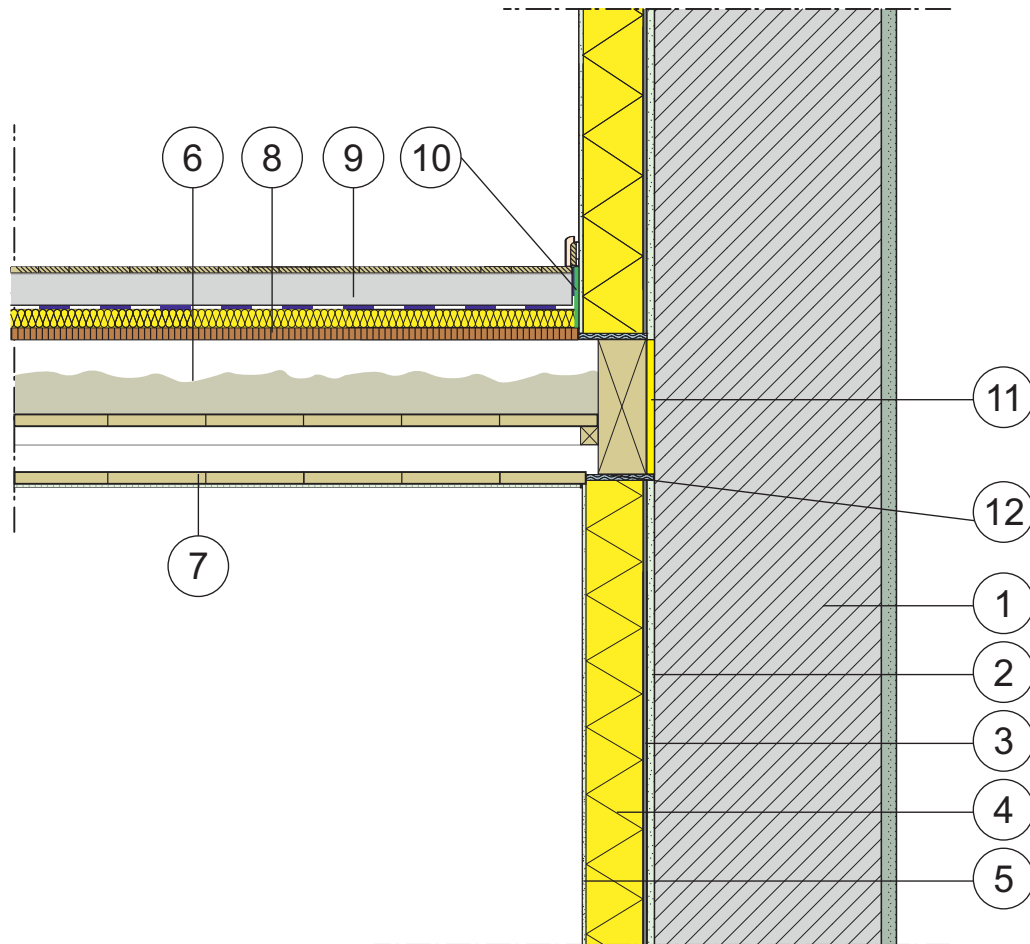

- 1 Existing masonry
- 2 Levelling plaster
- 3 Adhesive mortar
- 4 Insulation board
- 5 Surface filler / vapour permeable interior plaster
- 6 Timber beam ceiling partly dismantled, eventually new false floor with filling
- 7 New suspended ceiling or newly adjusted
- 8 New OSB board
- 9 New floor construction with floating screed on soundproof decoupling
- 10 Edge insulation strip
- 11 Vapour permeable insulation behind trimmer joist, if possible
- 12 Separating layer between interior insulation and trimmer beam

Timber ceiling with opening of the historical ceiling Trimmer beam

V1 - Vapour permeable, capillary active interior insulation

Detail
2.9.1

IN2EuroBuild



Annex to the Guideline for Interior Insulation - Construction details

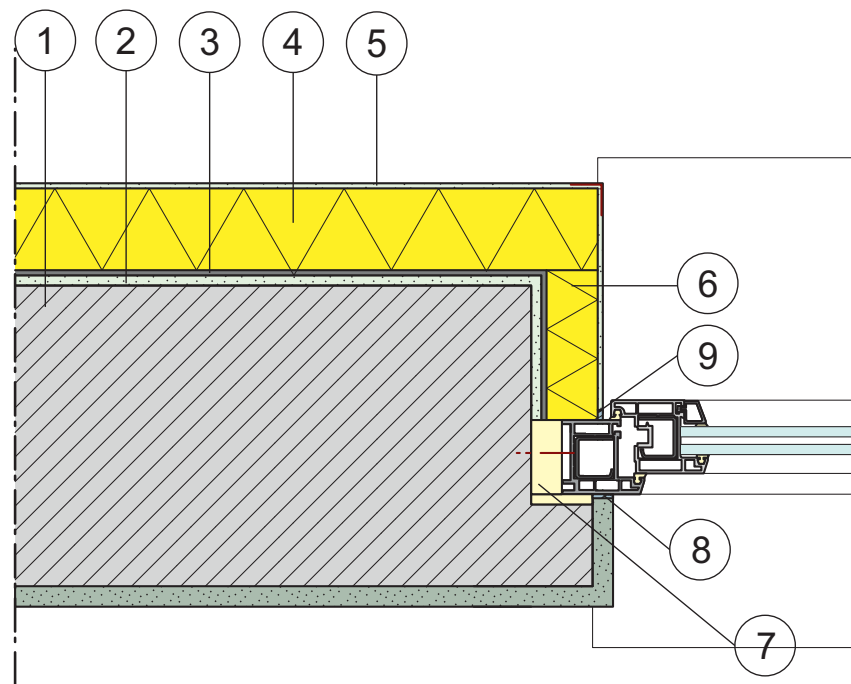

- 1 Existing masonry
- 2 Leveling plaster
- 3 Adhesive mortar
- 4 Insulation board
- 5 Vapour-permeable interior plaster / filler
- 6 Flank insulation
- 7 Insulation layer between window frame and masonry, e.g. PUR
- 8 Rain-proof joint, e.g. expanding strip, plastering strip
- 9 Connection tape, plastering strip

Window reveal with rabbet

V1 - Vapour permeable, capillary active interior insulation

Detail
3.1.1

IN2EuroBuild



Annex to the Guideline for Interior Insulation - Construction details

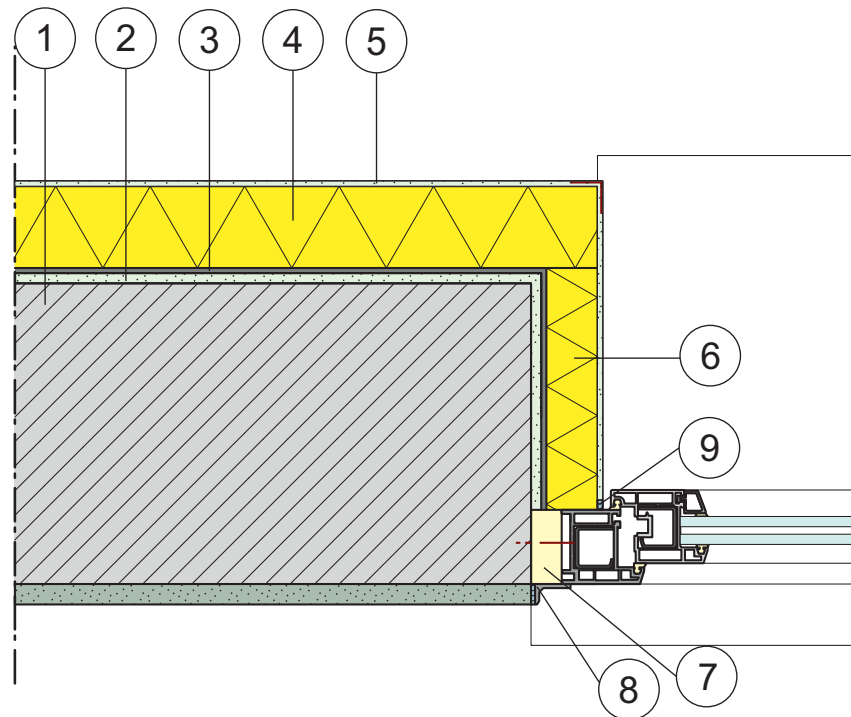

- 1 Existing masonry
- 2 Leveling plaster
- 3 Adhesive mortar
- 4 Insulation board
- 5 Vapour-permeable interior plaster / filler
- 6 Flank insulation
- 7 Insulation layer between window frame and masonry, e.g. PUR
- 8 Rain-proof joint, e.g. expanding strip, cover staff
- 9 Connection tape, plastering strip

Window reveal without rabbet Window in level with facade surface

V1 - Vapour permeable, capillary active interior insulation

Detail
3.2.1

Annex to the Guideline for Interior Insulation - Construction details

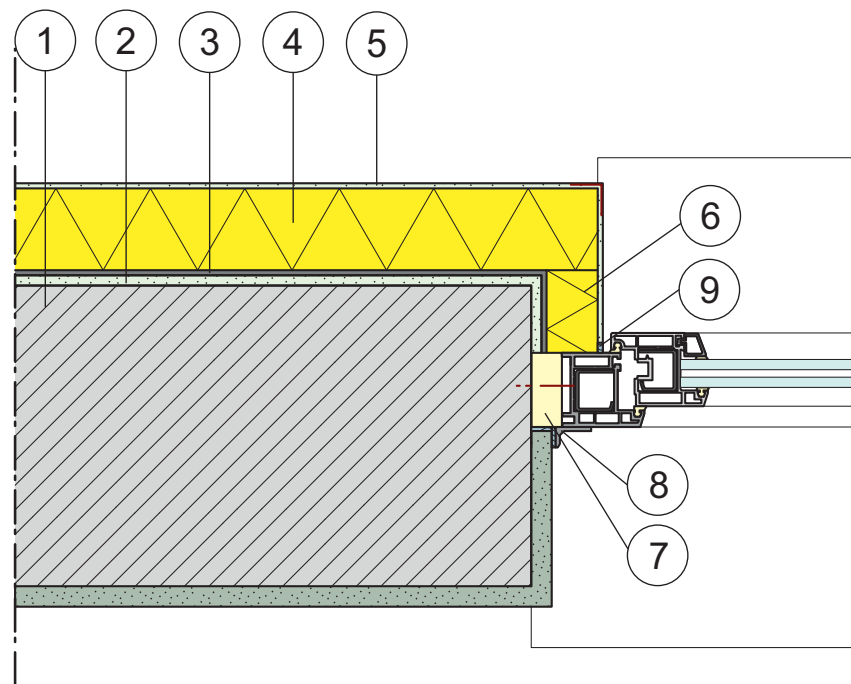

- 1 Existing masonry
- 2 Leveling plaster
- 3 Adhesive mortar
- 4 Insulation board
- 5 Vapour-permeable interior plaster / filler
- 6 Flank insulation
- 7 Insulation layer between window frame and masonry, e.g. PUR
- 8 Rain-proof joint, e.g. expanding strip, cover staff
- 9 Connection tape, plastering strip

Window reveal without rabbet Window in the centre of the wall

V1 - Vapour permeable, capillary active interior insulation

Detail
3.3.1

Annex to the Guideline for Interior Insulation - Construction details

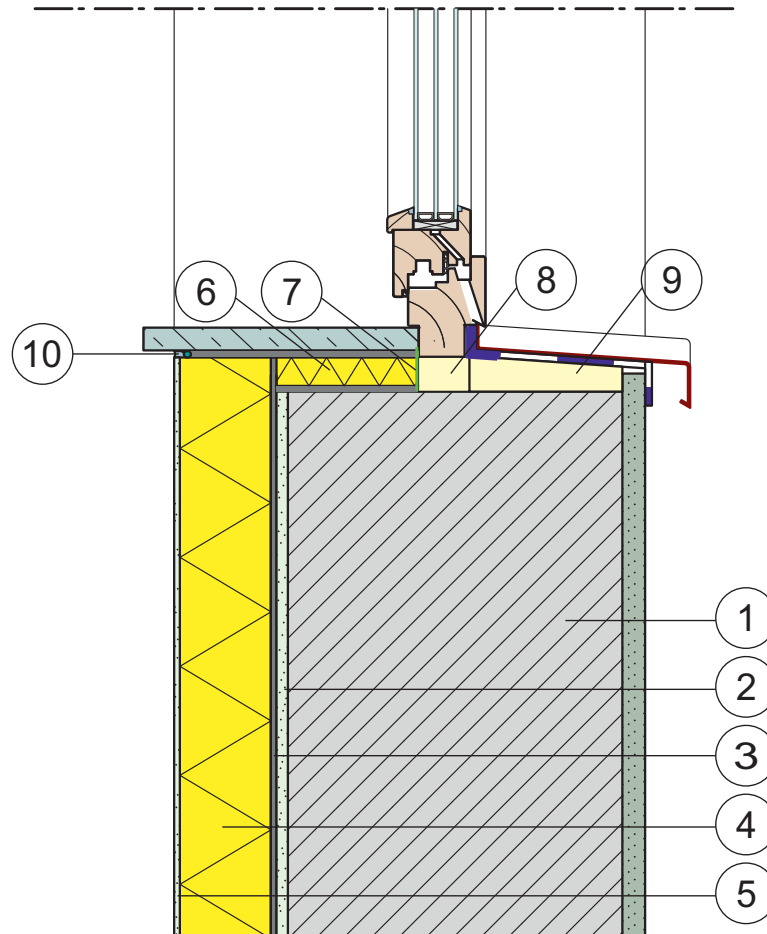

- 1 Existing masonry
- 2 Leveling plaster
- 3 Adhesive mortar
- 4 Insulation board
- 5 Vapour-permeable interior plaster / filler
- 6 Parapet insulation, e.g. 3 cm XPS
- 7 Connection tape
- 8 Insulation layer between window frame and masonry, e.g. PUR
- 9 Insulation layer under external window sill
- 10 Dividing strip, joint

Window breast Window in the centre of the wall

V1 - Vapour permeable, capillary active interior insulation

Detail
3.4.1

IN2EuroBuild



Annex to the Guideline for Interior Insulation - Construction details

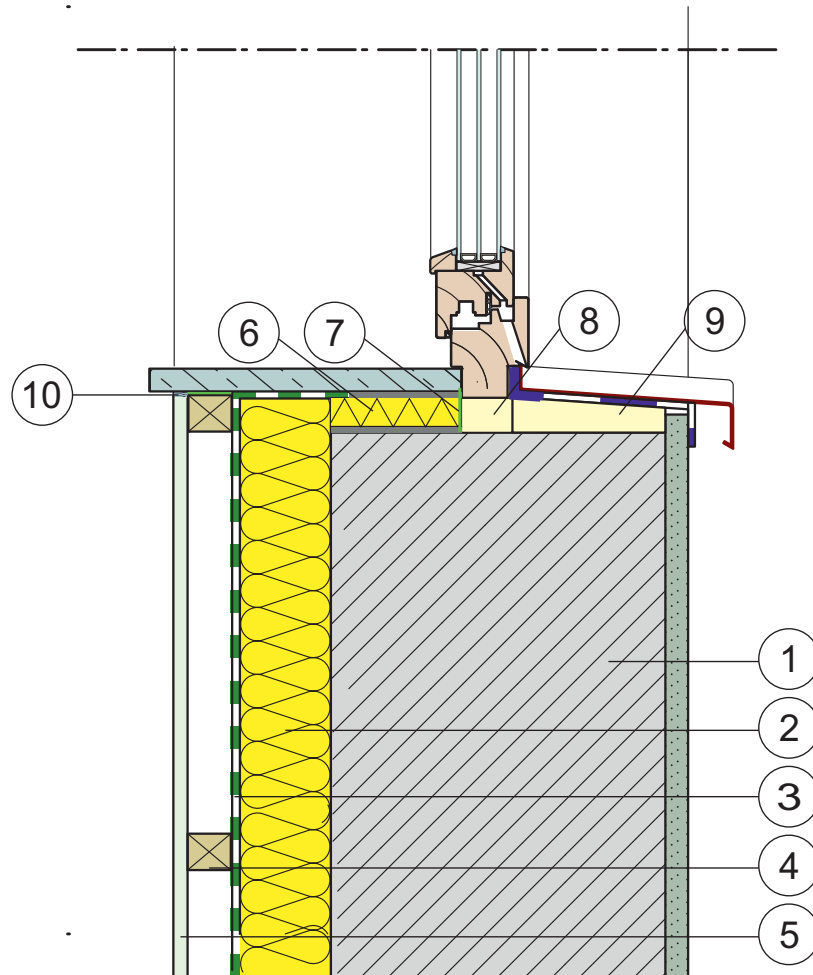

- 1 Existing masonry
- 2 Fibre insulating board between battening
- 3 Vapour barrier
- 4 Batten level / air
- 5 Cladding, e.g. plasterboard, OSB
- 6 Parapet insulation, e.g. 3 cm XPS
- 7 Connection tape
- 8 Insulation layer between window frame and masonry, e.g. PUR
- 9 Insulation layer under external window sill
- 10 Dividing strip, joint

Window breast Window in the centre of the wall

V2 - Interior insulation with fibre mat and vapour barrier

Detail
3.4.2

IN2EuroBuild – Consistent European Guidelines for Internal Insulation of Building Stock and Heritage



Facade renovation concept

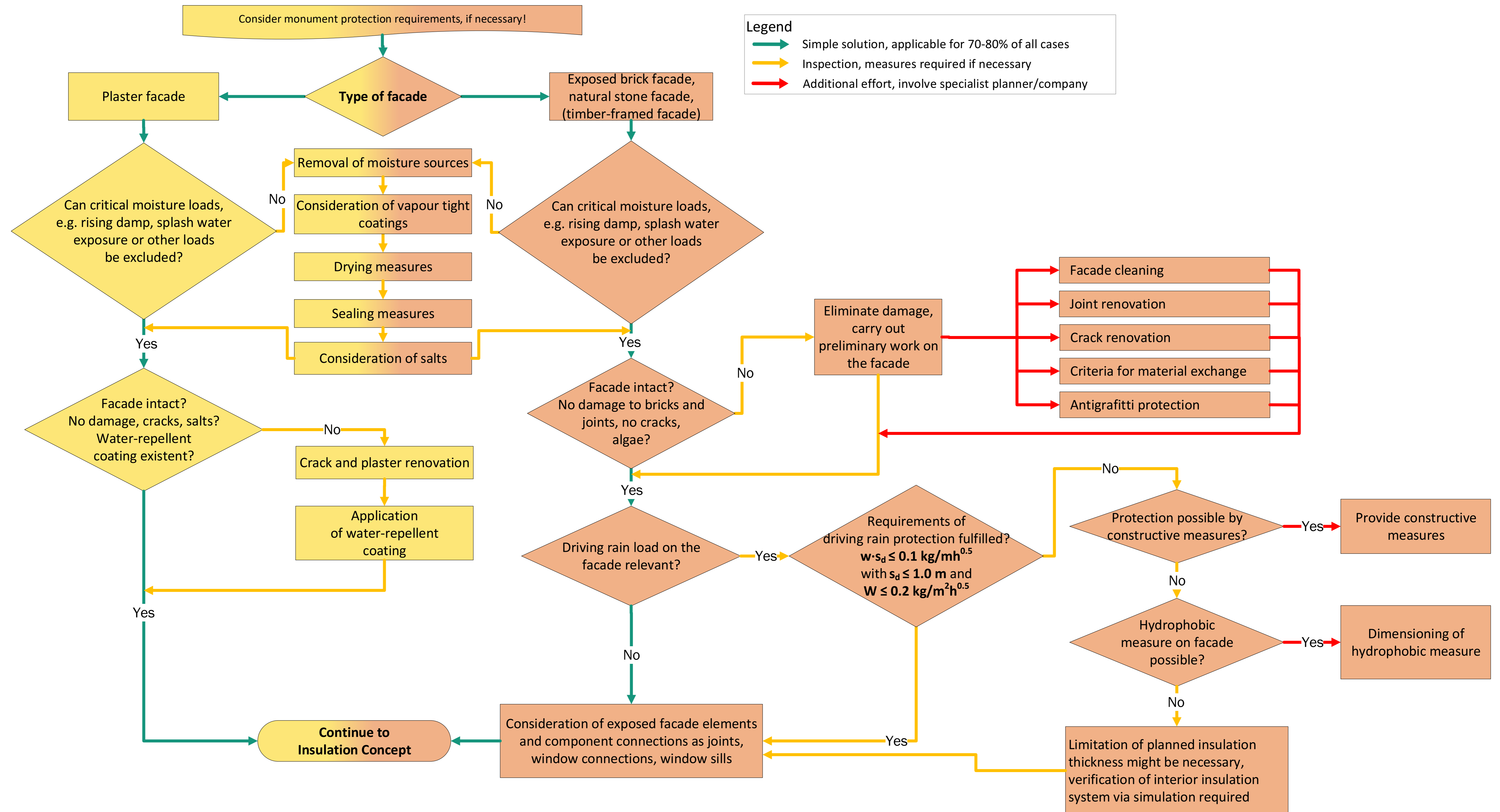

IN2EuroBuild – Consistent European Guidelines for Internal Insulation of Building Stock and Heritage



Insulation Concept

Determination of insulation standard
 - Minimum thermal insulation or high insulation level?
 - Overall renovation or individual measures?
 - Budget?
 - Utilization concept (e.g. with cellar or swimming pool?)

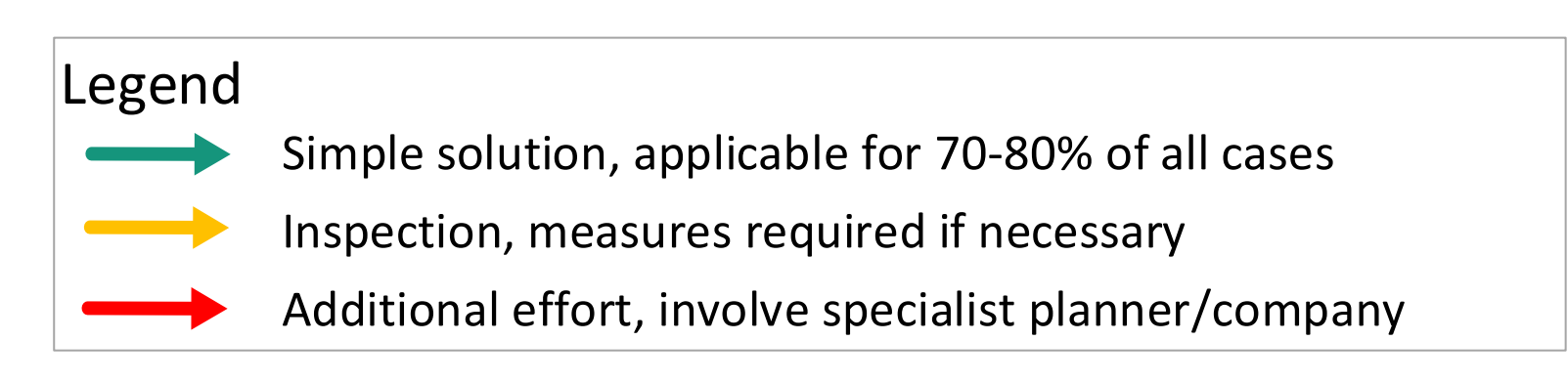
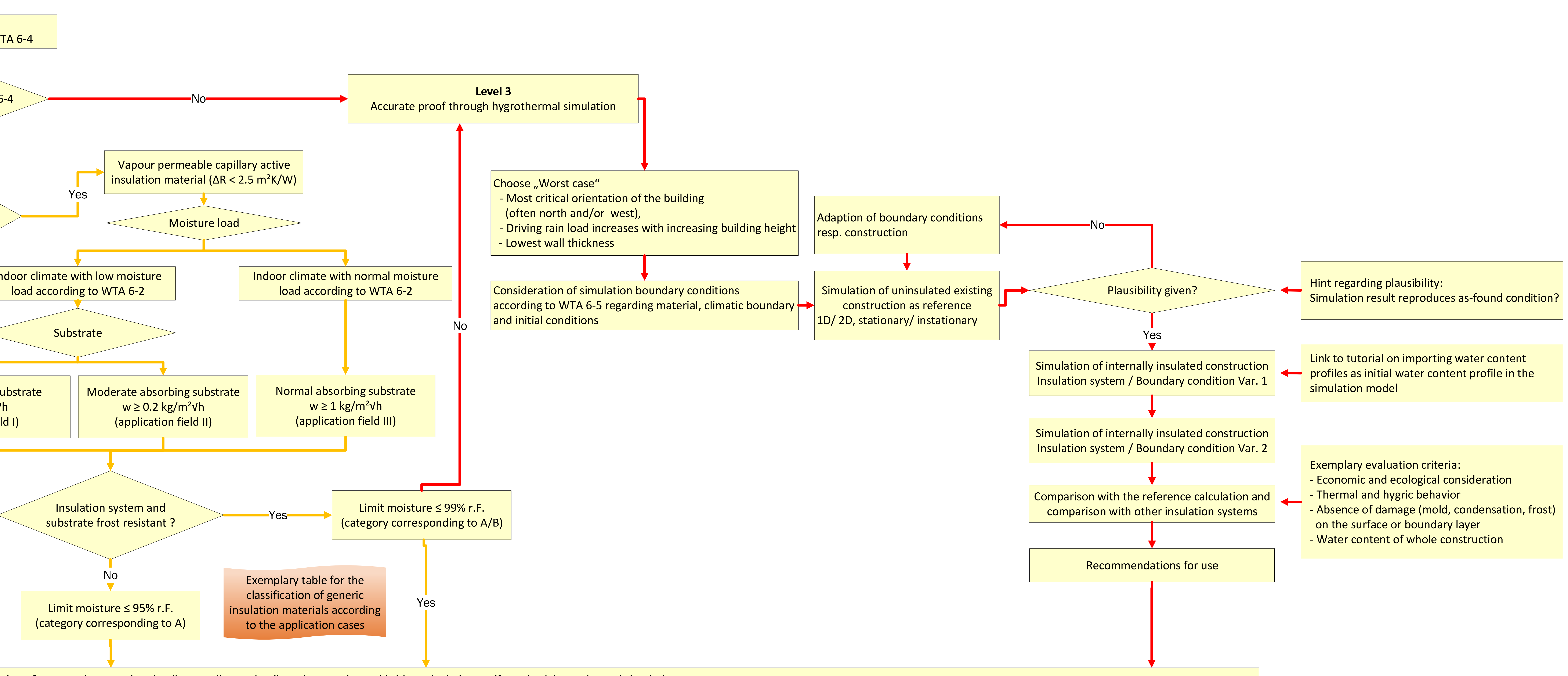
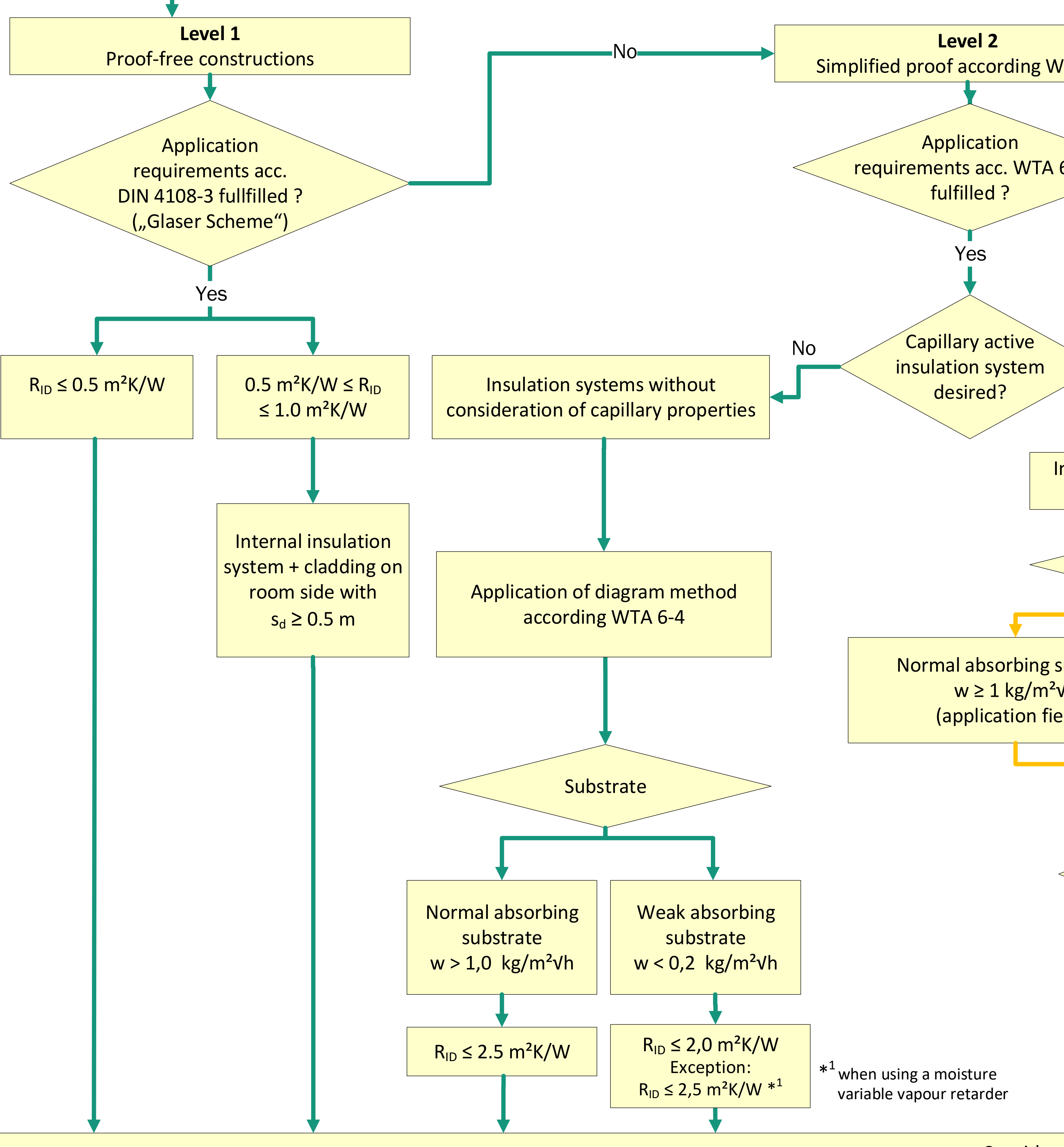
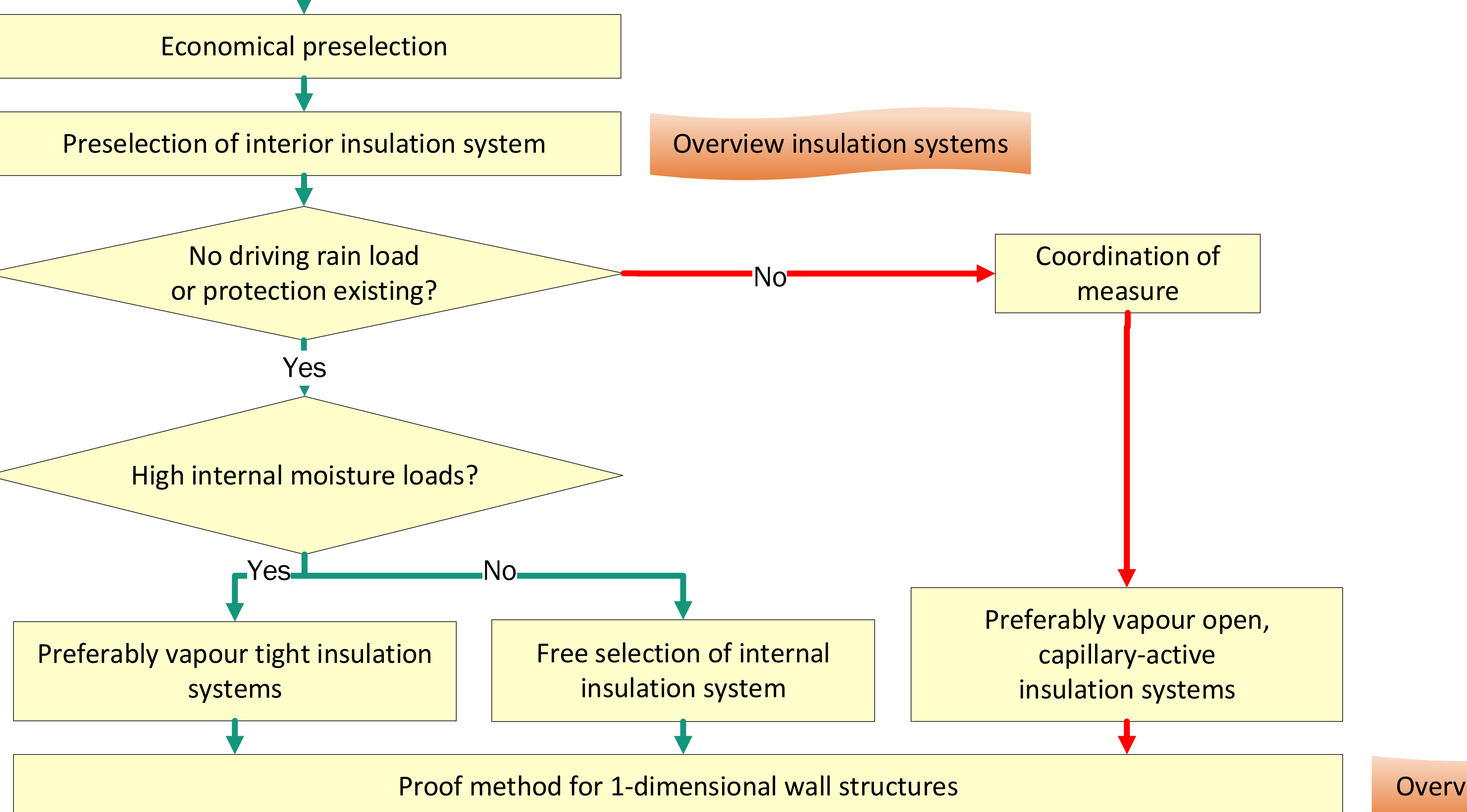
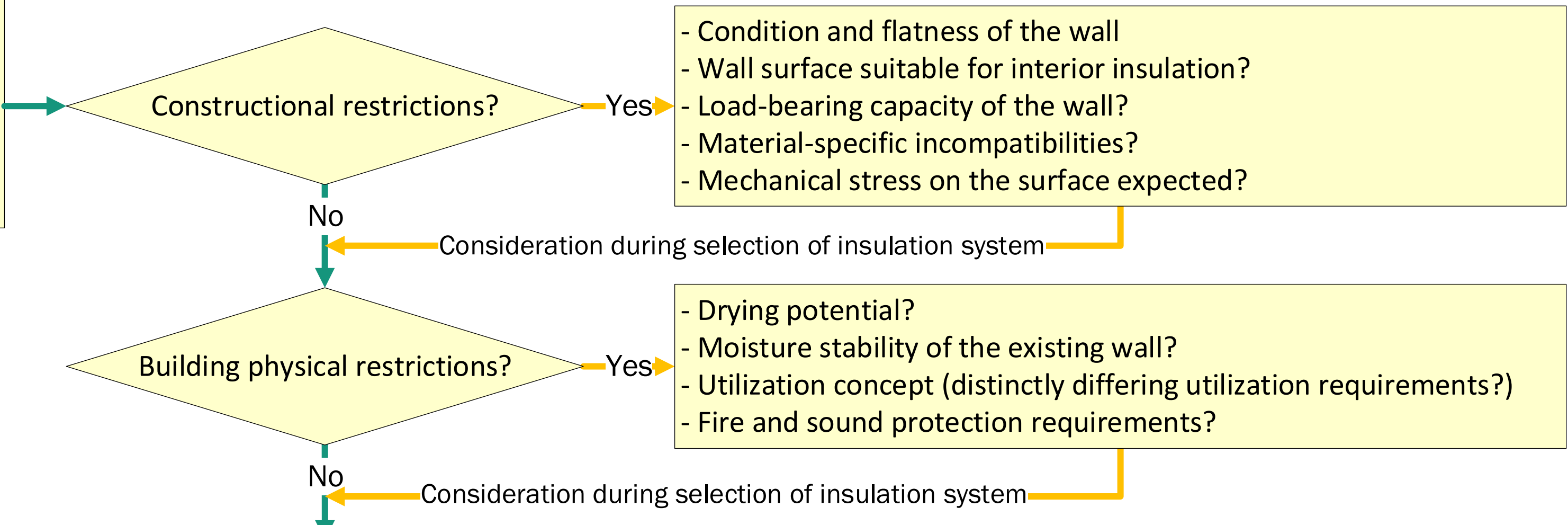

Consideration of structural connection details according to detail catalogues, thermal bridge calculation or, if required, hygrothermal simulation

