

ADECOS II

Advanced Development of the Coal-Fired Oxyfuel Process with CO₂ Separation*

A Research Project of the COORETEC Programme

S. Grahl, A. Hiller, J. Löser, S. Weigl, R. Wilhelm, M. Beckmann

Department of Combustion, Heat and Mass Transfer
Institute of Power Engineering
Technische Universität Dresden
Germany 01062 Dresden

*Further information can be found at the end of this paper.

Content

1 Abstract 3

2 Objectives 4

3 Research on Lignite 5

4 Flue Gas Treatment..... 13

5 About the ADECOS II Research Project..... 16

6 References..... 17

1 Abstract

In the future coal will still be the dominating resource for power generation, because of their availability at stable non-subsidised prices for many years and without strong dependence on exporting countries. As a second point, renewables cannot cover the great and permanently growing demand for energy in both the industrial and the newly industrialising countries. Efficiency enhancement of existing power plants on its own will not be enough to reach the ambitious targets until newer environment-friendly forms of energy conversion can replace coal-fired power plants. Therefore, climate protection as a public concern with the main objective to reduce CO₂ emissions requires the development of new energy concepts. From the facts above it becomes clear that coal-fired power plants with CO₂ separation could be an option and should be considered as a temporary technology on the way to a fully sustainable energy production. The so called *Oxyfuel* process with CO₂ separation is one of these technologies.

The basic principle is combustion of fossil fuels with pure oxygen, which results in a highly-concentrated CO₂ stream without nitrogen ballast compared to the conventional air-blown combustion. After further cleaning, the CO₂ will be ready for storage in a way that the climate is not affected.

The ADECOS (Advanced Development of the Coal-fired Oxylfuel Process with CO₂ Separation) project has the objective to make a comprehensive assessment of the *Oxyfuel* technology with CO₂ separation for coal. This includes experiments in laboratory and technical scale as well as theoretical investigation, modelling work and component design concerning:

- ignition and burn-out behaviour, fouling, slagging, NO reduction, start-up and shut-down behaviour, SO₂ removal, CO₂ separation by distillation, CFD modelling and validation at a 50 kW_{thermal} combustion chamber,
- comparison and evaluation of different steam generator concepts (pulverised fuel combustion, circulating fluidised bed combustion, melting chamber combustion),
- Evaluation of the overall *Oxyfuel* process (*EBSILON Professional*) and suggestions for optimisation, with special focus on intrinsic energy demand, residual gas separation, position of the desulphurisation facility as well as design of the steam generator and the compressor circuit for CO₂ compression.

In the presented paper we will focus on the experimental results at the test facilities at the University of Technology Dresden.

2 Objectives

The ADECOS project is formed by nine partners – three power plant operators, three manufacturers of power plant components and three universities – and is structured into seven work packages to achieve the ambitious goals. The specific tasks of each work package are shared between two or more partners in most cases. The research project aims to push the *Oxyfuel* process for lignite and hard coal in terms of its operational capability for the large power plant engineering with regard to process engineering, plant technology and economy by examining and developing in these aspects. The project ADECOS II should further develop the basics of the *Oxyfuel* process through experimental and theoretical studies. This is of fundamental importance, since general knowledge and information must be provided. This relates the experimentally validated basis for the simulation of heat and mass transport for different furnaces and fuels, combustion parameters, process dynamics, design principles for *Oxyfuel* steam generators, design recommendations and design bases for the flue gas and CO₂ treatment chain, systems analysis as well as system development of the *Oxyfuel* process. The still existing uncertainties about the level of allowable impurities in the separated CO₂ require the systematic examination of all possible cleaning methods because of the plant-specific and energetic effort in the case of extremely low impurity limits and thus their disproportionately increase. There is a high need for research to reduce significantly the risk for realization on a large industrial scale. Similarly, previous studies have shown that the mapping and analysis of the *Oxyfuel* process chain as a whole only leads to realistic results, if theoretical boundary conditions are backed by validated or replaced data. This data should therefore be provided by fundamental studies which are made available by the project.

3 Research on Lignite

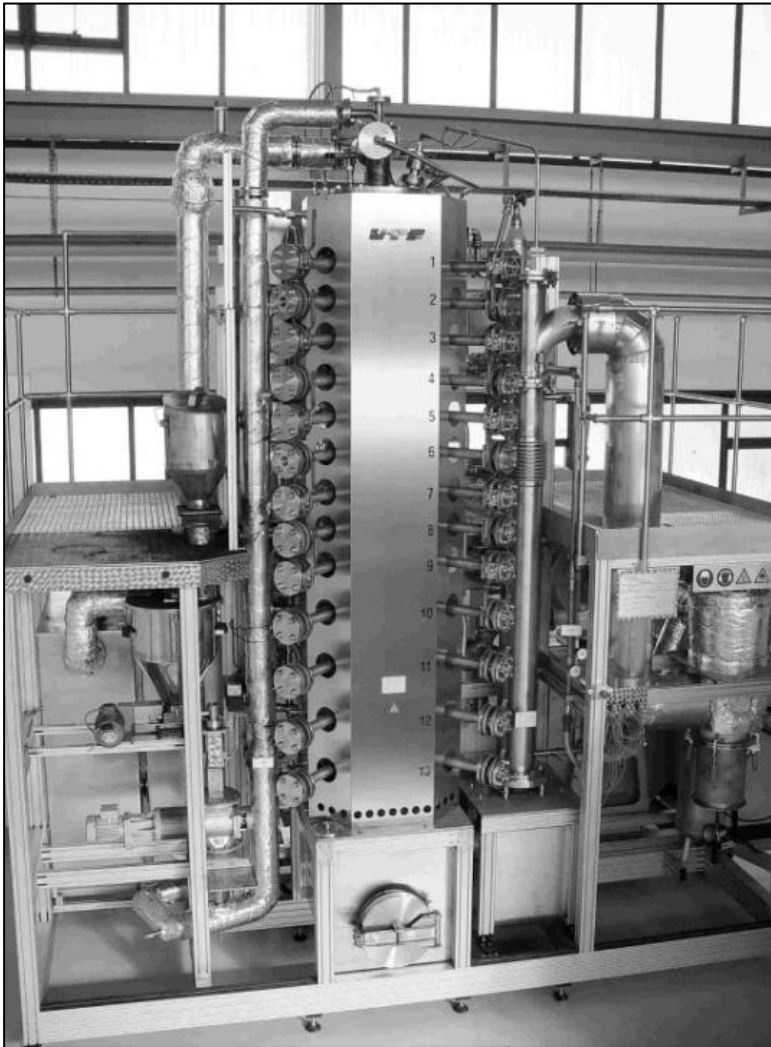

Figure 1: Pulverised Coal Combustion Test Facility at University of Technology Dresden

The 50 kW Pulverised Coal Combustion test facility (Figure 1) provides the option for investigations into *Oxyfuel* combustion and additionally in air-combustion. From the investigations, the tendencies concerning the emission behaviour in different operational conditions can be derived.

The test facility has a thermal power of 50 kW_{therm} and alongside the conventional operational mode with air are different options possible. It also allows coal combustion with pure oxygen and recirculation of flue gas (*Oxyfuel*) to be investigated.

After the combustion chamber (#1 in Figure 2), the cooling (#3) of the flue gas occurs at about 200 °C and the filtration (#4) of the fly ash takes place. Then a fan (#5) recirculates a part of the flue gas and this is divided into a certain proportion of primary (#7) and secondary

(#8) recirculation. The primary flue gas stream aids to the conveyance of the fuel (#10). In the secondary flue gas stream the oxygen (#6) required for the combustion is added in a premix chamber of the burner (#2). The test facility is almost absolutely gas-tight and can represent an ideal *Oxyfuel* process. That means, in dry flue gas conditions carbon dioxide concentrations well over 95 % can be measured. Through defined adding of in-leaked air (*false air*), a close to reality *Oxyfuel* process can be investigated.

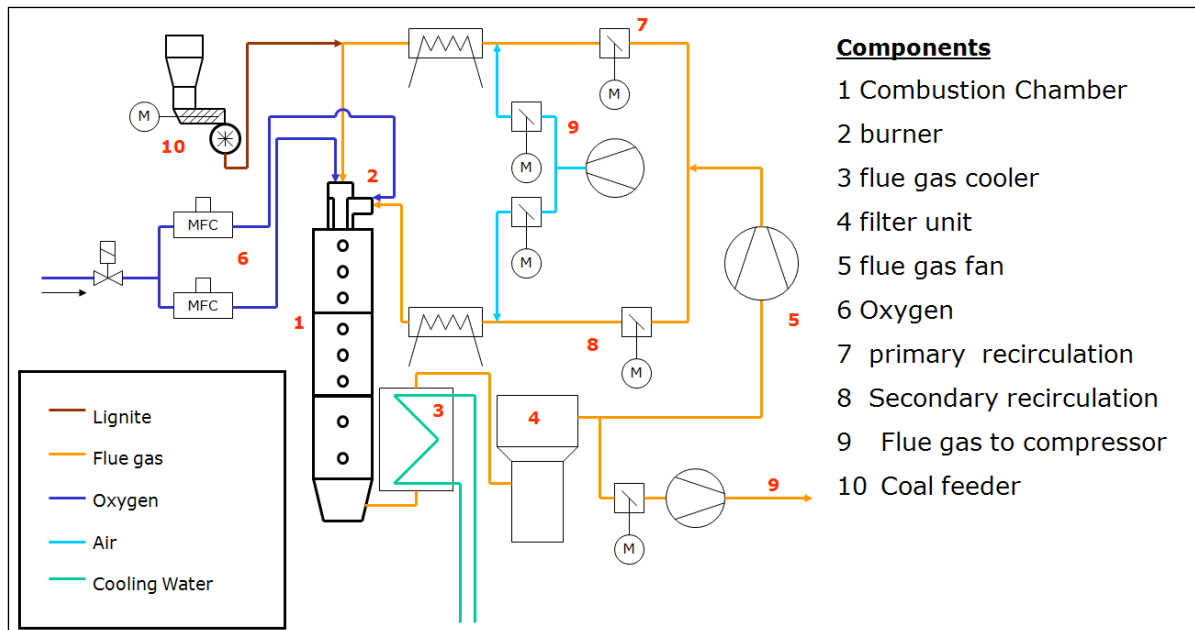

Figure 2: Process diagram of the Pulverised Coal Combustion test facility

The flue gas composition at the end of the combustion chamber is measured through conventional exhaust gas measuring techniques that are infrared based. With that, a partial flow stream is sucked, dried and analysed.

The flue gas parameters are obtained by suction of gas from the combustion chamber in different heights, but also along the cross-section through a special sensor. The probe has a gas-tight connection so that no air in-leakage occurs while measuring. The analysis took place with both the use of measuring equipment and the help of the project partner, the University of Applied Sciences Zittau-Gorlitz.

In order to closely determine the reaction conditions in the flame region, a temperature measurement with a suction pyrometer after VDI/DE 3511 at different positions in the cross-section of the combustion chamber was carried out. At the same depth in different port openings alongside the combustion chamber, particle samples were withdrawn, which were further analysed in the laboratory specifically in terms of the burnout and elementary composition.

The *Oxyfuel* process can be entirely described through the two oxygen concentrations at combustion chamber entry and exit. Initially a certain amount of oxygen is fed based on the global stoichiometry necessary for good burnout in coal-firing. The oxygen concentration at the entry of the combustion chamber is then adjusted by the amount of the recirculated flue gas – thereby *Oxyfuel 25* means that 25 percent by volume oxygen is preset at the burner head. Therefore *Oxyfuel 17* has a higher recirculation rate than *Oxyfuel 33* because of the dilution effect from the water and CO₂ rich flue gas stream that is recirculated. The targeted excess oxygen at the end of the combustion chamber thus in turn defines the amount of oxygen that must be fed. Inleakage air (false air) is added before the recirculated gas stream enters the combustion chamber and is considered as an additional oxygen entry. For the characteristic experiments, the recirculation amount was varied at constant excess oxygen concentration.

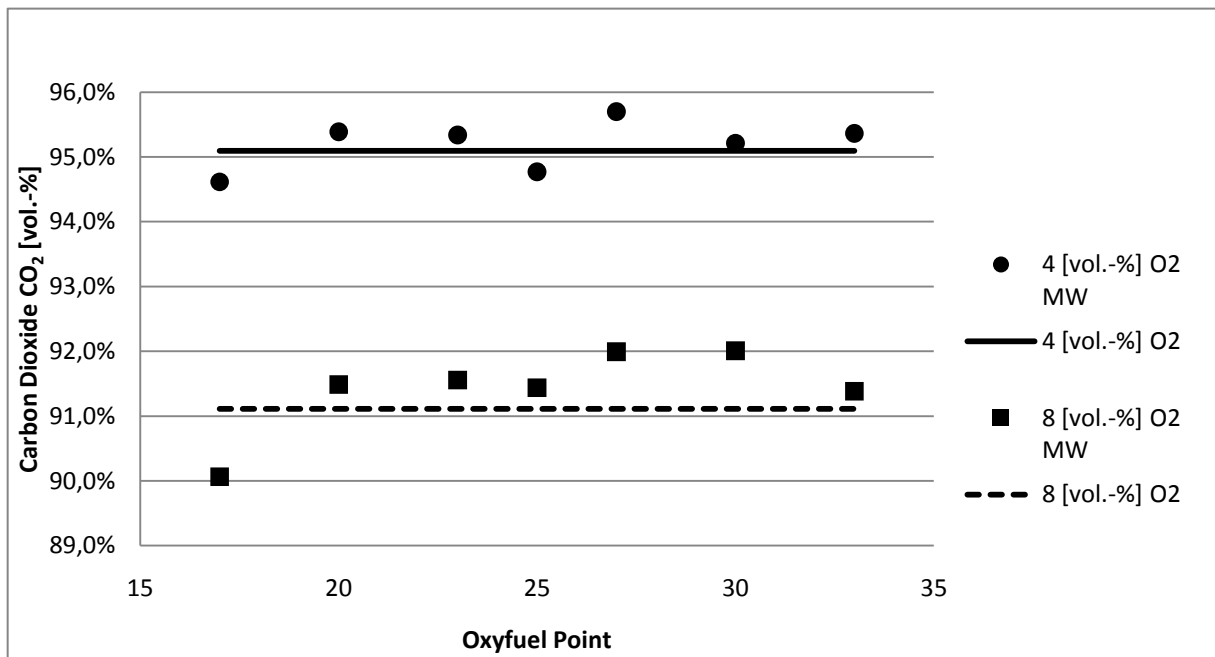

Figure 3: CO₂ concentration in the *Oxyfuel* flue gas stream dependent on the excess oxygen

Based on a mathematical model [1], the expected carbon dioxide concentrations for different *Oxyfuel* points by varying excess oxygen at the end of the combustion chamber have been calculated. In Figure 3 the expected values (lines) are shown for two cases (4 vol.-% and 8 vol.-%). No matter how much of the exhaust gas is recirculated, the concentration of CO₂ in the flue gas for a homogeneous fuel is only dependent on the residual oxygen at the end of the combustion chamber, which in turn can be defined by the global oxygen feed.

The values represented by points are measured values (MW). With the Pulverised Fuel

Combustion test facility at the University of Technology Dresden, the balance points can be approached very accurately. Values of around 95 vol.-% carbon dioxide in dry flue gas at 4 vol.-% residual oxygen which have been achieved (4 vol.-% measured values) shows, that the plant is very gas-tight and ideal *Oxyfuel* conditions can be set and achieved.

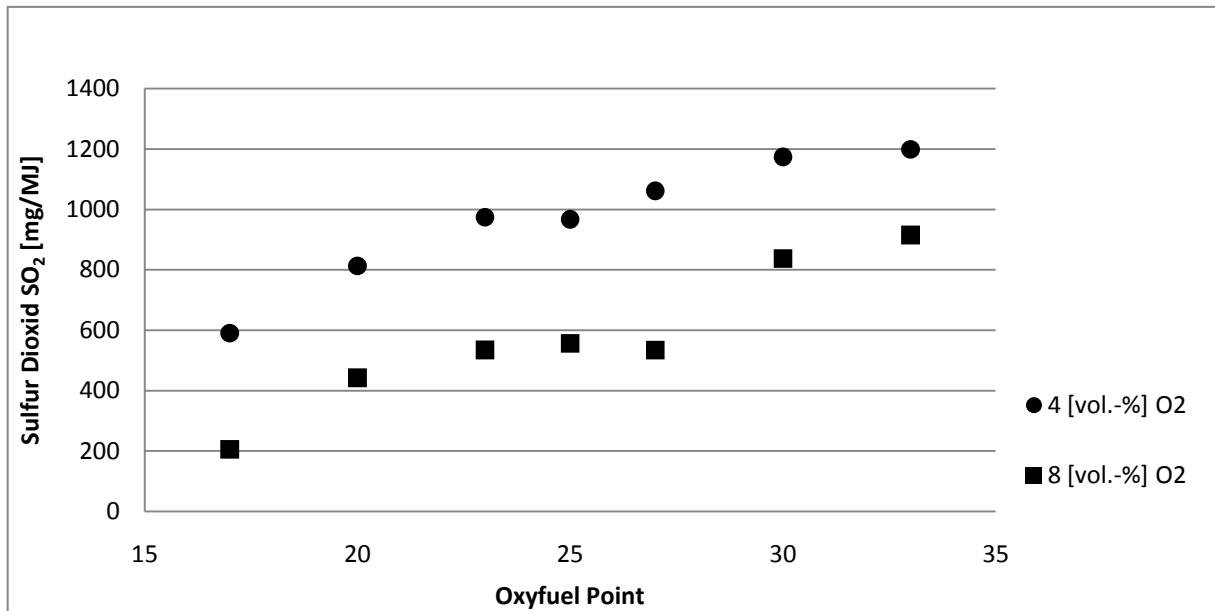

Figure 4: Concentration of SO₂ in the *Oxyfuel* flue gas stream dependent on the *Oxyfuel* point

The concentrations of SO₂ in the flue gas show two major effects on the same tests (Figure 4). First, at 4 % in contrast to the comparable points from 8 % residual oxygen in dry flue gas at the end of the combustion chamber, higher adiabatic reaction temperatures are reached, which is why in the 4 % case emissions of SO₂ are generally higher. The second effect is the variation of the recirculation rate. In the *Oxyfuel* points 17 to 20 significantly more flue gas is recirculated than in the *Oxyfuel* 30 to 33 cases, and thus at lower *Oxyfuel* points the adiabatic reaction temperature decreases. The result is a high SO₂ reduction potential between *Oxyfuel* 17 and *Oxyfuel* 33 for the same residual oxygen at the end of the combustion chamber.

The air-inleakage into the system has a dilution effect for the other gas components. In Figure 5, two cases with the same residual oxygen concentration in the dry flue gas are shown. The first case without leak air (FL) and the second case with 4 vol.-% leak air, as measured by the combustion chamber total throughput. If the real measured values are plotted in the diagram, it shows again the dependence of SO₂ formation on the adiabatic reaction temperature.

Furthermore, the dilution effect of atmospheric nitrogen from the inleaked air can be identified, so generally lower SO₂ concentrations are achieved.

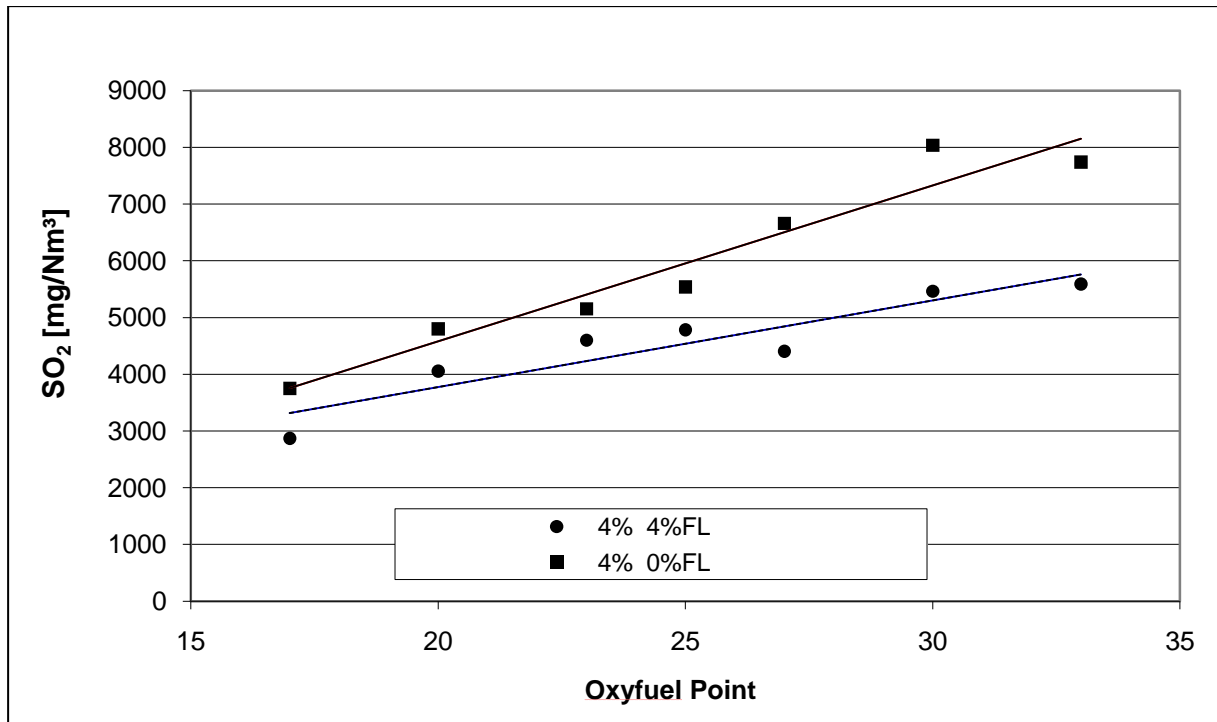

Figure 5: Influence of air-inleakage on the SO₂ concentration dependent on the Oxyfuel point

The impact of leak air was also investigated for nitrogen compounds. *Oxyfuel* operation in contrast to an air comparable case recirculates a large amount of flue gas. It therefore means that in recirculated flue gas at the entrance of the combustion chamber NO already exists and hence with increasing oxygen concentration more NO₂ is formed. As for the air comparable case, initially NO is formed. The remaining residence time is relatively short and the available oxygen concentration is clearly lower than the one at the combustion chamber entrance for *Oxyfuel* settings.

Figure 6 shows the comparison of NO formation in the *Oxyfuel* process with and without inleakage air (4 vol.-% from combustion chamber flow rate) and the air comparable case. From these results two statements can be made:

- the lower the in-leakage air, the lower is the nitrogen oxide formation and
- the higher the flue gas recirculation, the more intensified is reduction of NO formation.

In the *Oxyfuel* process, it is therefore possible to have a clear reduction in the nitrogen oxide emissions at defined boundary conditions. A lower inleakage of air implies therefore higher standard requirements for the plant construction and thus also higher manufacturing costs. The more gas is recirculated, the bigger the flue gas ducts and ventilator dimensions have to be. Therefore at this point there exists a limit, which is determined by the economic marginal value and the total energetic efficiency.

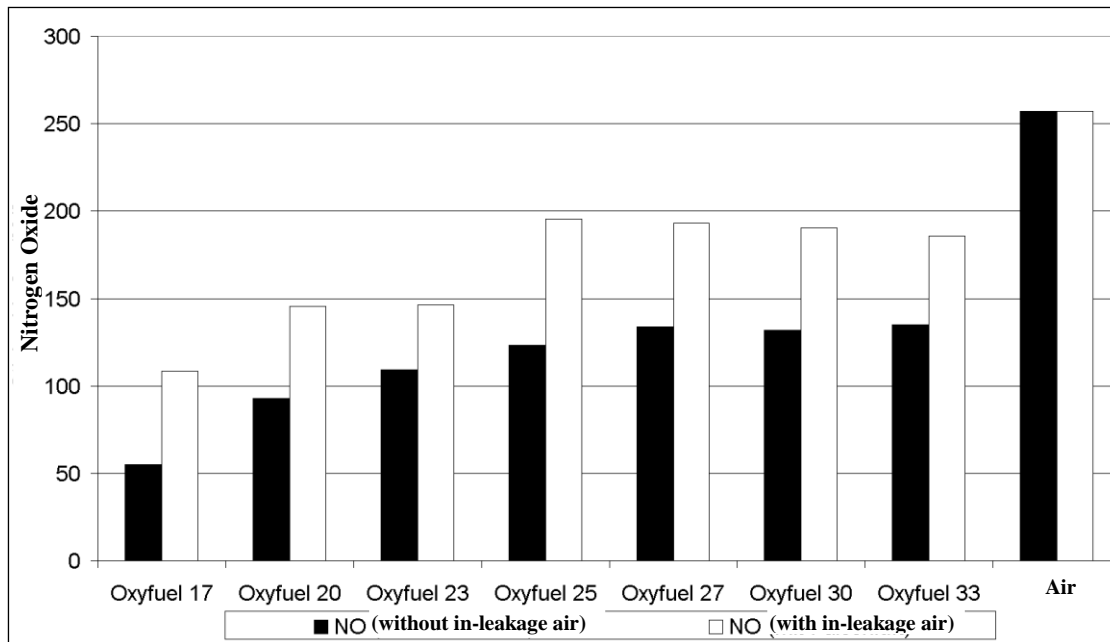

Figure 6: Comparison of the NO formation for *Oxyfuel* ideal, real and air comparable case with variable recirculation rate

For further investigations into the *Oxyfuel* process, a series of experiments with a single flame were carried out in the combustion chamber of the pulverized coal combustion test facility [2]. From the sampling of particles along the combustion chamber at different radial positions and the subsequent elementary analysis, the reaction progress and the nitrogen release from coal can be evaluated. Parallel to that, emission measurements at the same sampling positions were carried out. The conversion rate NO/NO_{max} indicates the mass ratio of the actual formed NO to the NO_{max} which could be formed and that is when all the existing nitrogen is converted into NO. As expected, the high temperatures at the combustion chamber for the *Oxyfuel* compared to air operation case are the reason for the rapid release of the fuel nitrogen. For both cases, after 200 mm approx. 97 - 98% of the fuel nitrogen is released. The conversion rate of NO/NO_{max} in the air operated case is higher than for the *Oxyfuel* ideal case. One reason to presume is the propagated NO reduction through the intensified flue gas recirculation from approximately 71 vol.-% in the *Oxyfuel* ideal case. The influence of the thermal NO formation for the air comparison case plays a secondary role for a flame temperature of approximately 1,200 °C at the close-up range of the burner. The pictures in Figures 7 – 9 show the concentration distribution of oxygen (O_2), nitrogen monoxide (NO) and nitrogen dioxide (NO_2) in the combustion chamber as examples for the *Oxyfuel 25* case (ideal) with residual oxygen content of 4 vol.-% (moist).

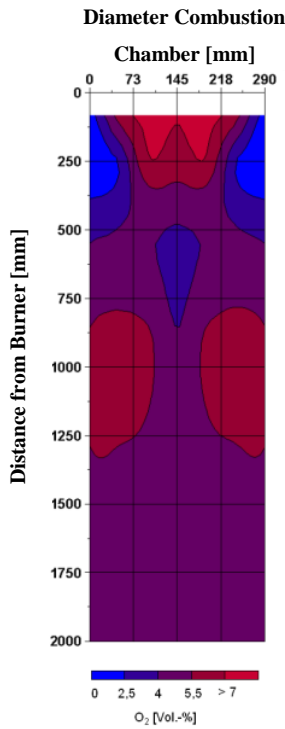

Figure 7: Measurement of O₂ in the combustion chamber (*Oxyfuel* 25)

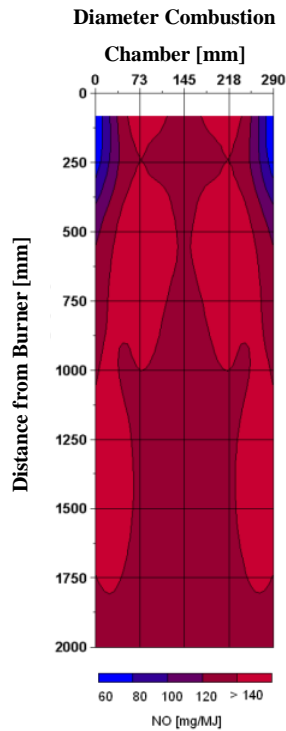

Figure 8: Measurement of NO in the combustion chamber (*Oxyfuel* 25)

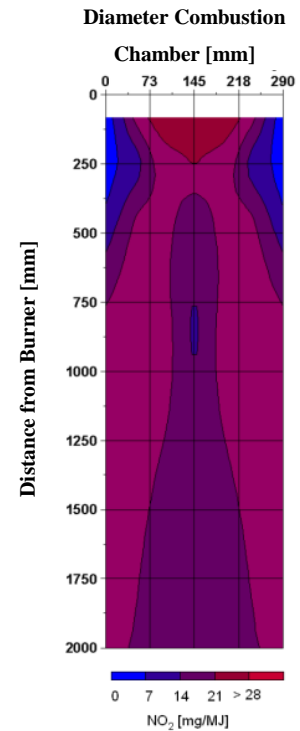

Figure 9: Measurement of NO₂ in the combustion chamber (*Oxyfuel* 25)

What can be noticed is the dependency of the NO formation from the oxygen supply particularly direct at the close-up burner range of the combustion zone. As earlier mentioned, the NO and NO₂ formations in under stoichiometric zones are strongly inhibited and thus respectively a reduction of N₂ can occur. In the zone directly at the burner head, where the partial oxygen pressure is at its highest, exists as mentioned a relatively high NO₂ concentration. The absolute concentration of the NO₂ alongside the combustion chamber remains constant and merely the distribution changes due to the fluid flow behaviour.

For ash-crust behaviour in the *Oxyfuel* process uncooled ceramic specimen holders are installed at the end of the combustion chamber. For all tests an identical residual oxygen content of 4 vol.-% (moist) at the end of the combustion chamber are set up. Compared to conventional combustion in the *Oxyfuel* process the recirculation varies from high (*Oxyfuel* 20) to little (*Oxyfuel* 30) volume flow rate.



	<p><i>Conventional combustion – 4 vol.-% residual oxygen</i></p> <ul style="list-style-type: none"> - Loose overlay of the ash - No slagging <p>Ash melting point: $T_S = 1099 \text{ }^\circ\text{C}$</p>
	<p><i>Oxyfuel 20 – 4 vol.-% residual oxygen</i></p> <ul style="list-style-type: none"> - Loose overlay of the ash - No slagging <p>$T_S = 1074 \text{ }^\circ\text{C}$</p>
	<p><i>Oxyfuel 25 – 4 vol.-% residual oxygen</i></p> <ul style="list-style-type: none"> - Loose overlay of the ash - Light slagging on certain points <p>$T_S = 1173 \text{ }^\circ\text{C}$</p>
	<p><i>Oxyfuel 30 – 4 vol.-% residual oxygen</i></p> <ul style="list-style-type: none"> - Complete slagging - No loose fraction <p>$T_S = 1280 \text{ }^\circ\text{C}$</p>

Figure 10: Ash-crust behaviour in an oxyfuel atmosphere by combustion of lignite

The experiments shown in Figure 10 that in comparison to the conventional combustion in the *Oxyfuel* process the slagging grade increases with decreasing recirculation volume flow. Since in *Oxyfuel 30* less is recirculated the combustion temperature increases. Therefore, a specimen

holder, which is installed at the same position as at the conventional mode of operation, completely slags. Although the ash melting temperature (T_S) from *Oxyfuel* 20 to *Oxyfuel* 30 increases because of mineral losses due to reactions with the gas phase, the outlet temperature from the combustion chamber increases even more, which leads to slagging on the uncooled specimen holder. For *Oxyfuel* 20, where the operation mode is similar to the conventional combustion, no major changes are to expect and the ash melting point is therefore at a similar temperature level. Because of the higher slagging grade, for the *Oxyfuel* points with reduced recirculation volume flow it thus needs to take constructive changes into account [3].

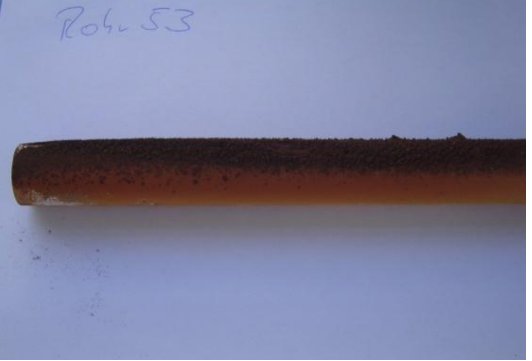
4 Flue Gas Treatment

There are a number of storage options for carbon dioxide that are currently investigated and which will not affect the climate. The future locations, but also the transport, make certain demands on the purity of CO_2 . It is therefore necessary to carry out various cleaning steps before. Several test rigs for the separation of water, SO_x , O_2 , N_2 and NO_x were therefore developed at the Universities of Technology Dresden and Hamburg-Harburg. The operating mode and the associated studies are briefly presented in the following.

For plant component design and better understanding of the process with a different gas composition in comparison to combustion with air phase equilibrium studies were performed with the help of a visual cell at the University of Technology Hamburg-Harburg at the Institute of Thermal and Separation Processes, chair of Heat and Mass Transfer. With the experimental CO_2 liquefaction installation it is possible to determine the interaction between the individual process components. Especially the kinetics of the water condensation and cryogenic CO_2 separation can be studied. The following binary and ternary phase equilibria were investigated: CO_2 -Ar, CO_2 - N_2 - O_2 .

To investigate the real behaviour and kinetics of the CO_2 liquefaction process, a CO_2 separation test rig has been built at the Institute of Energy Systems at the University of Technology Hamburg-Harburg. The chemical composition of the water condensate at various pressure and temperature levels in the process has been investigated. This allows a comparison of the water solubility, for instance SO_2 , as given in the literature with an industrially realistic condensation process. Moreover, it is possible to study the behaviour of the silica gel for gas drying under the influence of real *Oxyfuel* exhaust gas conditions. After the liquefaction of the CO_2 both stream phases above have been sampled and analysed through chromatography. This yields the exact stream compositions, which from the previous

equilibrium studies could be estimated only approximately. Especially for the liquid phase this knowledge is of particular importance, as this stream contains the CO_2 which afterwards will be stored through sequestration. For further particulars we refer you to [4].



Figure 11: Wet Flue Gas Desulphurisation Scrubber test facility

Since the sulfur fraction in lignite is generally higher than in hard coal, the focus of experimental studies on gas treatment at the University of Technology Dresden lies in the separation of sulfur dioxide. To do that a Wet Flue Gas Desulphurisation (wet FGD) Scrubber test facility (Figure 11) was built and is connected to the downstream side of the pulverised fuel combustion test facility. Therefore a direct comparison for the desulphurisation behaviour in air or *Oxyfuel* mode is given.

The scrubber is operating as spray absorber as well as bulk or package absorber respectively. Thus a double-row configuration but also a double-loop FGD is possible. The reaction step for oxidation (and forming gypsum) can be realised with internal or external oxidation. The latter is a special development for the *Oxyfuel* process and aims in particular to investigate the gas-tightness. Additional internal water condensation as well as cooling or heating of the absorbate in the absorber and the external oxidation can be investigated.

The studied parameters are L/G ratio (liquid to gas), pH value of the absorbent in the absorber tank; pH value of the absorbent, concentration of the absorptive, velocity of the flue gas, solid mass fraction in the absorber tank, solid mass fraction in the absorbent and the use of additives. For the analysis of the absorbate there are pH and redox probes available in the absorber tanks and the external oxidation. Samples of absorbate and absorbent, flue gas condensate as well as flue gas can be analysed regarding to their composition and degree of purity by the in-house lab of the chair.

In essence, with the experiments it could be shown that the achievable desulphurisation in the *Oxyfuel* process is not inferior compared to the combustion with air. The reason lies in poor chemical solubility of the carbon dioxide at a typically low pH of around 6, despite the much

higher concentration in the gas phase. For an arrangement of the FGD in the recirculation of the power plant no major changes are therefore necessary compared to the conventional FGD. In contrast, for an arrangement of the FGD in the exhaust stream before compression with a lower exhaust flow rate for *Oxyfuel* a constructive change through the higher SO_2 concentration is to be expected and subject to further studies on components for the *Oxyfuel* process. The external oxidation showed a sufficient gas density, so this simple, but energy-saving modification of the conventional procedure for an application in the power sector seems likely.

As an alternative to the conventional separation of sulphur dioxide process for SO_2 distillation was developed at University of Technology Dresden [5]. SO_2 is a very popular industry product that is normally produced artificially and in the *Oxyfuel* process it is formed as a by-product that then elaborately and with great use of auxiliary substances is bound and often be land filled due to the large volume. The compression of the exhaust gas at high pressures is normally uneconomical but here it allows the separation of SO_2 at low additional energy which can largely be met through rejected heat.



Figure 12: Rectification Column test facility



Figure 13: Liquefaction Route test facility

To distil the exhaust gas it first has to be liquefied. This is done in a specially developed liquefaction route (Figure 13), which consists of a membrane module for water separation, a

compressor, a heat exchanger for condensation, a phase separator and a condensate pump. The liquefied exhaust gas stream is then pumped in the Rectification Column (counter current distillation) test facility (Figure 12) which was also purpose-built for the *Oxyfuel* process and has an integrated evaporator and a condenser for separation of SO₂ and if necessary, further gaseous impurities of the *Oxyfuel* flue gas.

The exhaust gas can be liquefied continuously for direct use in the rectification column or in batch operation mode and is then stored in a gas cylinder stock. Feeding and product extraction on every bubble tray of the rectification column is possible. The overhead product can be analysed with regard to the composition and degree of purity by gas analysis measurement.

The experiments already performed showed that liquefaction up to a pressure of 60 bar is possible by setting the respective condensation temperature. The resulting condensate consists mainly of CO₂ and SO₂. During the experiments carried out with a special gas mixture, consisting of CO₂ and SO₂, removed from a gas cylinder the purities predicted by phase equilibrium considerations were observed. Unfortunately the results of the distillation of real flue gas could not be evaluated until the submission date for this paper. With the results achieved by now, we are confident to reach our desired goal, the separation of SO₂ from the flue gas stream under minimal use of additional energy.

5 About the ADECOS II Research Project

The climate change as a pan-societal concern in this context requires new approaches, since the sole efficiency increase of power plants are not long term enough to allow the carbon dioxide emissions to be significantly reduced. Thereby the *Oxyfuel* coal-fired power plant is a possible and promising technology.

The collaborative research project was initially planned for a three year term. It was financed by the German Federal Ministry for Economic Affairs and Labor (BMWi) and the participating industrial companies with the aim to provide the technical conditions for the world's first pilot plant with a capacity of 30 MW and for future large-scale power plants. ADECOS (Advanced Development of the Coal-fired Oxyfuel Process with CO₂ Separation) connects the six industrial companies *Vattenfall Europe Generation (Cottbus)*, *RWE Power (Essen)*, *E. ON Energie (Munich)*, *Alstom Power Boiler (Stuttgart)*, *Babcock Hitachi Europe (Oberhausen)*, *Siemens Power Generation (Erlangen)* with the three universities University of Technology Dresden, University of Technology Dresden Hamburg-Harburg and Zittau-

Gorlitz. The coordination of the joint research project is carried out by the University of Technology Dresden.

The kick-off meeting took place at the University of Technology Hamburg-Harburg on June 2nd 2005. At this time the resident Institute of Energy Systems had already officially started to work on the project since October 2004. On November 30th 2006 the 3rd project meeting was held in Dresden with a review of the activities during the past one and a half years and the roadmap for ADECOS Phase II was presented to the partners. With a now more special focus on basic research activities such as *Oxyfuel* coal combustion, CO₂ cleaning processes and overall system evaluation the new project ADECOS II started.

Now, two and a half years later, the project ADECOS II is successfully completed and the basics for the construction of the pilot plant, but also for the design of a large-scale power plant have been created. The working group is now going to focus on more detailed questions on individual components and to the further investigation of the *Oxyfuel* process with circulating fluidised bed, as a promising solution for the implemented type of steam generator.

For more information about the available test facilities, the current status and future research projects on the coal-fired *Oxyfuel* process, please visit www.adecos.de

6 References

- [1] Weigl, S. **Mathematische Modellierung und experimentelle Untersuchungen zum Oxyfuel-Prozess an einer 50 kW Versuchsstaubfeuerung.** Dresden : s.n., 2009. *Dissertation.*
- [2] Wilhelm, R., Weigl, S. and Beckmann, M. **The Comparison of a convectional TBK-Combustion to Oxyfuel TBK Combustion based on investigations into Nitrogen Oxide (NO) formation and respectively the reduction reactions in a 50 kW Pulverized Coal Combustion Test Facility.** Dresden : s.n., 2009.
- [3] Beckmann, M., et al. **Abschlussbericht - ADECOS II - Advanced Development of the Coal-Fired Oxyfuel Process with CO₂ Separation.** Dresden : s.n., 2009.
- [4] Köpke, D., et al. **Liquefaction of Oxyfuel Flue Gas - Experimental Results.** 2008.
- [5] Löser, J. and Klemm, M. **Innovative Verfahren der Entschwefelung zur Erzeugung reinen Kohlendioxides aus dem Abgas einer Sauerstoffverbrennung von Braunkohle für CO₂-freie Kraftwerke nach dem Oxyfuel-Prozess.** Dresden : s.n., 2008.