

FLUIDIZATION2000

Science and Technology

Conference Papers
Seventh China-Japan Symposium

October 20-22, 2000

Xi'an University of Architecture & Technology

Xi'an P. R. China

Editors

Delong Xu

Shigekatsu Mori

Organized by
Chinese Society of Particuology
The Society of Chemical Engineering, Japan

Xi'an Publishing House

Author: Delong Xu Shigekatsu Mori

Publication: Xi'an Publishing House

Address: No.34 North Chang'an Road, Xi'an 710061, China

Tel: +86 29 5253740

Printing House: Xi'an Univ. of Arch. & Tech. Printing Factory

Edition: 850×1168 1/16

Print Plate: 27.75

Words: 780,000

Amount: 1-400

All rights reserved. No part of this publication may be reproduced, stored in a retrieval system, or transmitted in any form or by any means, electronic, mechanical, photocopying, recording or otherwise, without the prior written permission of the copyright owner.

First published Sept. 2000

ISBN 7-80594-692-2/T· 20

ENERGY UTILISATION OF BIOMASS FROM THE SUGAR INDUSTRY WITH FLUIDIZED BED AND GRATE SYSTEMS

Beckmann, M. ¹⁾; Schulenburg, F. ²⁾; Scholz, R. ²⁾;

ABSTRACT

In the production of sugar, by-products such as pulp material arise. The pulp material is dried with process steam to about 70 % to 10 % water content. At present the pulp material can be sold as feed for agriculture. Due to continuous decrease in selling prices the energetic utilisation of pulp material as substitute fossil fuels for process steam generation have been discussed recently. A reduction of climatic relevant CO₂ could be achieved simultaneously. In the here presented paper different process concepts and their realisation possibilities are discussed. The evaluation includes the energy conversion in power stations as well as possible drying processes. Finally, results from investigations at pilot scale grate systems (forward- and reverse-acting) and a fluidized bed reactor for combustion and a gasification mode using pulp material are presented.

2 KEYWORDS

Biomass, sugar industry, drying process, energy utilisation, fluidized bed reactor, grate systems, research plant.

3 INTRODUCTION

For the production of sugar from sugar beets, process steam is required. The steam is usually generated through classical combustion of coal at grate furnaces with boilers. These so-called combustion –post-combustion processes can be used for the combustion of biomass fuel such as pulp material. If a new plant for energy conversion is considered, gasification-post combustion processes with gasification at grate systems or in fluidized bed reactors could also be envisaged [1-4].

This gasification-post combustion concept in grate systems, currently examined on a test-size scale, appears promising, as, in comparison to the conventional incineration processing,

- the flue gas mass flows are significantly reduced,
- combustible gases which enable an independent post-combustion process are generated,

¹⁾ Prof. Dr.-Ing. Michael Beckmann, Bauhaus-Universität Weimar, Germany.

²⁾ Dr.-Ing. Frank Schulenburg, Prof. Dr.-Ing. Reinhard Scholz, Technische Universität Clausthal, Germany.

- the post-combustion process itself can be optimised regardless of the process on the grate with the help of familiar primary measures for reducing the NO_x-emissions and at the same time achieving high burn-out results,
- emission loads can be reduced considerably.

Due to the size and the homogeneity of the pulp material fluidized bed reactor systems also seem to be well-suited.

However, several practical tests are necessary before one of the concepts can finally be evaluated. A row of questions concerning the optimal water content, ignition behaviour, slagging tendency, fouling behaviour and emissions occur. Keeping that in mind, the evaluation is carried out two-fold. First of all, the concepts are calculated theoretically. In the second part, results obtained from pilot scale tests on grate systems and in fluidized bed are discussed.

4 THEORETICAL POTENTIAL OF THE PROCESS CONCEPTS

First of all the energetic potential of different process concepts should be regarded. Therefore, different possibilities for the energy conversion in power stations and for the drying process are envisaged independent of the respective apparatus system. The balancing methods used including calculation of different efficiencies etc. are already described in other papers [5-7].

Fig. 1a and 1b show the balance schemes which could serve as energy utilisation concepts in the sugar industry.

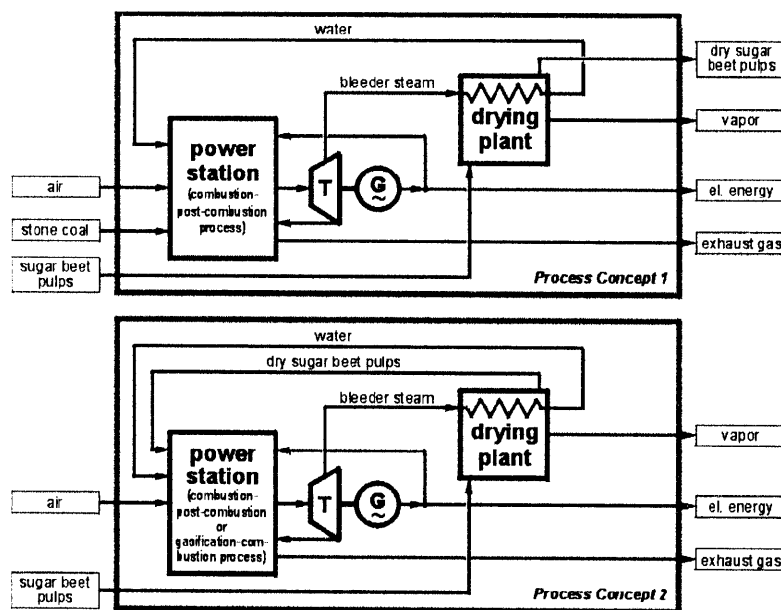

Figure 1a: Block flow diagrams for different energy utilisations of biomass in sugar industry (Concept 1 and 2).

Process Concept 1: The scheme corresponds to the present situation in the sugar industry. In a power station, fossil fuels are converted, process steam and electrical energy are generated and the bleeder steam is used for drying pulp material (feed).

Process Concept 2: In contrast to Concept 1, the dried pulp material substitutes the coal completely. Combustion as well as gasification mode for solid conversion (first unit) followed by post-combustion (second unit) is envisaged.

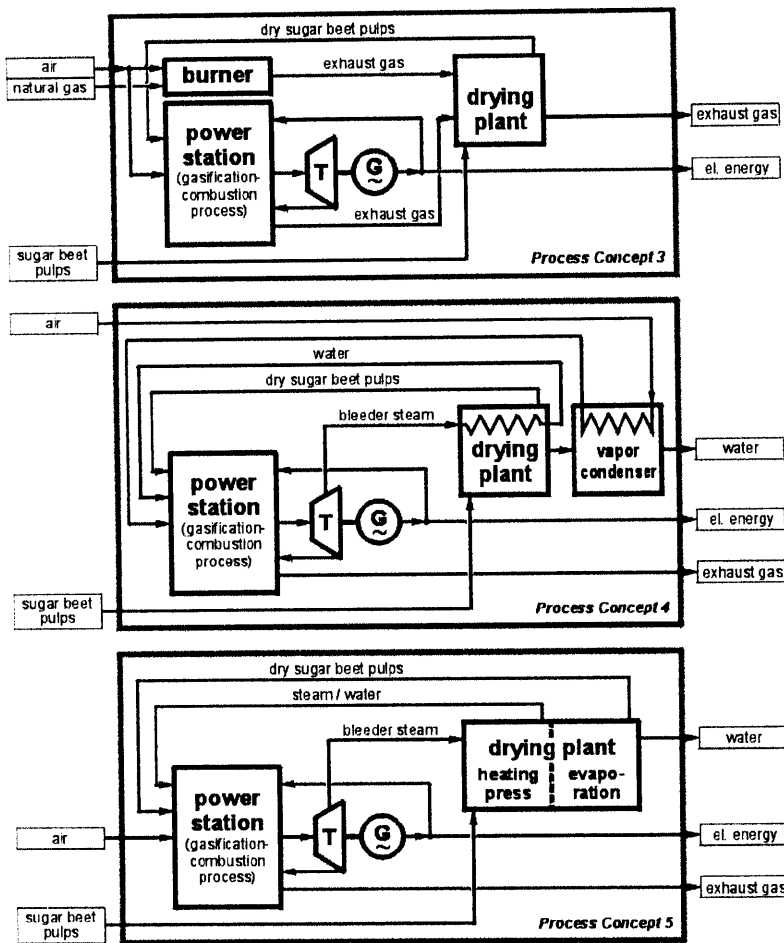

Figure 1b: Block flow diagrams for different energy utilizations of biomass in sugar industry (Concept 3, 4 and 5).

Steam condenses at the surface of the pulp material which mobilises the cell water. The water can then be separated by pressing. Finally a reevaporation of the pulp material follows.

With the balancing methods and mathematical models described in detail in [5] the different process concepts of the power station can be evaluated theoretically (Fig. 2). Fig. 2 depicts that for dried pulp material temperatures of 950 °C could be achieved without additional fuel for air ratios of $\lambda = 1,6$. For pulp material with higher water content either additional fuel (natural gas; $EV = \text{enthalpy of n.g.} / \text{energy of fuel}$), oxygen enrichment ($\psi_{O_2,air}$ -variation) and / or reduction of the air ratio (variation of λ) is necessary. The comparison of the net primary efficiency (ordinate in Fig. 2) and of the specific flue gas amount leads to the expected conclusion that the gasification–post-combustion concept is the best.

Process Concept 3: For the power station process now a gasification- post-combustion process is considered. The waste heat from power generation is used for drying pulp material. Additional energy for drying is supplied by a natural gas burner system.

Process Concept 4: Concept 4 corresponds to Concept 2 except for the drying process. Here the condensation enthalpy of the exhaust vapours is used for the drying.

Process Concept 5: For the estimation of the theoretical maximum of energy utilisation of pulp material the drying energy is minimised. For the drying process a mechanical-thermal dewatering [8] is taken into consideration. Wet steam flows into a chamber filled with rough pulp material.

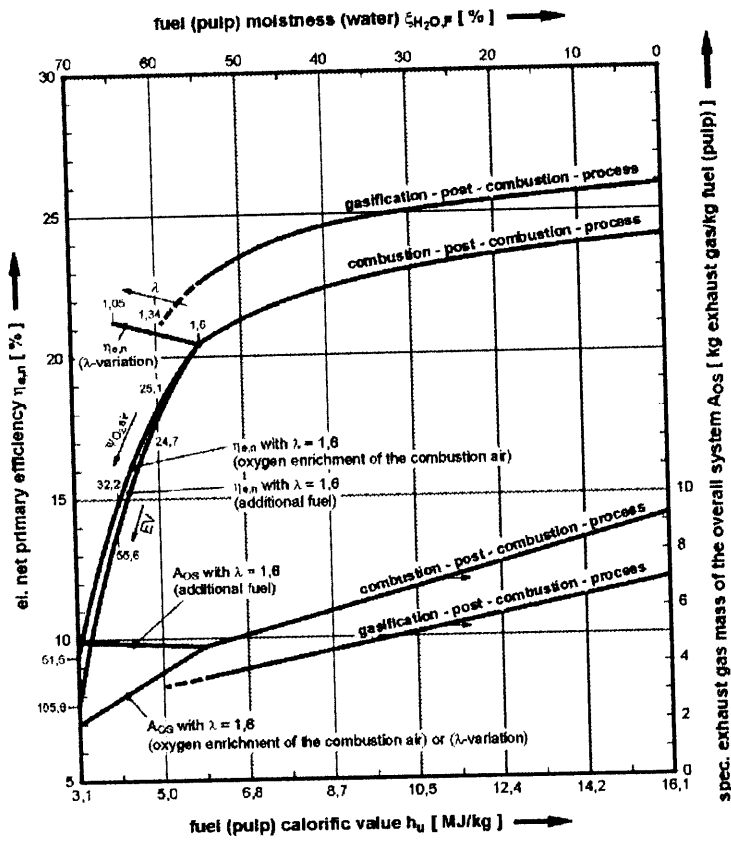

Figure 2: El. net primary efficiency $\eta_{e,n}$ and specific exhaust gas mass A_{OS} dependent upon the fuel (pulp) calorific value h_u and the fuel (pulp) moistness $\xi_{H_2O,F}$ for gasification-post-combustion – processes and combustion-post-combustion – processes by a min. temperature $\vartheta_{min} = 950^\circ C$.

For the following overall comparison the basis for each Concept (Fig.1) is 1000 MJ of fuel energy. Fig. 3 shows the comparison of the specific electrical energy, the specific flue gas amount, and the CO₂ emissions. Summarising the results one can conclude: The concepts 2a, 2b, 4 and 5 burden the environment with only neutral or regenerative CO₂. Using gasification- post-combustion processing the flue gas amount can be reduced remarkably. The conventional drying process can be improved regarding the energy efficiency considerably. To the last point it should be mentioned that the calculations are carried out on the basis of simplified assumptions (e.g. without internal consumption of electrical energy for the drying process) to show the

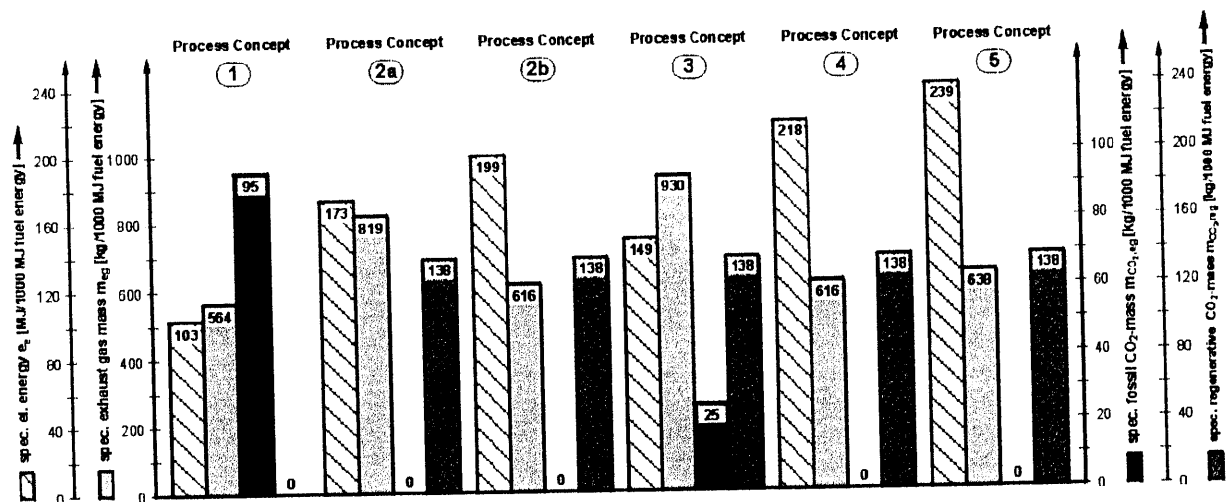

Figure 3: Comparison of the different process concepts (see Figure 1 and text). theoretical potential.

5 PILOT PLANTS

5.1 FORWARD-ACTING GRATE WITH SEPARATED POST-COMBUSTION PROCESS

With special emphasis on the examination of primary measures regarding the conversion of solid material in grate systems, a pilot plant was erected –in accordance with the demands on the process operation– with a clear distinction of the sub-steps in mind:

- conversion of solid matter on the grate,
- post-combustion of the gases thereby generated and
- exchange of heat.

Fig. 4 shows the processing flow chart including the measuring and control set-up. The plant consists of the main components

- 3-zone-forward-acting grate system
- combustion chamber system (for the self-sustained and independent multi-staged combustion of gases generated in an understoichiometrical grate process and of the inevitable flue dust)
- heat exchanger and
- flue gas purification.

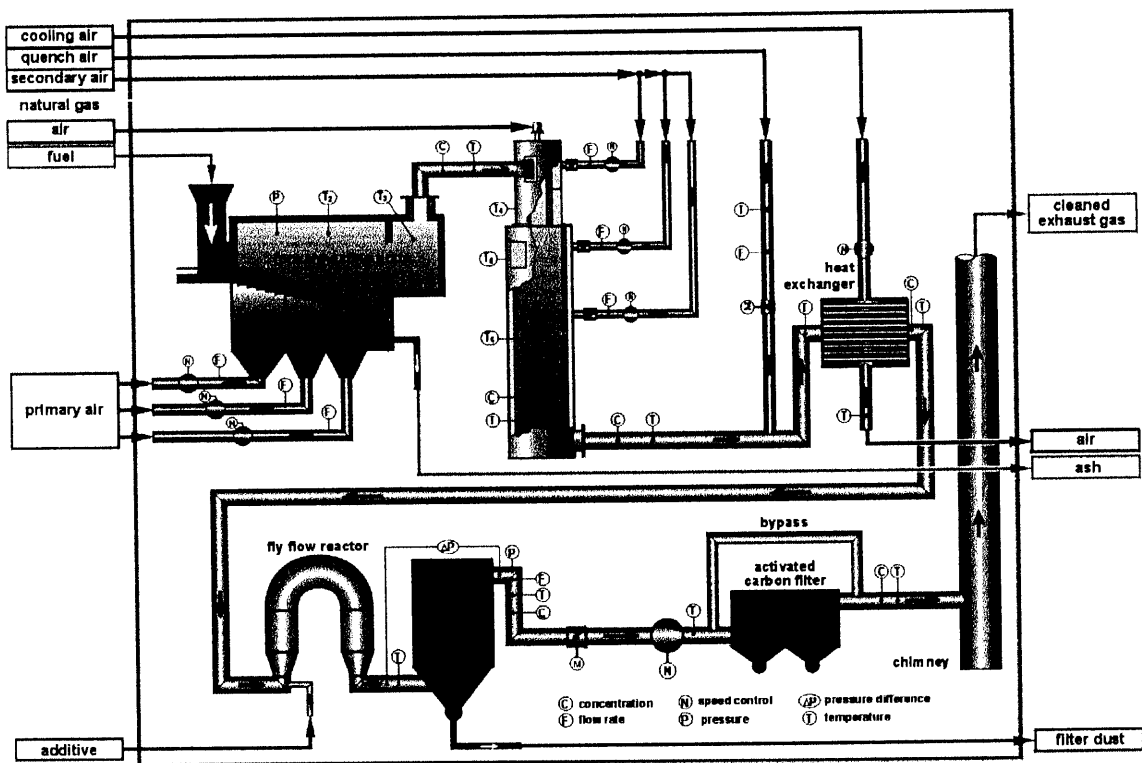

Figure 4: Flow chart of a forward-acting grate system (pilot plant) with post-combustion chamber and gas cleaning.

The solid combustible is transported via a conveyor belt to the storage hopper. A feeding ram situated at the lower end of the feeding hopper ensures the discontinuously charging of the first grate stage. The motion of the grate elements then ensures the transport of the combustible in the direction of the ash discharge. In all three grate zones the forward motion is independently adjustable. The reaction gas (usually air; however, re-circulation of a flue gas partial flow or enrichment of the air with oxygen or nitrogen is possible) enters the chamber beneath the grate and is also independently adjustable in the three grate zones with regard to mass flow and oxygen concentration.

When operating the grate process understoichiometrically, a combustible gas is generated in the grate stage, which, along with the inevitable flue dust from the grate plant, is directed into a combustion chamber system for the self-sustained, independent, multi-staged incineration. In the case of an overstoichiometrical operation of the grate, the flue gas merely passes through the combustion chamber without undergoing post-combustion.

The operational settings in the pilot plant can be regulated, among other things by the following parameters: input composition of the combustible, residence time, air ratio λ , oxygen enrichment of the reaction gas, simulation of flue gas recycling by nitrogen supply, variation of the loading condition and variation of the air distribution. The conditions of the pilot plant with a thermal power of 0.5 MW allow a transfer of the obtained test results to industrial-scale plants.

5.2 REVERSE-ACTING GRATE WITH INDEPENDENT POST-COMBUSTION

In the context of the forward-acting grate a further plant concept was incorporated – a reverse-acting grate. In comparison with the forward-acting grate, the reverse-acting grate is equipped with five separate under-grate blast zones (Fig. 5). Compared with the forward-acting grate, the reverse-acting grate has a greater inclination in the direction of the discharge. In the opposite direction the individual grate bars lie on top of each other in an imbricated style. The reverse motion of the grate elements counter the downward motion of the solid caused by gravity through the inclination, thus resulting in a thorough mixing of the combustible [1].

Corresponding connection pipe-pieces are available for counterflow, main stream and parallel flow by which the influence of the flow and residence time conditions in the combustion chamber can be examined. The thermal power is at the same range (0.5 MW) as the forward-acting grate. As explained for the forward-acting grate the operating conditions in the pilot plant can in this case also be varied if desired.

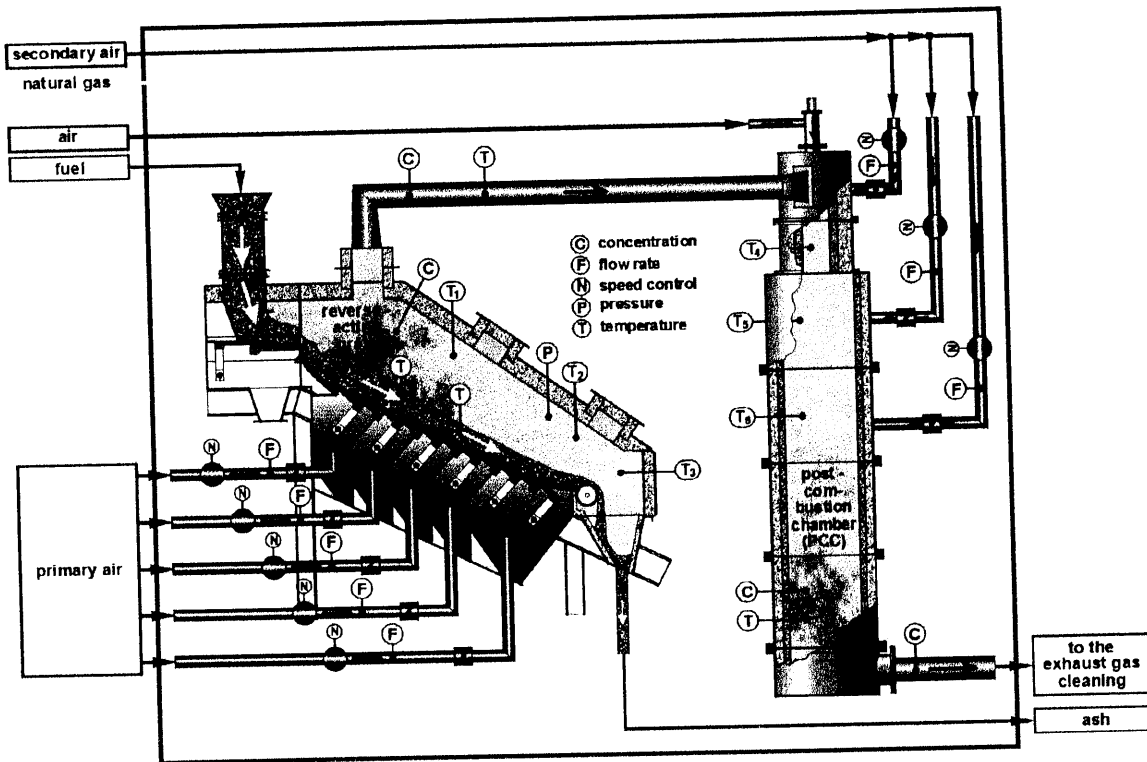

Figure 5: Flow chart of the reverse-acting grate system with a post-combustion chamber.

5.3 FLUIDIZED BED REACTOR

With regard to examination of gasification and incineration, predominantly of agricultural waste and biomass, a fluidized bed reactor which can be operated both in circulation and steady-state mode on a pilot plant scale is installed. The processing flow chart is presented in Fig. 6. The fluidized bed reactor consists of the main components

- fluidized bed, comprised of
 - ◆ fluidized bed and
 - ◆ free board,
- hot gas cyclone,
- post-combustion chamber system and
- flue gas purification.

The fuel is supplied via a conveyor worm from the charging bunker to about 300 mm above the bottom of the fluidized bed. A maximum mass flow of about 30 kg/h can be attained. The maximum fluidized bed height in a steady-state mode can reach approx 300 mm.

The heating of the fluidized bed is achieved with a natural gas burner. Depending on the chosen parameters, load ratio and primary air ratio, secondary air can be supplied via 4 radially connected inlets above the fluidized bed in order to optimise burn-out. The gas generated in the fluidized bed is fed to a succeeding hot gas cyclone where the dust and ash are removed. For the post-combustion of the gases a combustion chamber is post connected.

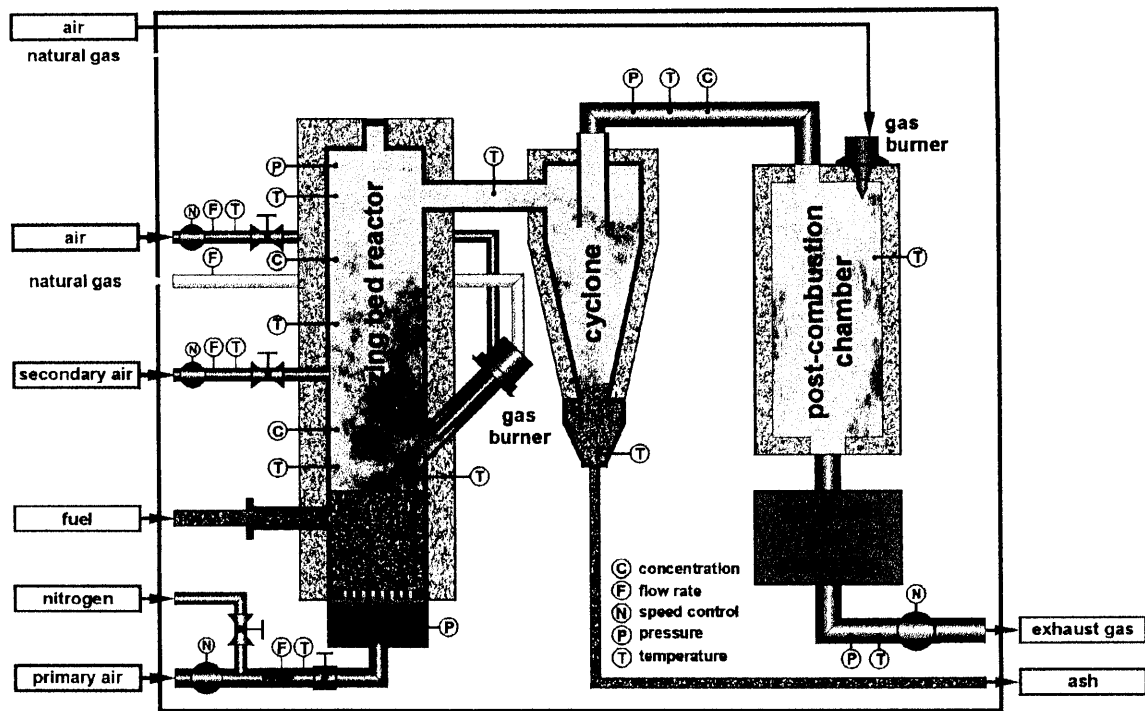

Figure 6: Flow chart of the fluidized bed reactor with post-combustion chamber.

The operating conditions in the pilot plant can be varied over the following parameters: composition of input material, residence time, air ratio λ , oxygen enrichment of the reaction gas, simulation of flue gas recycling by supply with nitrogen, variation of the load ratio, variation of the air distribution and optionally ash feedback.

6 RESULTS OF THE PILOT-SCALE TESTS

Tests lasting several days were carried out at the previously-mentioned test facilities. Fig. 7 summarises the important results of the combustion-post-combustion tests of both grate systems. A self-sustaining combustion of pulp was possible with $\lambda=1,5$ for water contents below 40 mass %. The loss on ignition of the remaining ash was below 1 mass %. The intensive stoking of the reverse-acting system in comparison with the forward-acting grate supports the ignition on the one hand; on the other hand, the slagging tendency was clearly larger.

apparatus	distribution of primary air	gas flow	fuel moistness	air ratio	post combustion chamber (PCC)		grate temperature			PCC temperature		
					ψ_{NO_x}	ψ_{CO}	ϑ_1	ϑ_2	ϑ_3	ϑ_4	ϑ_5	ϑ_6
	%		Ma.-%	1	mg/m ³ⁿ)	mg/m ³ⁿ)	°C	°C	°C	°C	°C	°C
reverse-acting grate	11/48/39/2/0	parallel flow	40,3	1,51	70	2	738	837	848	929	853	743
	33/34/33/0/0		38,2	1,58	129	24	572	317	206	987	891	773
	35/46/19/0/0	reverse flow	13,5	1,57	321	55	782	535	358	1121	1003	884
forward-acting grate	33/48/19	parallel flow	38,7	1,52	75	22	—	734	894	—	—	—
	35/45/20		11,4	1,83	168	1	—	794	921	—	—	—

Figure 7: Results of the combustion-post-combustion process (grate system and post-combustion chamber).

Lower temperatures in the furnace (over the grate) result for the counter-current flow. The drying is insufficiently supported by the back-flow of the gases. In comparison with co-current flow, this leads to a deteriorated burn-out of the gases and the ash.

The drying process can be supported by a high air supply into the first air zones of the grate. If possible flue gas recirculation can also be considered here.

Grate velocity of the forward-acting grate must be adjusted carefully. If the velocity is too high ignition front could be extinguished. A deterioration of the gaseous burn-out and the loss on ignition is the consequence, independent of the co-current flow.

The NO-emission lie considerably below 200 mg/m³ (i.s.s.dry , 11 vol. % O₂). The potential for further optimisation is not yet exhausted.

For all test series, strong slaggings with a high content of alkaline earths were ascertainable. The slaggings in the heat exchanger were particularly strong (temperature level from 500 °C to 180 °C).

The test results for the gasification–post-combustion mode at grate systems can be summarised as follows: The loss on ignition was not entirely sufficient. Here a corresponding optimisation potential exists.

The before-mentioned tendency of slagging at the grate particularly occurred for pulp material with low water content. Regarding the slagging of alkaline earth in the heat exchanger no improvement was detectable.

With the gas generated with the under-stoichiometrically operated grate a self-sustainable post-combustion process with a good burn-out was possible.

The overall air ratio and the exhaust gas amount could altogether be lowered with regard to the combustion mode of the grate. Same applies to the flue dust.

In the fluidized bed reactor, stable combustion as well as gasification conditions with the pulp material could be achieved (Fig. 8, last column). A limiting value for the stable ignition must be viewed in respect to the water value (content of water below 40 mass %)o. Slagging of the bed could be avoided.

apparatus	distribution of primary air	gas flow	fuel moistness	air ratio grate	air ratio overall	grate			post combustion chamber (PCC)		grate temperature			PCC temperature		
						ψ_{CO}	ψ_{CH_4}	ψ_{H_2}	ψ_{NO_x}	ψ_{CO}	θ_1	θ_2	θ_3	θ_4	θ_5	θ_6
—	%	—	Ma.-%	1	1	Vol.-%	Vol.-%	Vol.-%	mg/m ³ *)	mg/m ³ *)	°C	°C	°C	°C	°C	°C
reverse-acting grate	7/30/26/21/16	parallel flow	40,3	0,83	1,26	0,2	0,9	1,3	83	5	356	442	640	514	902	787
	10/25/28/19/20		18,4	0,71	1,39	10,1	1,7	3,2	217	5	489	771	849	940	1019	888
	6/28/24/19/23	reverse flow	41,0	0,89	1,27	6,2	1,3	2,3	261	1	609	729	643	796	918	781
	7/29/21/22/21		13,5	0,50	1,11	10,4	2,2	2,9	162	0	616	801	856	1077	1011	854
forward-acting grate	31/48/21	parallel flow	36,7	0,49	1,10	5,8	1,5	3,2	122	0	—	678	773	615	906	741
	40/30/30		11,4	0,87	1,16	5,3	0,7	3,1	134	0	—	944	1068	958	1064	964
fluidizing bed reactor	—	—	36,8	0,88	—	3,3	0,9	0,5	—	—	—	—	—	—	—	—

Figure 8: Results of the gasification-combustion process (grate system, post-combustion chamber and fluidized bed reactor).

Altogether the first results of the pilot-scale tests show that pulp material can be utilised for energy conversion under combustion as well as gasification mode in grate and fluidized bed reactors. In further test series the slagging problems (temperature adjustment) must be solved. Furthermore, consideration should be given to the economic aspects.

7 REFERENCE

- [1] Beckmann, M.; Scholz, R.: Vergasung von Abfällen in Rostsystemen; In: Vergasungsverfahren für die Entsorgung von Abfällen, Born, M., Berghoff, R. (Hrsg.), Springer-VDI-Verlag GmbH, Düsseldorf, 1998, S. 80-109.
- [2] Beckmann, M.; Scholz, R.; Wiese, C.; Busch, M.; Pepler, E.: Gasification of waste materials in grate systems; 4th European Conference on Industrial Furnaces and Boilers, Porto, Portugal, 1.-4. April 1997, Proceedings.
- [3] Beckmann, M.; Scholz, R.: Simplified mathematical model of the combustion in stoker systems; 3rd European Conference on Industrial Furnaces and Boilers, 18.-21., April 1995, Lisbon, Portugal, Proceedings, Vol. 2, S. 61-70
- [4] Scholz, R.; Beckmann, M.; Schulenburg, F.: Experimental research on gasification of coarse waste on a stocker system and separate after burning as well as optimization with the aid of a process model; The 1994 Incineration Conference, May 9-13, Houston, Texas, USA, Proceedings by University of California, Irvine, S. 297-306.
- [5] Schulenburg, F.: Energetische Bewertung thermischer Abfallbehandlungsanlagen unter Berücksichtigung verschiedener Prozeßführungen; Dissertation an der Technischen Universität, 1999.
- [6] Schulenburg, F.; Scholz, R.: Bilanzierung und Bewertung thermischer Abfallbehandlungsverfahren; Einfluß unterschiedlicher Abfallvorbehandlungsverfahren. VDI-Berichte 1387, VDI Verlag GmbH, Düsseldorf 1998, S. 17-47, ISBN 3-18-091387-8.
- [7] Scholz, R.; Beckmann, M.; Schulenburg, F.; Brinker, W.: Thermische Rückstandsbehandlungsverfahren Aufteilung in Bausteine und Möglichkeiten der Bilanzierung; Brennstoff-Wärme-Kraft (BWK) 46 (1994) Nr. 11/12, S. 469-482.
- [8] Kallmeyer, D.; Wick, W.: Entwicklungsschritte zum trockenbraunkohlebefeuerten Kraftwerk; VGB Kraftwerkstechnik 77 (1997), Heft 4, S. 300-303.

8 NOMENCLATURE

SYMBOLS

A	specific exhaust gas mass
c	energy
EV	energy ratio
h	specific enthalpic
m	mass
θ	temperature
λ	air ratio
η	efficiency
ξ	concentration (mass related)
ψ	concentration (volume related)

INDICES

air	air
e	electric
eg	exhaust gas
F	fuel
g	grate
min	minimum
n	net
OS	overall system
reg	regenerative
u	calorific value